

MOTOFIT

Force Control Assembly Tool

HIGH-SPEED FORCE SENSING PACKAGE

KEY BENEFITS

High tolerance assembly
Built-in programming tools
Improved reliability

COMPONENTS

Six-axis sensor (200 N (V) or 1,000 N (H or V))
High-speed communication board
Power supply box
Robot-specific mounting flange adapter
Engineering Support Tool software with interface panel software

CONTROLLERS

DX200 FS100 MLX200

- MotoFit alters the robot's position based on the force encountered to align or assemble parts. (During normal robot operation, robot is setup for positional control; the robot moves to or retains position even when external forces are applied, provided that forces do not exceed limits that would cause an error.)
- Six-axis force sensor detects three translational forces and three axial moments to detect external forces during job execution.
- Three operations (touching, fitting and inserting) are combined to provide automatic precision fits of mating surfaces of 10-100 μm .
- High-speed fits - up to 20 mm deep with h7/H7 tolerance - can typically be done in five seconds.
- Force sensing control parameters can be taught quickly without unique skills.
- Hole position detection and snag prevention increase reliability.
- The Engineering Support Tool (EST), a PC application, is used for sensor setup and job creation. It supports one or two robots, up to 24 force files, and robot or tool coordinate systems. Jobs can be edited on the controller if needed.
EST features:
 - Ability to enable or disable each translational force or axial moment
 - Helpful graphics for troubleshooting and setup
 - Step-by-step instructions
- Ideal for precision part assembly applications including drive train components, seats, electronics, battery assembly and non-destructive testing.

MOTOFIT

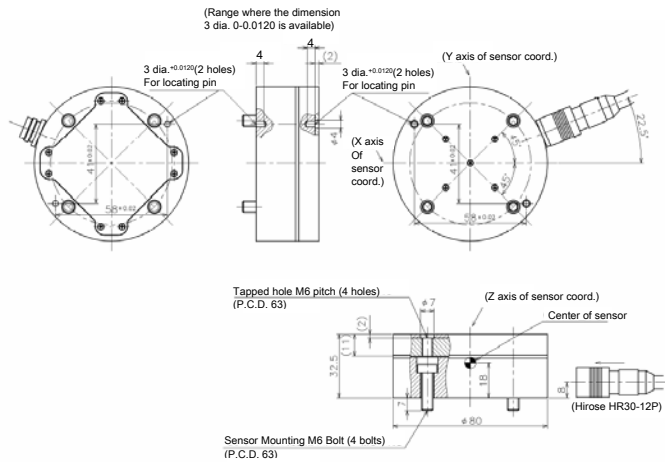

200N Sensor

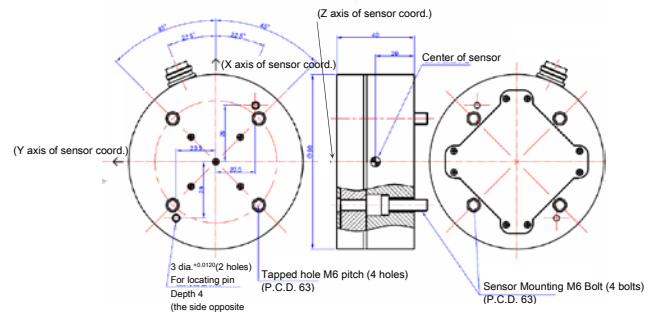

1000N Sensor

SPECIFICATIONS

Operation Functions	Touching function (dedicated INFORM language)	
	Fitting function (dedicated INFORM language)	
	Inserting function (dedicated INFORM language)	
Functions that Increase Reliability	Search function, snagging prevention function	
Teaching Method	Semi-automatic adjustment method using Engineering Support Tool for MotoFit functions; runs on customer's personal computer.	
6-axis Force Sensor	Dedicated sensor specified by Yaskawa Electric (provided as an accessory at delivery); two types with rating of 200N and 1000N	
Conditions for Applicable Workpieces	Geometry	Cylindrical
	Fit clearance	h7/H7 or greater; clearance must be at least 10 μm
	Chamfer	C 0.1 or more
	Fit depth	20 mm or less
	Initial position error	± 1 mm or less
	Initial posture error	± 1.0 deg or less
Other Functions	Force-tracking function (dedicated macro command)	
	Pressing function (dedicated macro command)	
	Force-sensing function (dedicated macro command)	
Support for MotoPlus	Force control service API (must be specified as option)	

		6-AXIS SENSOR RATED 200N	6-AXIS SENSOR RATED 1000N*
Rated Load	Fx, Fy, Fz	200N	1000N
	Mx, My, Mz	4Nm	30Nm
Load protection stopper to work	Fx, Fy, Fz	1000N	5000N
	*Mx, My, Mz	6Nm	50Nm
Resolution		0.024N	0.12N
Supply voltage		24V DC	24V DC
Sampling Frequency		2kHz	2kHz
Dustproof / Waterproof		IP65	IP65
Inductive Noise Immunity		1500V	1500V
Size (mm)		φ80 x H32.5	φ90 x H40
Weight (g)		360	580

ROBOT COMPATIBILITY

- MHJ
- MH3
- MH5
- MH5L
- MH6
- MH12
- HP20
- MPP3
- SIA5
- SIA10
- SIA20
- SDA5
- SDA10
- SDA10

Installation of MotoFit sensor may change robot range of motion.

Installation of MotoFit sensor must be considered when evaluating robot wrist suitability for a given project.

ENVIRONMENTAL REQUIREMENTS

- Ambient operating temperature: 0 to +40° C
- Less moisture and dry (humidity: 20 to 80% RH, non-condensing)
- Free from dust, dirt, oil mist, and water drop
- Free from corrosive gases or liquid, or explosive gases or liquid
- Free from excessive impact or vibration (4.9 m/s² (0.5 G) or less)
- Free from large electrical noise (TIG welder, etc.)
- The flatness for installation is 0.5 mm or less

motoman.com

Yaskawa America, Inc. | Motoman Robotics Division
100 Automation Way | Miamisburg, OH 45342
Tel: 937.847.6200 | Fax: 937.847.6277