



MPL80 II

PALLETIZING | DE-PALLETIZING

KEY BENEFITS

Improve cycle times for palletizing and other order-handling tasks

High reliability and ease of maintenance

Performance-driven design

SPECIFICATIONS

80 kg maximum payload

3,291 mm vertical reach

2,061 mm horizontal reach

CONTROLLERS



DX200



FS100



MLX200

- High-performance, 5-axis robot with 80 kg payload capacity.
- Highly versatile, the MPL80 II robot is ideal for case palletizing, bag palletizing, order picking and many logistical tasks for end-of-line or distribution center automation.
- Extensive 3,291 mm vertical reach, combined with 2,061 mm horizontal reach, enables palletizing loads up to 95 in. tall.
- Internally routed airlines and cables from base to end-of-arm tool maximize reliability.
- Internally routed fieldbus connection to T-axis/tool.
- NSF-H1 certified food-grade lubricant option available for food or consumer product packaging environment.
- Compact base and slim-arm design of the MPL80 II is ideally suited for minimum floorspace installation requirements.
- Available with PalletSolver™, Yaskawa Motoman's operator-friendly palletizing software suite, for fast and easy creation of palletizing patterns.
 - PalletSolver's offline pattern generation tool with intuitive graphical interface allows quick changeovers without halting production.
 - Highly customizable to each palletizing system.
 - Directly imports pallet patterns generated in widely-used TOPS® or CAPE software.

MPL80 II ROBOT

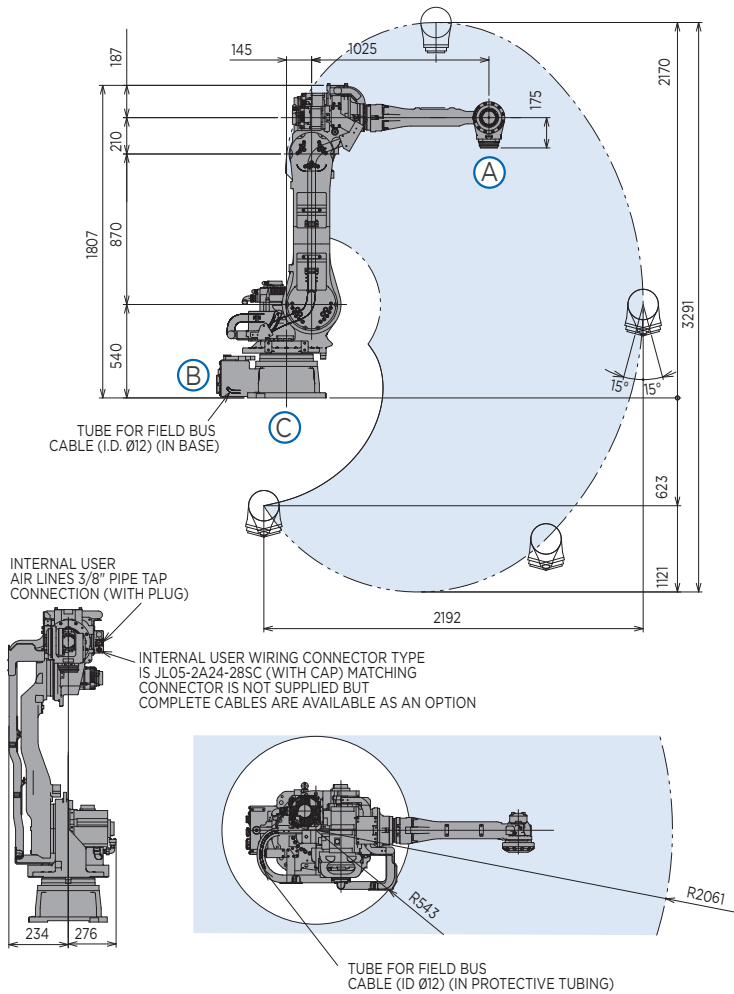

VIEW A

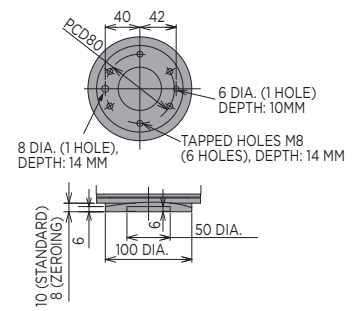

VIEW B

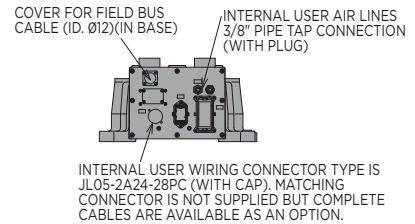

VIEW C

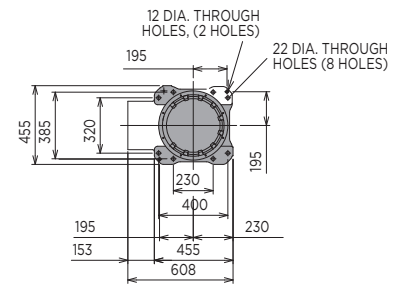

All dimensions are metric (mm) and for reference only.
Request detailed drawings for all design/engineering requirements.

SPECIFICATIONS

Axes	Maximum motion range [°]	Maximum speed [°/sec.]	Allowable moment [N•m]	Allowable moment of inertia [kg•m ²]	Controlled axes	5
S	±180	170	-	-	Maximum payload [kg]	80
L	+135/-90	170	-	-	Repeatability [mm]	±0.07
U	+35/-160	170	-	-	Horizontal reach [mm]	2,061
B	±15	170	78.4	16	Vertical reach [mm]	3,291
T	±360	350	20.5	6.1	Weight [kg]	550
					Power requirements DX200 MLX200	3-phase; 240/480/575 VAC at 50/60 Hz 3-phase, 230 VAC at 50/60 Hz
					Power rating [kVA]	4.0

OPTIONS

- NSF-H1 certified food-grade lubricants
- Extended length manipulator cables
- PalletSolver - revolutionary palletizing software
- MotoSight™ - easy to integrate vision software

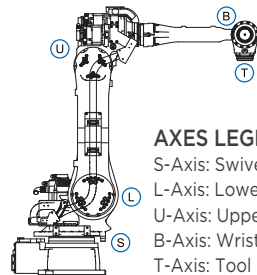

AXES LEGEND
S-Axis: Swivel Base
L-Axis: Lower Arm
U-Axis: Upper Arm
B-Axis: Wrist Bend
T-Axis: Tool Flange

Yaskawa America, Inc.
Motoman Robotics Division

100 Automation Way
Miamisburg, OH 45342
Tel: 937.847.6200
Fax: 937.847.6277

motoman.com

YASKAWA