

# MLX200 HARDWARE INSTALLATION & SOFTWARE UPGRADE

## INSTRUCTIONS

---

Upon receipt of the product and prior to initial operation, read these instructions thoroughly and retain for future reference.

---

Part Number: 168283-1CD  
Revision: 8

Copyright © 2015, Yaskawa America, Inc.

#### Terms of Use and Copyright Notice

All rights reserved. This manual is freely available as a service to Yaskawa customers to assist in the operation of Motoman robots, related equipment and software. This manual is copyrighted property of Yaskawa and may not be sold or redistributed in any way. You are welcome to copy this document to your computer or mobile device for easy access but you may not copy the PDF files to another website, blog, cloud storage site or any other means of storing or distributing Online content.

Printed in the United States of America

First Printing, 2015

Yaskawa America, Inc.  
Motoman Robotics Division  
100 Automation Way  
Miamisburg, OH 45342  
Phone: 937-847-6200

[www.motoman.com](http://www.motoman.com)



## MANDATORY

- This manual explains setup, diagnosis, maintenance, hardware, etc. of the MLX200 Hardware Installation & Software Upgrade. Read this manual carefully and be sure to understand its contents before using the Hardware Installation & Software Upgrade.
- General items related to safety are listed in Chapter 1. To ensure correct and safe operation, carefully read the section.



## CAUTION

- Some drawings in this manual are shown with the protective covers or shields removed for clarity. Be sure that all covers and shields are replaced before operating this product.
- The drawings and photos in this manual are representative examples, and differences may exist between them and the delivered product.
- YASKAWA may modify this model without notice when necessary due to product improvements, modifications, or changes in specifications. If such a modification is made, the manual number will also be revised.
- If your copy of the manual is damaged or lost, contact a YASKAWA representative to order a new copy. The representatives are listed on the back cover. Be sure to tell the representative the manual number listed on the front cover.
- YASKAWA is not responsible for incidents arising from unauthorized modification of its products. Unauthorized modification voids your product's warranty.

We suggest that you obtain and review a copy of the ANSI/ RIA National Safety Standard for Industrial Robots and Robot Systems (ANSI/ RIA R15.06-2012). You can obtain this document from the Robotic Industries Association (RIA) at the following address:

Robotic Industries Association  
900 Victors Way  
P.O. Box 3724  
Ann Arbor, Michigan 48106  
TEL: (734) 994-6088  
FAX: (734) 994-3338  
[www.roboticsonline.com](http://www.roboticsonline.com)

Ultimately, well-trained personnel are the best safeguard against accidents and damage that can result from improper operation of the equipment. The customer is responsible for providing adequately trained personnel to operate, program, and maintain the equipment. **NEVER ALLOW UNTRAINED PERSONNEL TO OPERATE, PROGRAM, OR REPAIR THE EQUIPMENT!**

We recommend approved Yaskawa training courses for all personnel involved with the operation, programming, or repair of the equipment.

This equipment has been tested and found to comply with the limits for a Class A digital device, pursuant to part 15 of the FCC rules. These limits are designed to provide reasonable protection against harmful interference when the equipment is operated in a commercial environment. This equipment generates, uses, and can radiate radio frequency energy and, if not installed and used in accordance with the instruction manual, may cause harmful interference to radio communications.

## Notes for Safe Operation

Read this manual carefully before installation, operation, maintenance, or inspection of the Hardware Installation & Software Upgrade.

In this manual, the Notes for Safe Operation are classified as “WARNING,” “CAUTION,” “MANDATORY,” or “PROHIBITED.”



### WARNING

Indicates a potentially hazardous situation which, if not avoided, could result in death or serious injury to personnel.



### CAUTION

Indicates a potentially hazardous situation which, if not avoided, could result in minor or moderate injury to personnel and damage to equipment. It may also be used to alert against unsafe practices.



### MANDATORY

Always be sure to follow explicitly the items listed under this heading.



### PROHIBITED

Must never be performed

Even items described as “CAUTION” may result in a serious accident in some situations. At any rate, be sure to follow these important items.



To ensure safe and efficient operation at all times, be sure to follow all instructions, even if not designated as “CAUTION” and “WARNING.”



## WARNING

- Confirm that no person is present in the P-point maximum envelope of the manipulator and that you are in a safe location before:
  - Turning ON the MLX200 Control Module power
  - Moving the manipulator with teach pendant or MLX HMI
  - Running the system in the check mode
  - Performing automatic operations

Injury may result if anyone enters the P-point maximum envelope of the manipulator during operation. Always press the emergency stop button immediately if there are problems. The emergency stop button is located on the right of the teach pendant.

- Observe the following precautions when performing teaching operations within the P-point maximum envelope of the manipulator:
  - View the manipulator from the front whenever possible.
  - Always follow the predetermined operating procedure.
  - Ensure that you have a safe place to retreat in case of emergency.

Improper or unintended manipulator operation may result in injury.

- Before operating the manipulator, check that servo power is turned OFF when the emergency stop button on teach pendant is pressed. When the servo power is turned **OFF**, the **SERVO ON INDICATOR** on the teach pendant or MLX HMI is turned **OFF**.

Injury or damage to machinery may result if the Emergency Stop circuit cannot stop the positioner during an emergency. The positioner should not be used if the EMERGENCY STOP buttons do not function.

*Figure 1: EMERGENCY STOP Button*



- Release the EMERGENCY STOP button. Once this button is released, clear the cell of all items which could interfere with the operation of the positioner. Then turn servo power ON.

Injury may result from unintentional or unexpected positioner motion.

*Figure 2 : Release of EMERGENCY STOP Button*





## CAUTION

- Perform the following inspection procedures prior to conducting manipulator teaching. If problems are found, repair them immediately, and be sure that all other necessary processing has been performed.
  - Check for problems in manipulator movement.
  - Check for damage to insulation and sheathing of external wires.

The optional teach pendant can be damaged if it is left in the P-point maximum envelope of the manipulator's work area, on the floor, or near fixtures.

- Read and understand the Explanation of the Warning Labels before operating the manipulator.

## Definition of Terms Used Often in This Manual

The MOTOMAN is the YASKAWA industrial robot product.

The MOTOMAN consists of the manipulator, the drive panel, and manipulator cables.

In this manual, the equipment is designated as follows.

Equipment	Manual Designation
MLX200 Drive Panel	MLX Drive Panel



## Registered Trademark

In this manual, names of companies, corporations, or products are trademarks, registered trademarks, or brand names for each company or corporation. The indications of (R) and TM are omitted.

## Explanation of Warning Labels

The following warning labels are attached to the manipulator.

Fully comply with the precautions on the warning labels.

 <b>WARNING</b>	
<ul style="list-style-type: none"><li>• The label described below is attached to the manipulator. Observe the precautions on the warning labels.</li><li>• Failure to observe this caution may result in injury or damage to equipment.</li></ul>	
	<b>▲ WARNING</b> Moving parts may cause injury
	<b>▲ WARNING</b> Do not enter robot work area.
Refer to the manipulator manual for the warning label location.	



---

## Table of Contents

1	Introduction .....	1-1
1.1	MLX200 Robot Control Module Components .....	1-1
1.1.1	User Supplied Components.....	1-2
1.2	For Your Safety.....	1-2
1.3	Special Training .....	1-3
1.4	Motoman Manual List .....	1-4
1.5	Personnel Safety .....	1-5
1.6	Motoman Safety.....	1-7
1.6.1	Installation and Wiring Safety .....	1-7
1.6.2	Work Area Safety .....	1-9
1.6.3	Operation Safety .....	1-10
1.7	Notes for Moving and Transferring the MOTOMAN .....	1-11
1.8	Notes on MOTOMAN Disposal.....	1-12
2	Product Confirmation .....	2-1
2.1	Before Unpacking .....	2-1
2.2	Unpacking.....	2-1
2.3	Contents Confirmation .....	2-1
2.3.1	Optional Teach Pendant (Fuji).....	2-2
2.4	Warranty ID Confirmation .....	2-3
2.5	Customer Support Information.....	2-5
3	Installation.....	3-1
3.1	Handling Procedure.....	3-1
3.1.1	Moving the Drive Panel .....	3-1
3.2	Installation Environment .....	3-1
3.3	Location .....	3-2
3.4	Cut-Outs for Emergency Stop and Auto/ Manual Buttons .....	3-9

4	Connections .....	4-1
4.1	Notes on Cable Junctions .....	4-2
4.2	Power Supply .....	4-3
4.2.1	Three-Phase Power Supply .....	4-3
4.2.2	Primary Power Supply Breaker/ Fuse Installation .....	4-3
4.3	Connection Methods .....	4-5
4.3.1	Connecting the Primary Power Supply .....	4-5
4.3.2	Connecting the Manipulator Cable .....	4-6
4.3.3	Dual Robot Connection .....	4-7
5	Turning ON and OFF the Power Supply .....	5-1
5.1	Turning ON the Main Power Supply .....	5-1
5.2	Turning OFF the Power Supply .....	5-1
5.2.1	Turning OFF the Servo Power (Emergency Stop) .....	5-1
6	Test of Program Operation .....	6-1
6.1	Movement of the Axes .....	6-2
7	System Setup .....	7-1
7.1	Home Position Calibration .....	7-1
7.1.1	Home Position Calibration .....	7-2
7.1.2	Calibrating Operation .....	7-3
7.1.3	Home Position of the Robot .....	7-6
7.1.4	Purpose of Position Check Operation .....	7-7
7.1.5	Procedure after the Alarm .....	7-7
7.2	Tool Data Setting .....	7-8
7.2.1	Registering Tools .....	7-8
7.2.2	Tool Calibration .....	7-15
8	MLX200 Specification .....	8-1
8.1	Specification List .....	8-2
8.1.1	Panel Heat Loss (Estimate) .....	8-2
8.2	Equipment Configuration .....	8-3
8.2.1	Arrangement of Units and Circuit Boards .....	8-3

9	Description of Units and Circuit Boards .....	9-1
9.1	SERVOPACK .....	9-9
9.1.1	SERVOPACK Configuration.....	9-9
10	MLX200 Control Module Software Version Upgrade Procedure .....	10-1
10.1	Upgrade the Application on the MLX200 Control Module.....	10-1
10.2	Export Robot Data for RSLogix Ladder .....	10-4
10.3	Export non-MLX Tasks from the RSLogix Ladder .....	10-5
10.4	Download New Version of MLX200 Control Module Software .....	10-5
10.5	Setup I/O Configuration in RSLogix Ladder.....	10-5
10.6	Import Tasks into the New RSLogix Ladder .....	10-5
10.7	Import the Robot Data into RSLogix .....	10-6
10.8	Configure the new MLX200-HMI file to see the “MLX200x_x_x” processor. ....	10-6
10.9	Teach Pendant Software Upgrade. ....	10-7
11	Teach Pendant Software Upgrade Procedure (Fuji Pendant) .....	11-1
11.1	Configure PC to use a Static IP .....	11-2
11.1.1	Prepare Pendant to Set the IP Address for the NEW/ UN-PROGRAMMED System.....	11-3
11.1.2	Prepare Pendant to Change IP Address for an Upgraded System .....	11-3
11.1.3	Setting IP Address for Pendant .....	11-4
11.2	Setup the Fuji V-SFTV5 Monitouch Program .....	11-5
11.3	Transfer Screen Data to Teach Pendant (Version 5) .....	11-7
11.4	Setup the Fuji V-SFTV6 Monitouch Program .....	11-9
11.5	Transfer Screen Data to Teach Pendant (Version 6) .....	11-11
11.6	Install the MLX Version Label .....	11-13
12	Sigma-5 Amplifier Parameter Upgrade Procedure .....	12-1
13	HMI Communications Setup Procedure.....	13-1
13.1	Version Note .....	13-1
13.2	Configuring Factory Talk Administration Console.....	13-1
13.3	Copy PLC Design to Runtime.....	13-6
13.4	Starting up the HMI.....	13-8

---

Appendix A .....	A-1
A.1 Rockwell MobileView Support .....	A-1
A.1.1 Overview .....	A-1
A.1.2 Components .....	A-1
A.1.3 Wiring .....	A-2
A.1.4 Software .....	A-6
A.1.5 External References .....	A-6

## 1 Introduction

The MLX200 Control Module solution enables the user to replace the traditional robot controller with PLC-based software and general purpose motion control hardware.

The Hardware Installation & Software Upgrade enables the user to integrate select Yaskawa manipulator models with Rockwell Automation ControlLogix Programmable or CompactLogix Automation Controller (PAC) and RSLogix 5000 development software via a customized set of MLX200 Control module software, Add-On Instructions and associated computer hardware.

Fig. 1-1: Layout (MPL160 Shown)

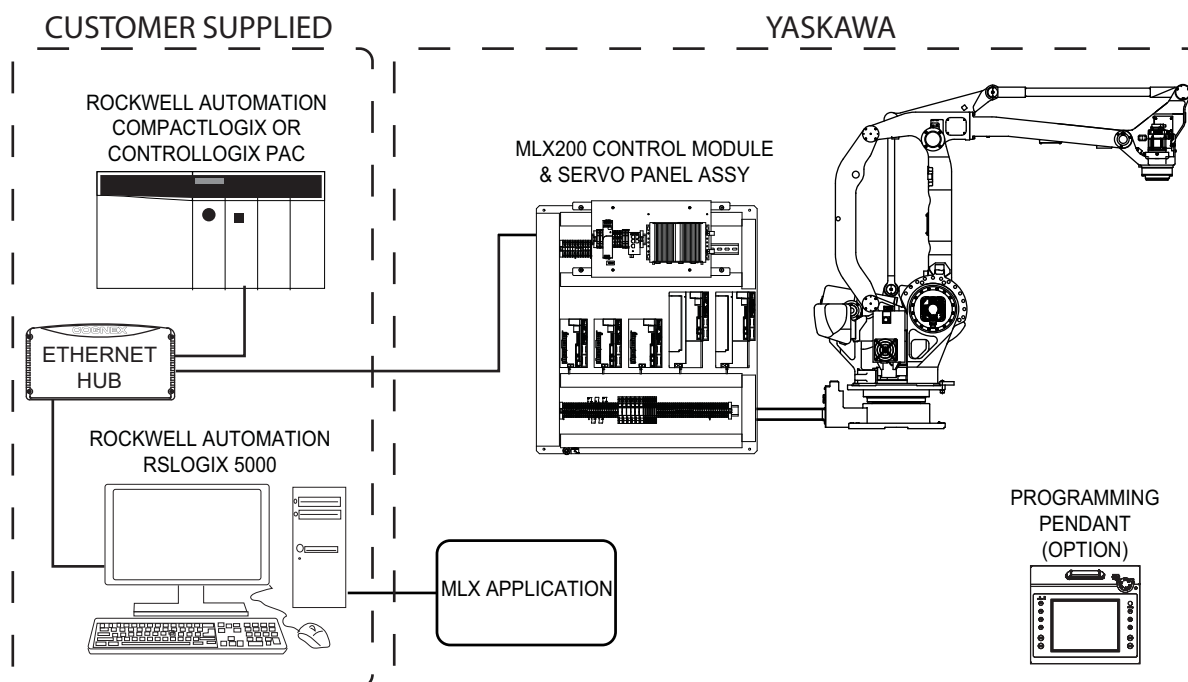

### 1.1 MLX200 Robot Control Module Components

Several Hardware Installation & Software Upgrade configurations are available and include the appropriate control panel, servo amplifiers, cables, and components required to interface with the Rockwell ControlLogix or CompactLogix controller and target manipulator.

The MLX200 Robot Control Module includes the runtime from the MLX200 software. This is the operating system for the robot and provides full kinematics for the supplied manipulator. In addition, the software provides interference zones, robot jogging controls in multiple coordinate systems, and tool frame control. The control module handles all motion control tasks.

### 1.1.1 User Supplied Components

When using an Hardware Installation & Software Upgrade controlled robot, the user must supply the following items:

- Rockwell Programmable Automation Controller (PAC). Either;
  - ControlLogix: 1756-L61 minimum
  - CompactLogix: L2 or L3 controller minimum, with 1 MB of memory
- Ethernet/ IP Communication port
- Rockwell Automation RSLogix 5000 software (v19)
- Switch (managed switch suggested)
- User Application
- I/O and safety modules
- FactoryTalk View Machine Edition or Studio Edition (v6.1)

Many of these items can be purchased from Yaskawa. Contact your Yaskawa sales representative for more information.

## 1.2 For Your Safety

Robots generally have requirements which are different from other manufacturing equipment, such as larger working areas, high-speed operation, rapid arm movements, etc., which can pose safety hazards.

Read and understand the instruction manuals and related documents, and observe all precautions in order to avoid the risk of injury to personnel and damage to equipment.

It is the user's responsibility to ensure that all local, state, and national codes, regulations rules, or laws relating to safety and safe operating conditions are met and followed.



## MANDATORY

- Teaching maintenance of the robot must conform to:
  - Industrial Safety and Health Law
  - Enforcement Order of Industrial Safety and Health Law
  - Ordinance of Industrial Safety and Health Law
- Other related laws are:
  - Occupational Safety and Health Act in USA
  - Factory Act (Gewerbeordnung) in Germany
  - Health and Safety at Work, etc. Act in UK
  - EC Machinery Directive 98/37/EC
- Prepare
  - SAFETY WORK REGULATIONS  
based on concrete policies for safety management complying with related laws.
- Observe the
  - MANIPULATING INDUSTRIAL ROBOTS-SAFETY (ISO 10218)  
for safe operation of the robot. (Japan Only) (JIS B 8433)
- Reinforce the
  - SAFETY MANAGEMENT SYSTEM  
by designating authorized workers and safety managers, as well as giving continuing safety education.
- Teaching and maintaining the robot are specified as “Hazardous Operations” in the Industrial Safety and Health Law

### 1.3 Special Training



## MANDATORY

- Persons who teach or inspect the manipulator must undergo required training before using the manipulator.
- For more information on training, inquire at the nearest YASKAWA branch office.

The telephone numbers are listed on the back cover of this manual.

## 1.4 Motoman Manual List

The instruction manuals below describe how the manipulators with the MLX200 Hardware Installation & Software Upgrade are different from those with the standard DX100/ DX200/ FS100 Controller.



### MANDATORY

Read this instruction manual thoroughly together with the following instruction manuals:

- Yaskawa Motoman Manipulator Instructions for your model. Disregard all references to the “DX100 or DX200” Controller when reading using the manipulator manual. This manual is to be used for manipulator hardware only.
  - Motoman-MH5S Instructions (P/N 160475-1CD)
  - Motoman-MH5S II Instructions (P/N 172401-1CD)
  - Motoman-MH5LS Instructions (P/N 161052-1CD)
  - Motoman-MH5LS II Instructions (P/N 170780-1CD)
  - Motoman-MH12 Instructions (P/N 167105-1CD)
  - Motoman-HP20D Instructions (P/N 168283-1CD)
  - Motoman-SIA20D Instructions (P/N 156387-1CD)
  - Motoman-MPK50 Instructions (P/N 156865-1CD)
  - Motoman-MPL80 Instructions (P/N 157283-1CD)
  - Motoman-MPL80 II Instructions (P/N 170904-1CD)
  - Motoman-MPL160 Instructions (P/N 156830-1CD)
  - Motoman-MPL160 II Instructions (P/N 172536-1CD)
  - Motoman-MPL300 Instructions (P/N 157284-1CD)
  - Motoman-MPL300 II Instructions (P/N 173124-1CD)
- MLX200 Software and Operation Manual (P/N 168542-1CD)

Confirm that you have the appropriate manipulator manual and MLX200 Software and Operation Manual on hand. If any manuals are missing, contact your salesman from YASKAWA's local branch office. The relevant telephone numbers are listed on the last page.



## 1.5 Personnel Safety

The entire manipulator P-point maximum envelope is potentially dangerous.

All personnel working with the MOTOMAN (safety administration, installation, operation, and maintenance personnel) must always be prepared and “Safety First” minded, to ensure the safety of all personnel.



### CAUTION

- Avoid any dangerous actions in the area where the MOTOMAN is installed.

There is a danger of injury if there is contact with the manipulator or peripheral equipment.

- Please take strict safety precautions by placing signs such as “Flammable”, “High Voltage”, “Waiting”, and “Off-limits to Unauthorized Personnel” in necessary areas in the factory.

Failure to observe these cautions may result in fire, electric shock, or injury due to contact with the manipulator and other equipment.

- Strictly observe the following items:
  - Always wear approved work clothes (no loose-fitting clothes).
  - Do not wear gloves when operating the MOTOMAN.
  - Do not allow underwear, shirts, or neckties to hang out from the work clothes.
  - Do not wear large jewelry, such as earrings, rings, or pendants.

Always wear protective safety equipment such as helmets, safety shoes (with slip-proof soles), face shields, safety glasses, and gloves as necessary.

Improper clothing may result in injury.

- Unauthorized persons should not approach the manipulator or associated peripheral equipment.

Failure to observe this caution may result in injury due to contact with the Hardware Installation & Software Upgrade, the workpiece, the robot, etc.



## CAUTION

- Never forcibly move the manipulator axes.

Failure to observe this caution may result in injury or equipment damage.

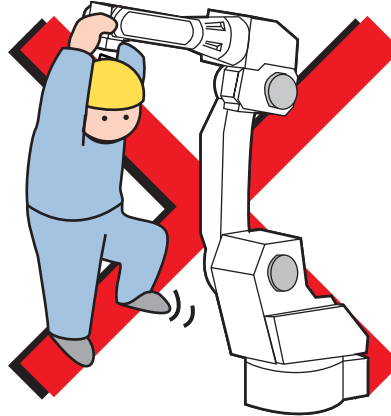

- Never lean on Hardware Installation & Software Upgrade or other controllers, and avoid inadvertently pushing buttons.

Failure to observe this caution may result in injury or damage by unexpected movement of the manipulator.

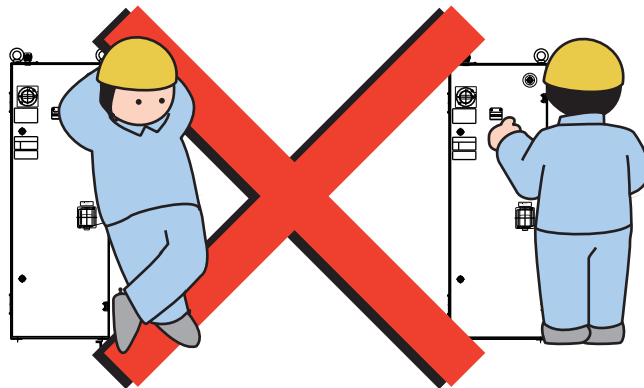

- Never allow unauthorized personnel to touch the Hardware Installation & Software Upgrade during operation.

Failure to observe this caution may result in injury or damage resulting from unexpected movement of the manipulator.

## 1.6 Motoman Safety

### 1.6.1 Installation and Wiring Safety

In planning installation, adapt an easy to observe arrangement to ensure safety. Take safety into consideration when planning the installation. Observe the following when installing the manipulator:

- Select an area such as that described below to install the manipulator:  
Confirm that the area is large enough so that the fully extended manipulator arm with tool will not reach a side wall, safeguarding, or the drive panel.

Failure to observe this Warning may result in injury or damage resulting from unexpected movement of the manipulator.

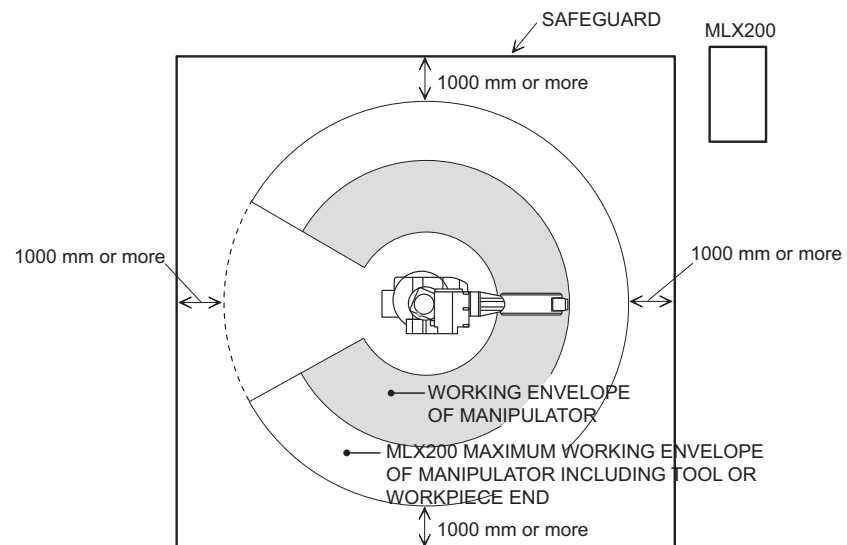

- Perform grounding in accordance with all applicable electrical codes.

Failure to observe this caution may result in fire or electric shock.



## CAUTION

- Operation of cranes, slings, or forklifts should only be performed by authorized personnel.

Failure to observe this precaution may result in injury or equipment damage.

**CAUTION**

MOTOMAN should be lifted with a crane using appropriately rated cable or strapping threaded through the provided lifting eyes and lifted in an upright posture as described in the manipulator instruction manual.

Failure to observe these precautions may cause the manipulator to turn downward, potentially causing injury or damage to equipment.

**CAUTION**

- When lifting the MLX200 drive panel, please check the following:
  - As a rule, handling of the MLX200 drive panel can be performed by two or more people.
  - The MLX200 drive panel weighs approximately 31 - 47 kg (69 - 104 lbs). Be sure movers are strong enough to handle this weight.

Failure to observe this caution may result in injury or damage to equipment.

- If storing the manipulator temporarily before installation, be sure to place it on a stable and flat surface and take precautions to prevent unauthorized personnel from touching it.

Failure to observe this precaution may result in injury or damage to equipment.

**CAUTION**

- Be sure there is sufficient room for maintenance on the manipulator, Hardware Installation & Software Upgrade, and other peripheral equipment.

Failure to observe this precaution could result in injury during maintenance.

- To ensure safety, be sure to operate the drive panel from a location where the manipulator is easily visible.

Operation by unauthorized personnel may result in injury or equipment damage.

- Install the MLX200 drive panel outside the safeguarding of the manipulator's safety enclosure.

Failure to observe this precaution may result in injury or damage to equipment resulting from contact with the manipulator.

**CAUTION**

- Install the manipulator using bolts of the size and type specified for each MOTOMAN in the MOTOMAN INSTRUCTION MANUAL.

Failure to observe this caution may result in injury or damage to equipment.

**1.6.2 Work Area Safety**

Carelessness contributes to serious accidents in the work area.

To ensure safety, enforce the following precautions:

- Install a safeguarding around the manipulator to prevent any accidental contact with the manipulator while power is ON. Post a warning sign stating “Off-limits During Operation” at the entrance of the enclosure. The gate of the safeguarding must be equipped with a safety interlock. Be sure the interlock operates correctly before use.

Failure to observe this caution may result in a serious accident due to contact with the manipulator.

**CAUTION**

- Store tools and similar equipment in proper locations outside of the enclosure.

Tools and loose equipment should not be left on the floor around the manipulator, Hardware Installation & Software Upgrade, or welding fixture, etc., as injury or damage to equipment can occur if the manipulator comes in contact with objects or equipment left in the work area.

**1.6.3 Operation Safety**

<ul style="list-style-type: none"> <li>When attaching a tool such as the welding torch to the manipulator, be sure to turn OFF the power supply of the Hardware Installation &amp; Software Upgrade and the tool, lock the switch, and display a warning sign.</li> </ul> <p>Turning the power ON during tool installation may cause electric shock or injury due to unexpected movement of the manipulator.</p>
<ul style="list-style-type: none"> <li>Never exceed the rated capacity of the manipulator (capacity can be found in the specifications section of the manipulator manual.)</li> </ul> <p>Failure to observe this caution may result in injury or damage to equipment.</p>
<ul style="list-style-type: none"> <li>Teach jobs from outside the manipulator's work area whenever possible.</li> </ul>
<ul style="list-style-type: none"> <li>Observe the following precautions when performing teaching operations within the P-point maximum envelope of the manipulator: <ul style="list-style-type: none"> <li>Always view the manipulator from the front.</li> <li>Always follow the predetermined operating procedure.</li> <li>Always have an escape plan in mind in case the manipulator comes toward you unexpectedly.</li> <li>Ensure that you have a place to retreat to in case of emergency.</li> </ul> </li> </ul> <p>Improper or unintentional manipulator operation can result in injury.</p>

<ul style="list-style-type: none"> <li>Before operating the manipulator, check that all emergency stop buttons are pressed. And confirm that the servo power is turned OFF.</li> </ul> <p>Injury or damage to machinery may result if the manipulator cannot be stopped in case of an emergency.</p>
<ul style="list-style-type: none"> <li>Prior to performing the following operations, be sure that no one is in the P-point maximum envelope of the manipulator when: <ul style="list-style-type: none"> <li>Turning ON the Hardware Installation &amp; Software Upgrade power</li> <li>Moving the manipulator.</li> <li>Running the system in the check mode</li> <li>Performing automatic operations</li> </ul> </li> </ul> <p>Injury may result from contact with the manipulator if persons enter the P-point maximum envelope of the manipulator.</p> <p>Press the emergency stop button immediately if there are problems.</p>

**CAUTION**

- Perform the following inspection procedures prior to teaching the manipulator. If problems are found, correct them immediately, and be sure that all other necessary tasks have been performed.
  - Check for problems in manipulator movement.
  - Check for damage to the insulation and sheathing of external wires.

- Always return the optional teach pendant to a safe location after use.

If the teach pendant is inadvertently left on the manipulator, a fixture, or on the floor, the manipulator or a tool could collide with it during manipulator movement, possibly causing injury or equipment damage.

**MANDATORY**

- Persons operating or inspecting the manipulator should be trained as required by applicable laws and company policies.
- Refer to *section 1.3 “Special Training” on page 1-3*

**1.7 Notes for Moving and Transferring the MOTOMAN**

When moving or transferring the Motoman, observe the following safety precautions:

**CAUTION**

- Attach the instructions to the drive panel cabinet so that all users have access to necessary manuals. See *section 1.4 “Motoman Manual List” on page 1-4* for a complete list of manuals.

If any manuals are missing, contact your Yaskawa representative.

- If the warning labels on the manipulator and Hardware Installation & Software Upgrade are illegible, clean the labels so that they can be read clearly. Note that some local laws may prohibit equipment operation if safety labels are not in place.

Contact your YASKAWA representative if you require new warning labels.

- When the MOTOMAN is transferred, it is recommended to check with Yaskawa which is listed on back cover of this manual.

Incorrect installation or wiring may result in personal injury and property damage.

## 1.8 Notes on MOTOMAN Disposal



- Never modify the manipulator.

Failure to observe this precaution could result in injury or damage resulting from fire, power failure, or operation error.



- When disposing of the MOTOMAN, follow the applicable national/local laws and regulations.
- Anchor the manipulator well, even when temporarily storing it before disposal.

Failure to observe this precaution may result in injury due to the manipulator falling down.



## 2 Product Confirmation

### 2.1 Before Unpacking

Carefully inspect all shipping crates for evidence of damage during transit. Pay special attention to tilt and shock indication labels on the exterior of the containers. If any damage is indicated, request that the carrier's agent be present at the time the container is unpacked.

### 2.2 Unpacking

The MLX200 drive panel is shipped in a crate along with any miscellaneous hardware and any accessories ordered.

### 2.3 Contents Confirmation

Confirm the contents of the delivery when the product arrives.

Standard delivery includes the following five items (Information for the content of optional goods is given separately):

- Manipulator
- MLX200 Drive Panel with MLX200 Robot Control Module
- Regen Cabinet and Cable
- Manipulator Cables (Between Manipulator and MLX200 Drive Panel)
- Complete Set of Manuals

*Fig. 2-1: Standard Items*

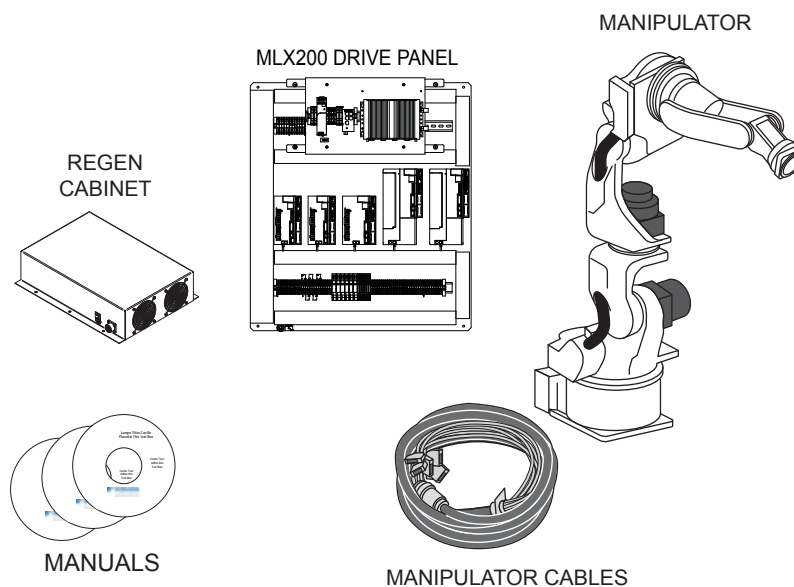

## 2.3.1 Optional Teach Pendant (Fuji)



**Yaskawa discontinued sale of this Teach Pendant model as of October 2015. Refer to *Appendix A* for more information on an alternative solution.**

The optional Teach Pendant (see *Fig. 2-2*) provides a means of programmer/ operator interaction with the Hardware Installation & Software Upgrade system. The pendant features a 7.5-inch, color LCD, touch-screen display (640 X 480 VGA).

The features include a menu-driven interface unique to the MLX200 Control Module environment, by using the Teach Pendant, the operator can teach and adjust the robots points; perform programming, editing, maintenance, and diagnostic functions. (The sequence of motions is not programmed through the Teach Pendant, this is handled through RSLogix application logic.)

*Figure 2-2: MLX200 Teach Pendant*

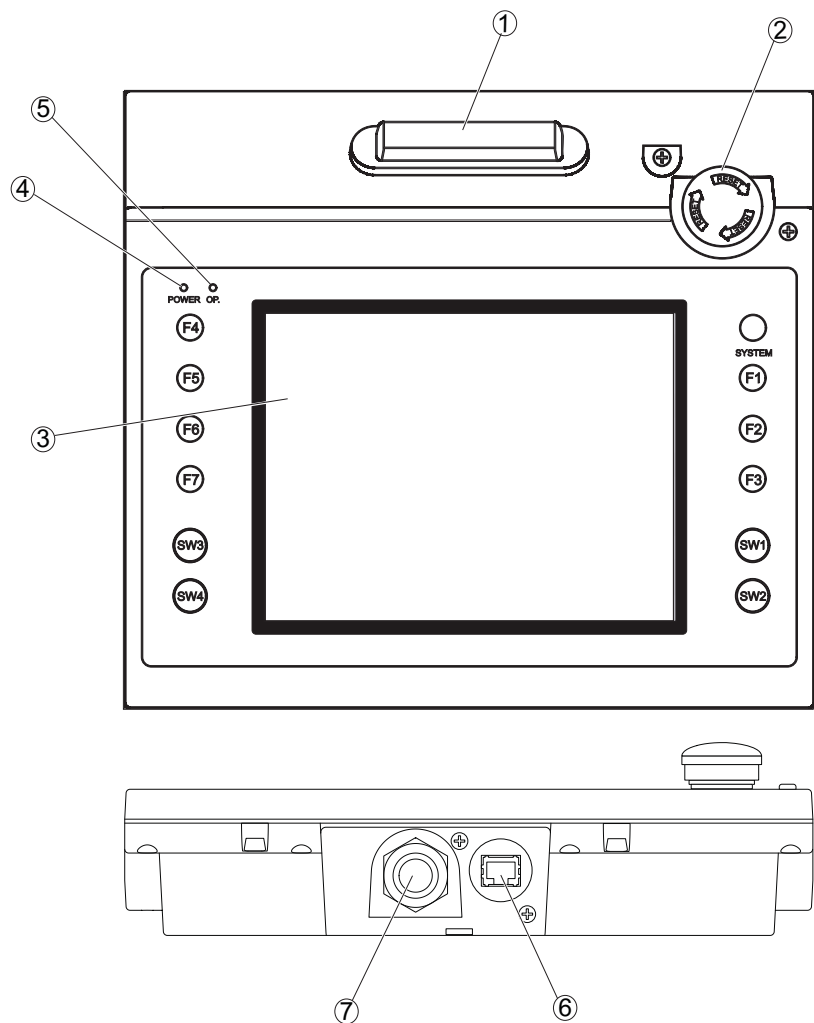

Call Out	Name	Description
1	Enable/ Deadman Switch	Enables and disables the teach pendant. The unit is operative when the switch is pressed.
2	Emergency Stop Switch	Implements an emergency stop condition and sends an emergency stop signal to the external equipment.
3	Display	7.5-inch, color LCD, touch-screen display (640 X 480 VGA)
4	Power Lamp (POWER)	A green light illuminates when power is on to the pendant, and is operating normally. The lamp flashes when the backlight fails (burned-out backlight, etc.)
5	Operation Lamp (OP)	A green light illuminates when the pendant is operative, and goes off when the pendant is inoperative.
6	100BASE-TX/ 10BASE-T Connector (LAN)	Used for an Ethernet connection.
7	IO and Power Cable Connection Port	Communication and power port for the pendant.

## 2.4 Warranty ID Confirmation

Confirm that the warranty ID pasted on the manipulator and hardware match.

The warranty ID stickers are affixed as shown in the figure.

**THE MANIPULATOR, DRIVE PANEL AMPLIFIERS, CONTROLLER MODULE, AND REGEN CABINET SHOULD HAVE THE SAME WARRANTY ID.**

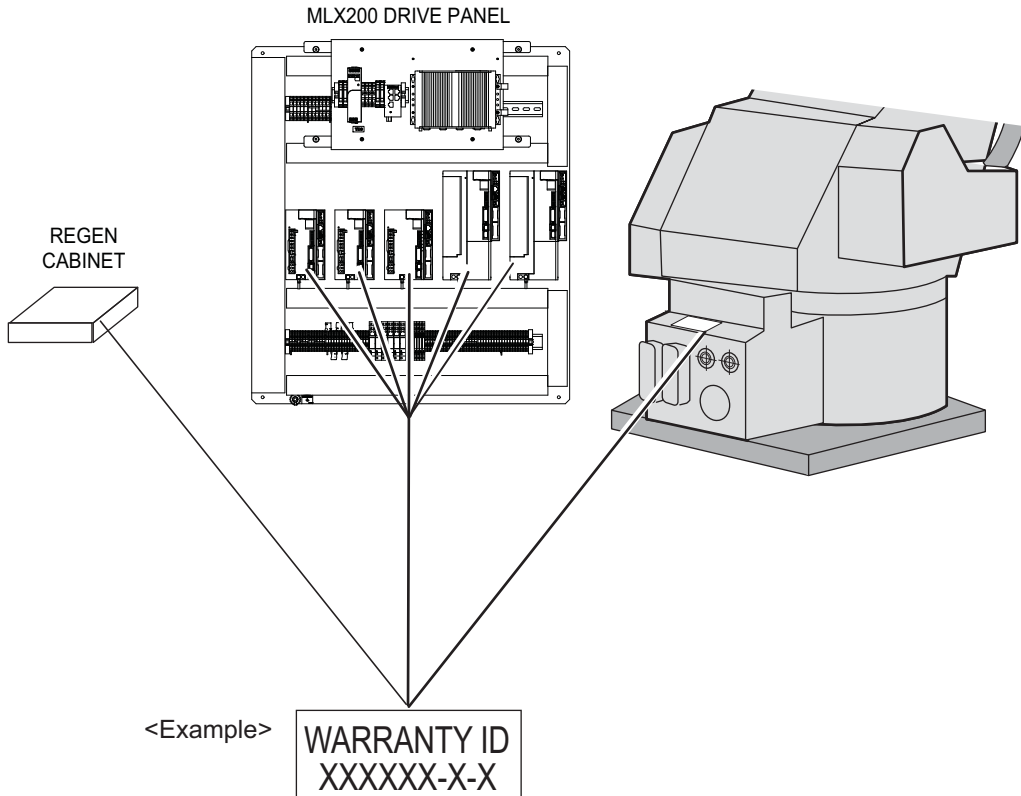

## 2.5 Customer Support Information

If you need assistance with any aspect of your Hardware Installation & Software Upgrade system, please contact Motoman Customer Support at the following 24-hour telephone number:

**(937) 847-3200**

For **routine** technical inquiries, you can also contact Motoman Customer Support at the following e-mail address:

[techsupport@motoman.com](mailto:techsupport@motoman.com)

When using e-mail to contact Motoman Customer Support, please provide a detailed description of your issue, along with complete contact information. Please allow approximately 24 to 36 hours for a response to your inquiry.



Please use e-mail for **routine** inquiries only. If you have an urgent or emergency need for service, replacement parts, or information, you must contact Motoman Customer Support at the telephone number shown above.

Please have the following information ready before you call:

- System
- Robots
- Positioner
- Primary Application
- Controller MLX200
- Software Version Access this information on the Teach Pendant's LCD display screen by selecting {MAIN MENU} - {SYSTEM INFO} - {VERSION}
- Robot Serial Number Located on the robot data plate
- Robot Sales Order Number Located on the controller data plate

## 3 Installation

### 3.1 Handling Procedure



#### CAUTION

- Avoid jarring, dropping, or hitting the drive panel during handling. Excessive vibration or impacting the MLX200 may adversely affect the performance of the MLX200.

#### 3.1.1 Moving the Drive Panel

The MLX200 drive panel weighs approximately 31 - 47 kg (68 - 104 lbs). Be sure movers are strong enough to handle this weight.

### 3.2 Installation Environment

The conditions listed below must be met before installing the MLX200:

- Ambient temperature must be -5 to +55°C (23 to 131°F) during operation, transportation and maintenance.
- Humidity must be low with no condensation (10~85%RH).
- It must be a place with little dirt, dust, or water.
- No flammable or corrosive liquids or gases, etc. in the area.
- Little jarring or potential for striking of the MLX200 (under 0.5g oscillation).
- No large electric noise source (such as a TIG welding device, etc.) nearby.
- No potential for collision with moving equipment such as forklifts.

### 3.3 Location

1. The MLX200 drive panel is designed to be installed in a suitable industrial cabinet located outside of the P-point maximum envelope of the manipulator (outside of the safeguarding.)

Fig. 3-1: Location of MLX200

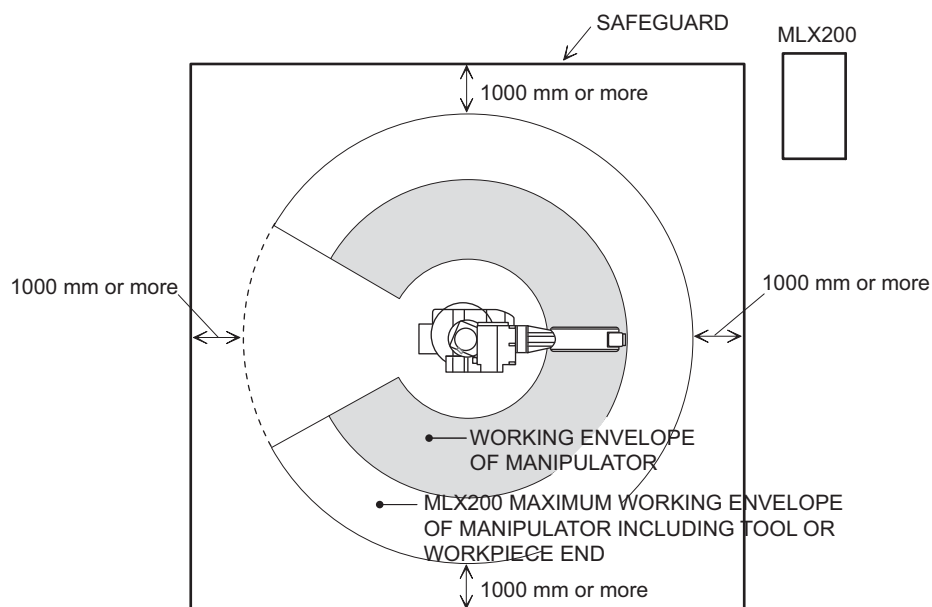

2. Install the drive panel in a location from which the manipulator is easily visible.
3. Install the drive panel in a location from which you can easily inspect it.
4. Install the drive panel at least 500 mm from the nearest wall to allow maintenance access.



Refer to the Instruction Manual for information on installation of the manipulator.

5. See Fig. 3-1 "Location of MLX200" on page 3-2 and Table 3-1 "MLX200 Drive Panel Dimensions (mm)" on page 3-3 for drive panel dimension requirements.

Fig. 3-2: MLX200 Drive Panel Dimensions

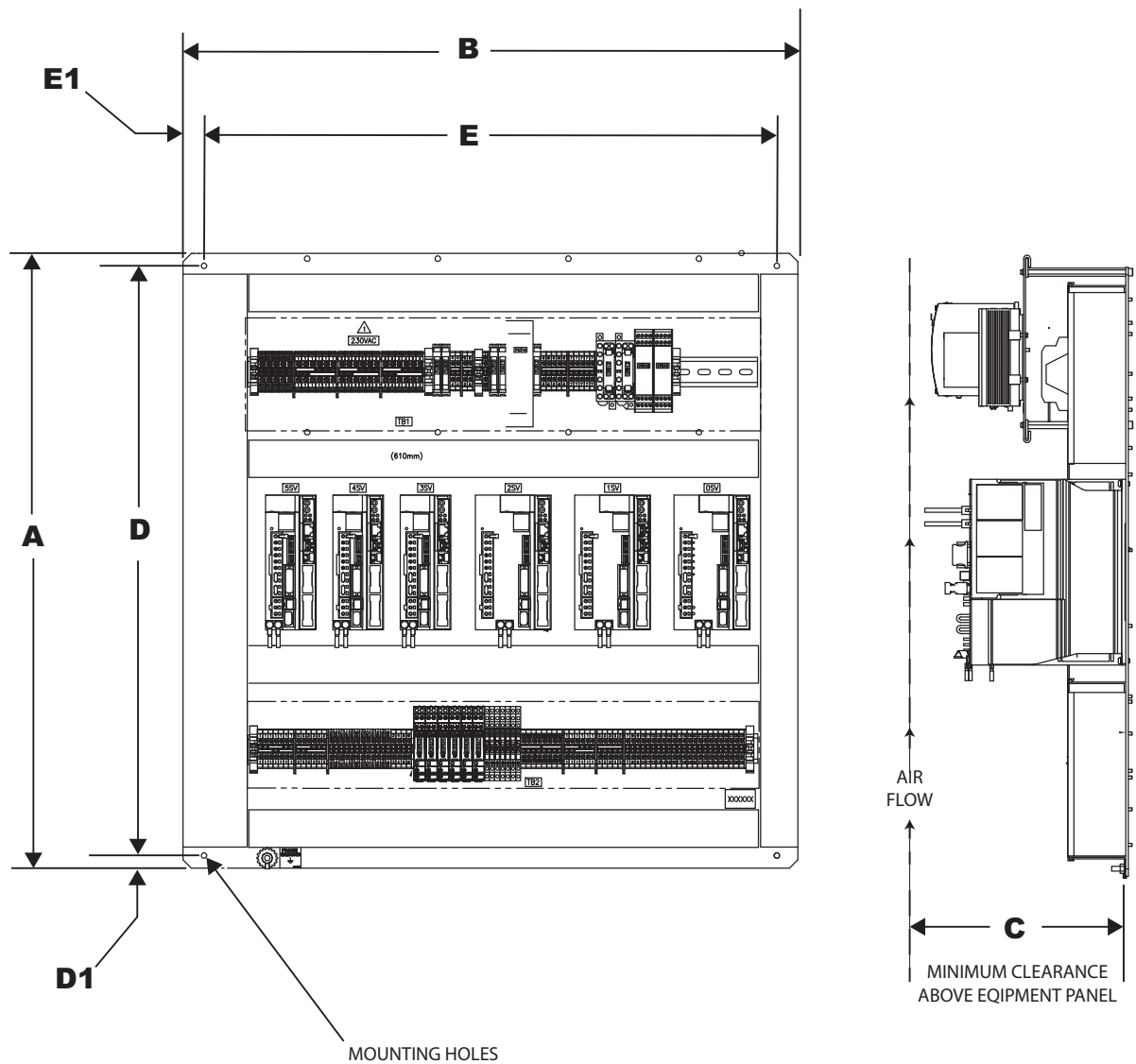

Table 3-1: MLX200 Drive Panel Dimensions (mm)

Manipulator	Drive Panel	Approximate Weight (kg)	A	B	C	D	D1	E	E1
MH5S, MH5LS, MH5S II, MH5LS II	159181-1	31	730	730	300	700	15	679	25
MH12	170094-1	33	730	730	300	700	15	680	25
HP20D	167761-1	33	730	730	300	700	15	680	25
MPK50	158547-1	41	820	655	300	790	15	605	25
MPL80, MPL80 II	159431-1	47	820	730	300	790	15	680	25
MPL160, MPL300	158546-1	43	820	655	300	790	15	605	25
MPL160 II, MPL300 II	173928-1	43	820	655	300	790	15	605	25

6. The customer supplied cabinet must be modified as appropriate to accept the drive panel pigtails for the manipulator and Regen cables. See Fig. 3-3(a), Fig. 3-3(b), Fig. 3-3(d) and Fig. 3-3(d).



Fig. 3-3(a): MPK50/ MPL80/ MPL80 II Pigtail Connections

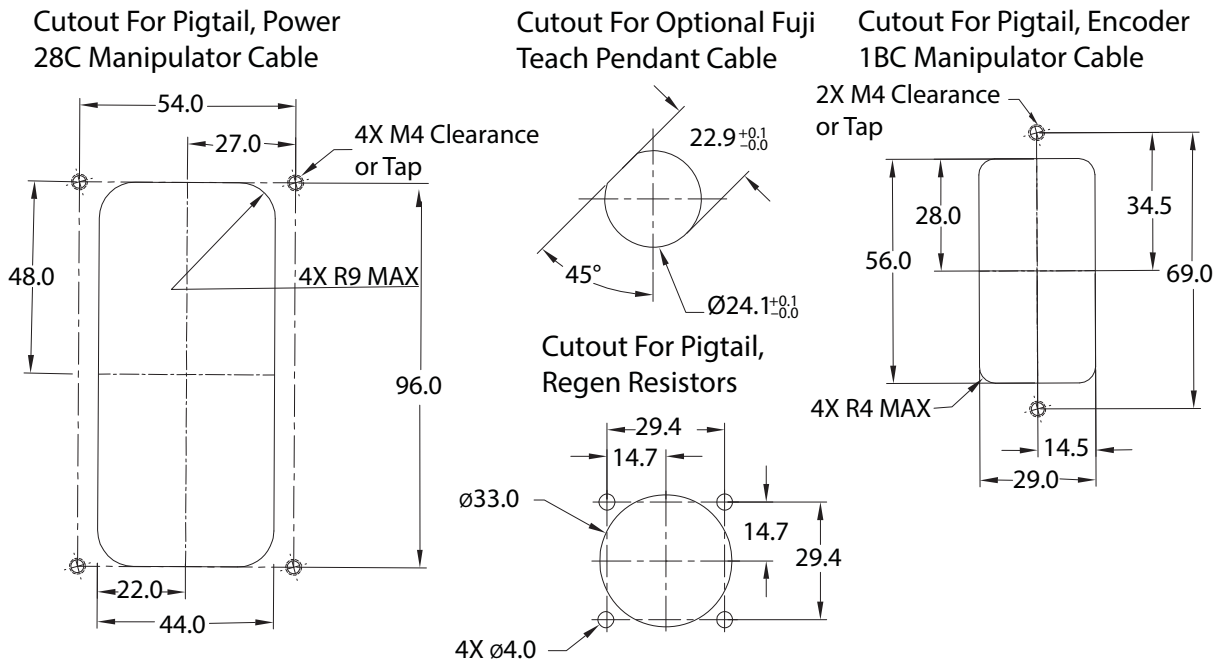

Fig. 3-3(b): MPL160/ MPL300 Pigtail Connections

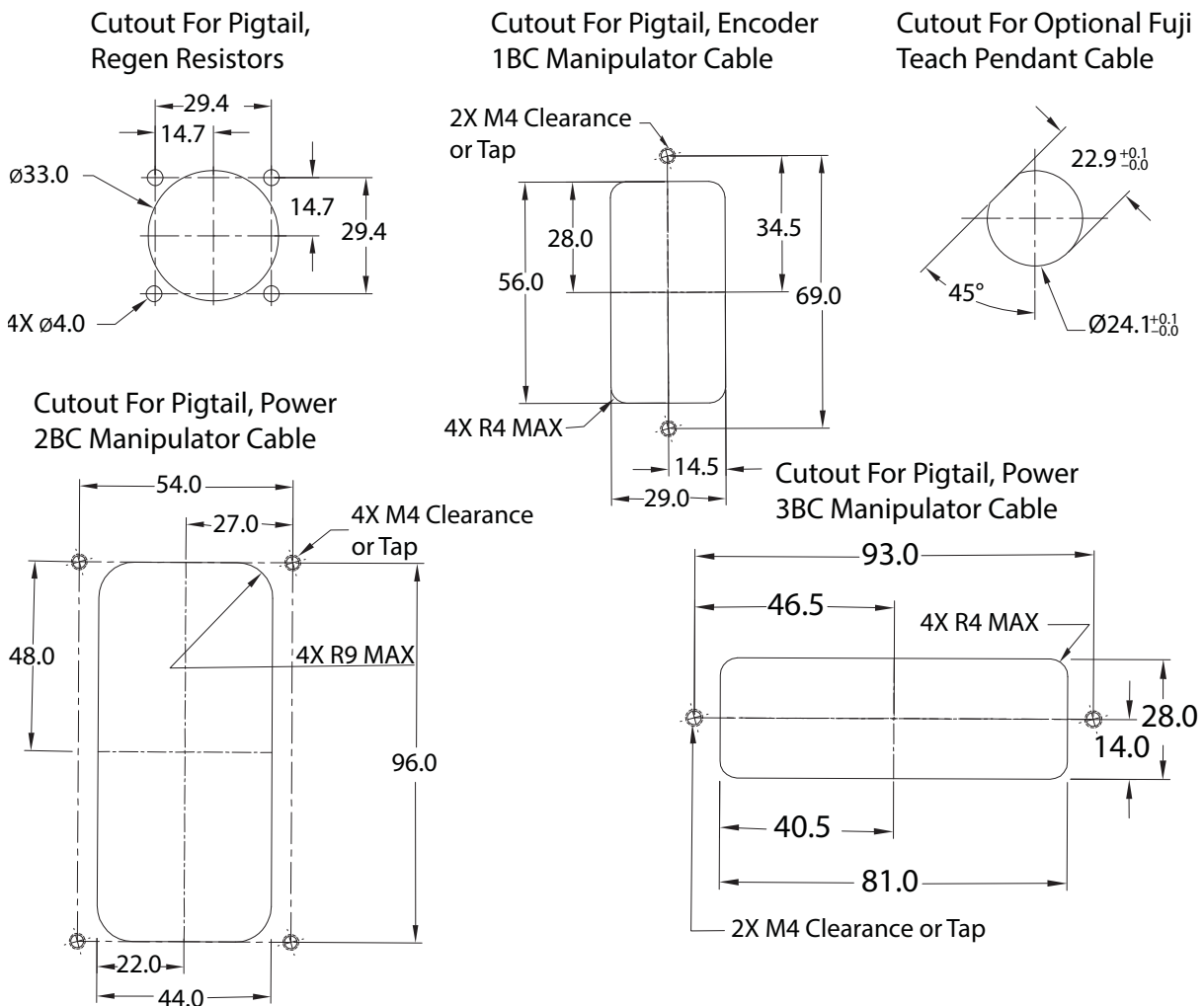

Fig. 3-3(c): MPL160 II/ MPL300 II Pigtail Connections

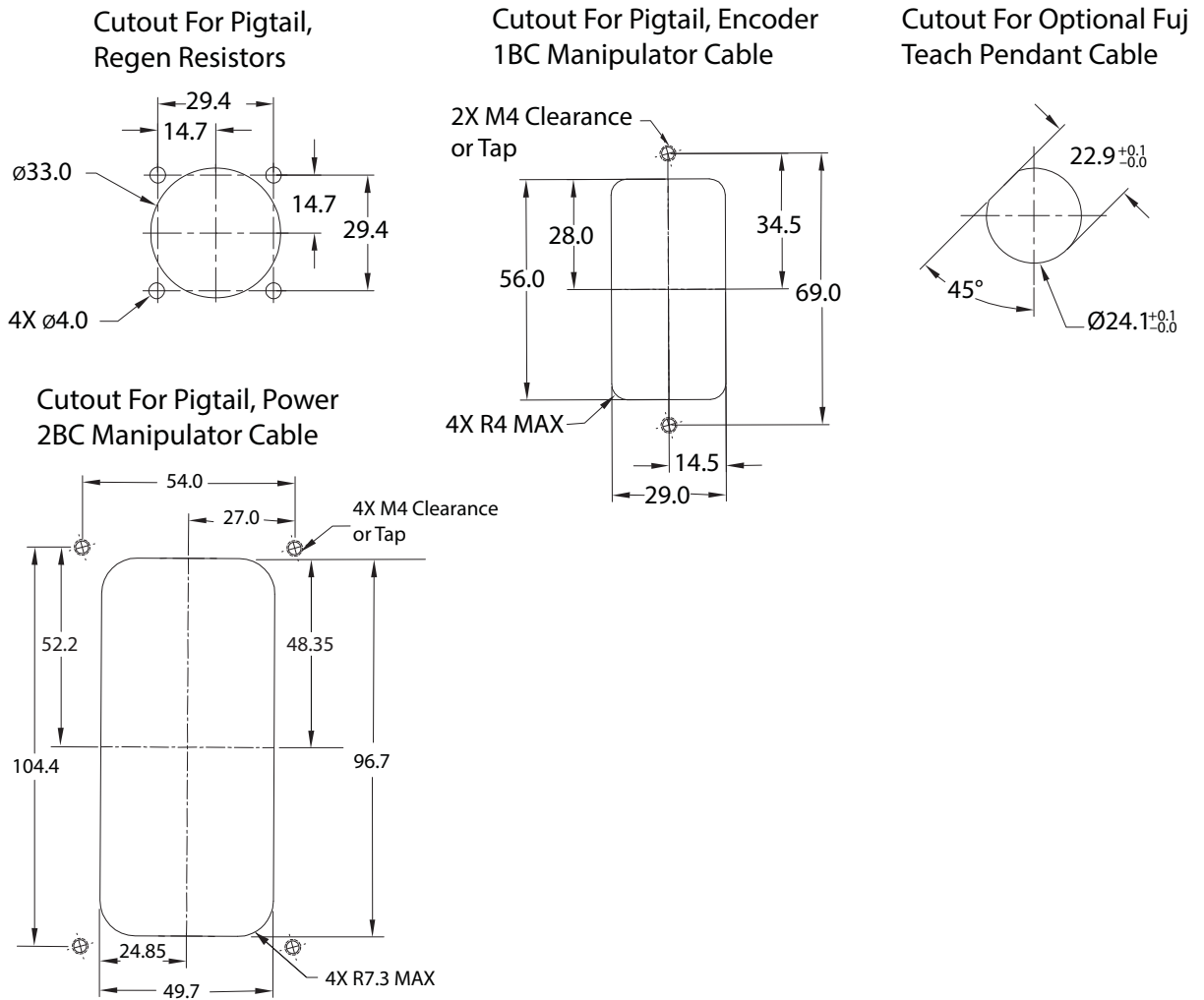

Fig. 3-3(d): MH5S/ MH5S II/ MH5LS/ MH5LS II Pigtail Connections

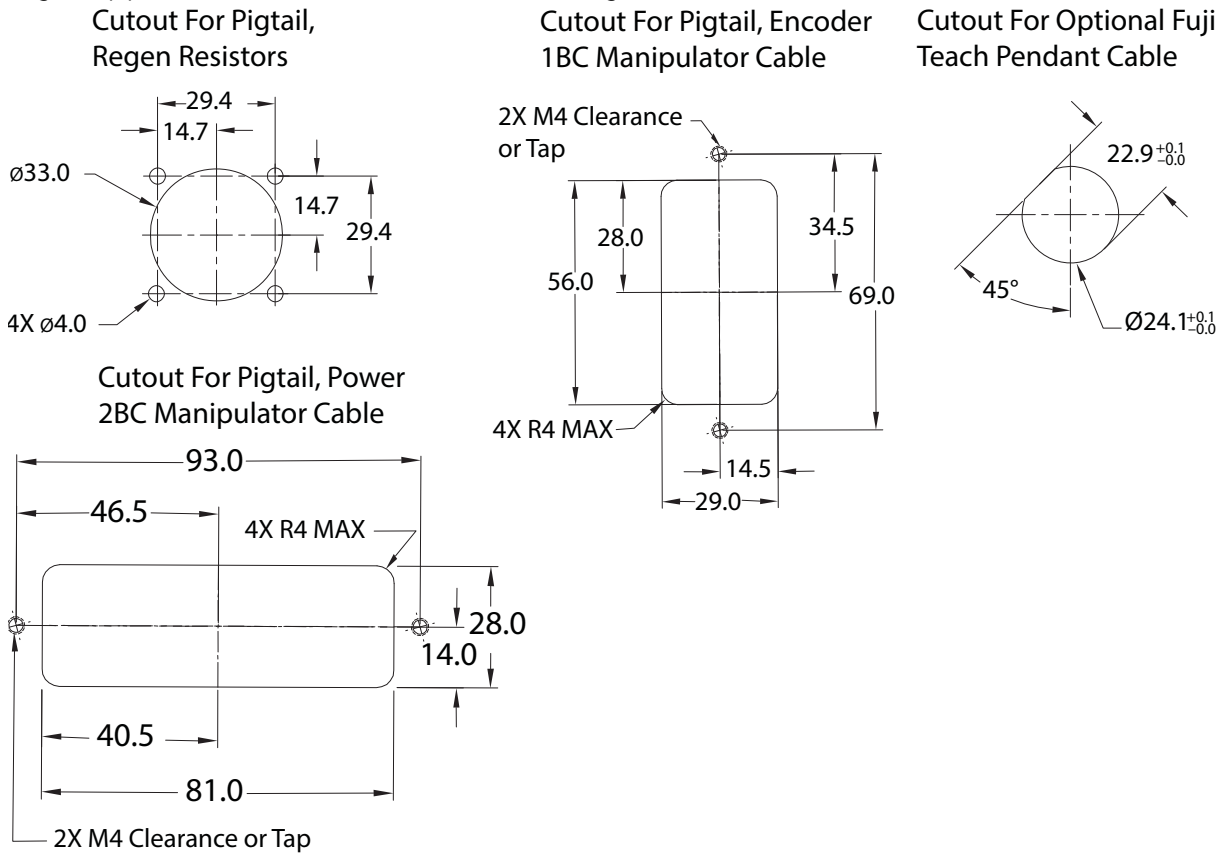
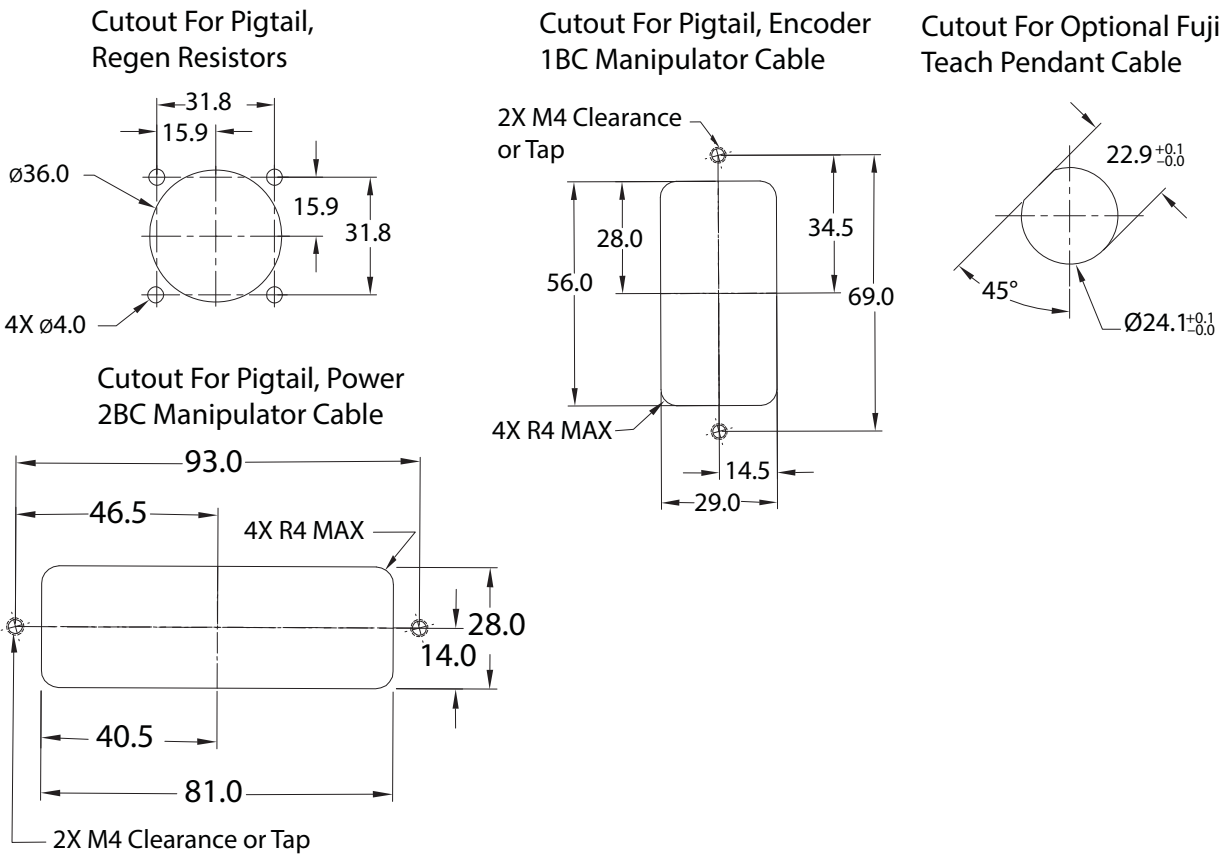
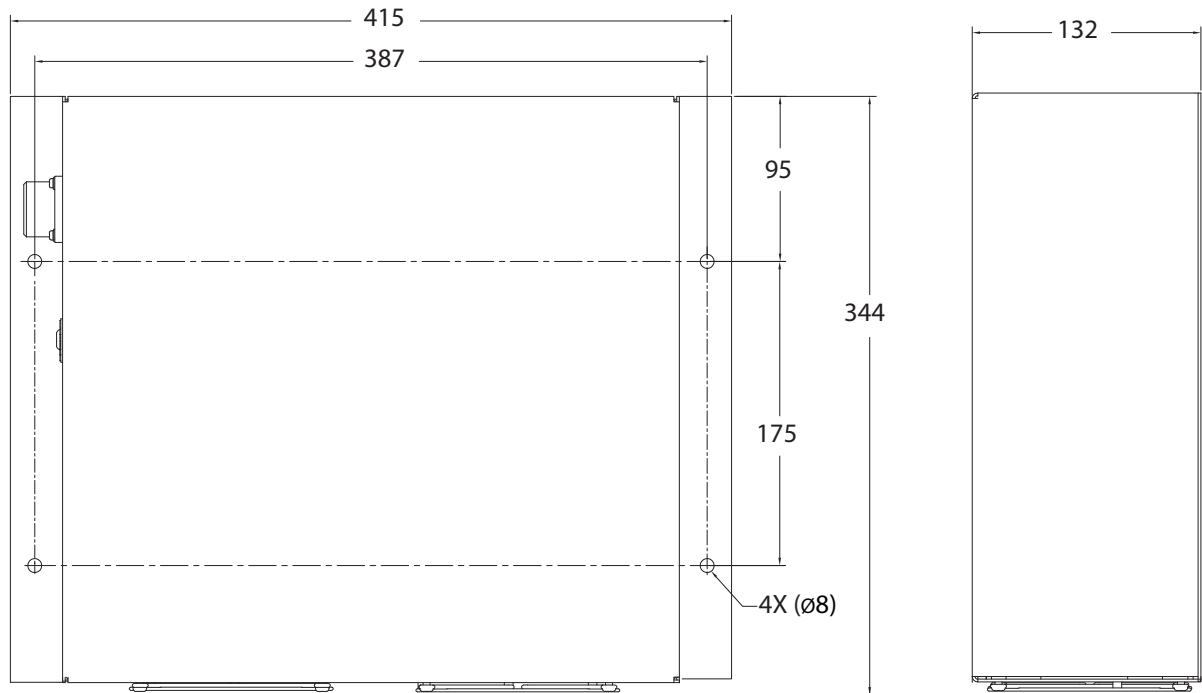

Fig. 3-4: MH12/ HP20D Pigtail Connections



7. The Regen cabinet may produce significant heat and should be mounted outside the main cabinet with the fans directed up. See *Fig. 3-5(a)* and *Fig. 3-5(b)*.

*Fig. 3-5(a): MH5S/ MH5S II/ MH5LS/ MH5LS II Regen Cabinet Mounting Dimensions and Weight*



Weight: 8 kg

Fig. 3-5(b): MH12, HP20D, MPK50, MPL80, MPL160, MPL300, MPL80 II, MPL160 II, MPL300 II,  
Regen Cabinet Mounting Dimensions and Weight

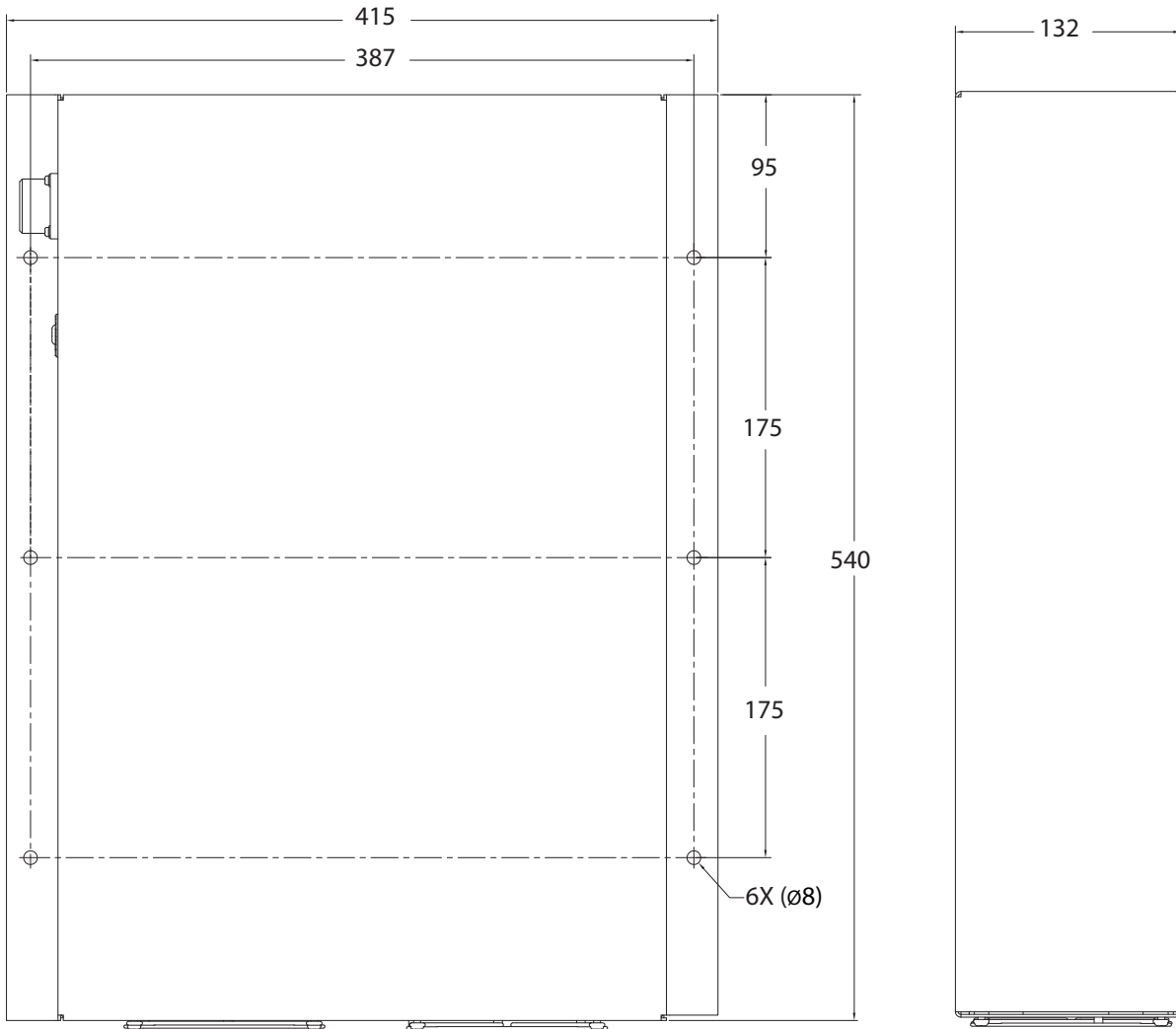

Weight: 13 kg

### 3.4 Cut-Outs for Emergency Stop and Auto/ Manual Buttons

Each MLX200 Master Control panel is supplied with one Emergency Stop button and one Auto/ Manual button that should be mounted to the enclosure for users to interact with. These buttons are wired using a cable with approximately four meters of length available between panel and buttons. Each button has a cut-out matching *Fig. 3-6* below.

*Fig. 3-6: Emergency Stop and Auto/ Manual Cut-Out*

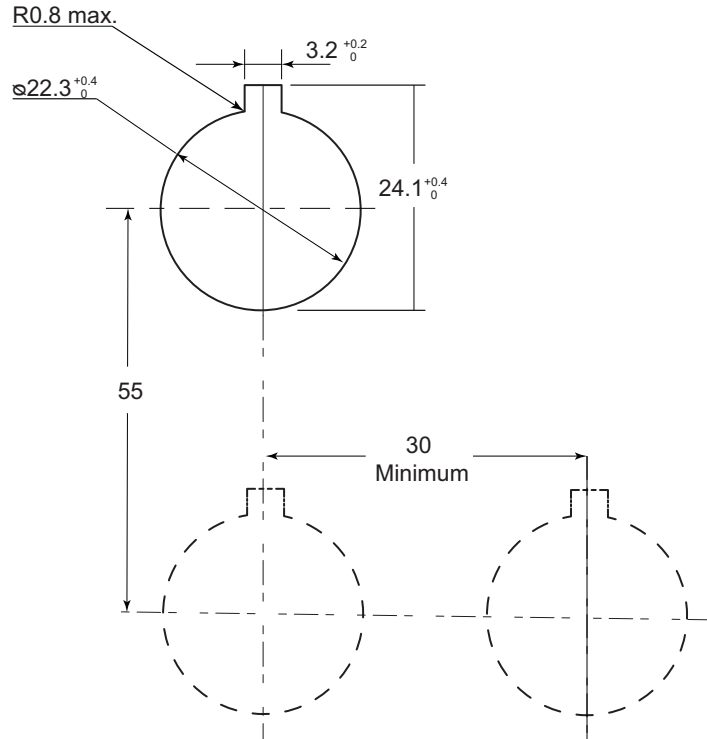

## 4 Connections



### WARNING

- The system must be grounded.  
Failure to ground equipment may result in injury from fire or electric shock.
- Before wiring, make sure to turn OFF the primary power supply, and put up a warning sign. (ex. DO NOT TURN THE POWER ON)  
Failure to observe this caution may result in injury and electric shock.
- Do not touch any board inside the drive panel for five minutes after turning OFF the power supply.  
Capacitors inside the drive panel store electricity after power is turned OFF. Exercise caution whenever handling circuit boards.  
Failure to observe this caution may cause electrical shock.
- Power cannot be turned ON unless the door is closed. Interlocks prevent power from being turned ON.  
Failure to observe this caution may result in fire and electric shock.
- Any occurrence during wiring while the MLX200 is in the emergency stop mode is the user's responsibility. Do an operation check once the wiring is completed.  
Failure to observe this caution could lead to injury or mechanical failure.



### CAUTION

- Wiring must be performed only by authorized personnel.  
Incorrect wiring may cause fire and electric shock.
- Perform wiring in accordance with the rated capacity as specified in the Instructions.  
Incorrect wiring may cause fire or mechanical breakdown.
- Be sure the power circuit screws are securely tightened.  
Loose power circuit wires can cause fire and electric shock.
- Do not handle the circuit board directly by hand.  
The IC board may malfunction due to electrostatics.

## 4.1 Notes on Cable Junctions

- The cables that connect the drive panel to peripheral device are low voltage circuits. Keep drive panel signal cables away from the primary power circuit. High voltage power lines should not be run in parallel to drive panel signal cables. If running parallel cables is unavoidable, use metal ducts or conduit to isolate electrical signal interference. If cables must be crossed, run the power cables perpendicular across the signal cables.
- Confirm the connector and cable numbers to prevent misconnection and equipment damage. One connects the manipulator and MLX200. Another connects the MLX200 and peripheral device. A wrong connection can cause damage to electronic equipment.
- Clear the area of all unauthorized personnel while making cable connections. Place all cables in a covered cable channel in the floor.

Fig. 4-1: MLX200 Cable Junction Diagram

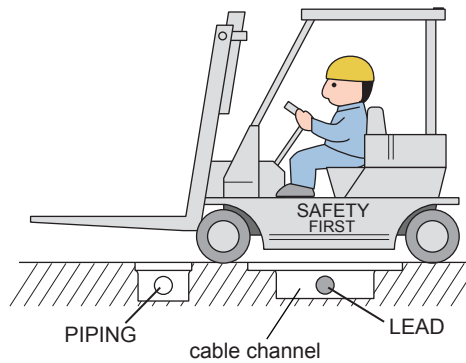



## 4.2 Power Supply

### 4.2.1 Three-Phase Power Supply

#### NOTE

The power failure processing circuit operates when there is a black out or drop in voltage, and the servo power turns OFF.

- Connect the power supply to a stable power source that is not prone to power fluctuations.

The three-phase power supply consists as follows:

- Without built-in transformer: 230 V<sub>AC</sub> at 50 Hz/ 60 Hz

### 4.2.2 Primary Power Supply Breaker/ Fuse Installation

#### NOTE

It is the customer's responsibility to provide adequate breaker/ fusing for their application.

Install the primary power supply breaker/ fuse as shown.

Fig. 4-2: Installation of the Primary Power Supply Breaker/ Fuse

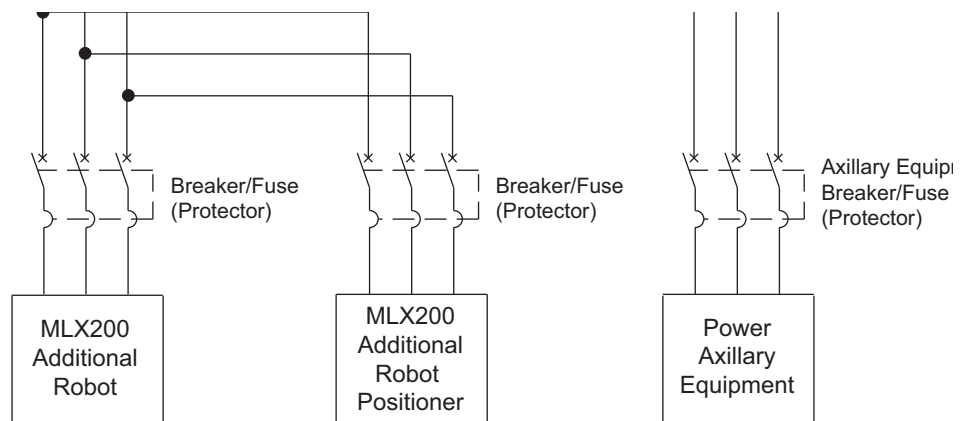

Table 4-1: MLX200 Power Capacity, Cable Sizes, and Breaker/ Fuse Capacities

Manipulator	Power Capacity (kVA)	Cable size (In case of Cabtyre cable (three cores)) (AWG)	Capacity of breaker/ fuse in MLX (A)
MH5S, MH5S II, MH5LS, MH5LS II	1	16	10
MH12	2.6	16	10
HP20D	2.5	16	10
MPK50	6.0	14	15
MPL80, MPL80 II	6.0	14	15
MPL160, MPL300, MPL160 II, MPL300 II	10.0	10	25

Select and utilize the breaker/ fuse with appropriate breaking capacity in consideration of the MLX200 panel power capacity for the manipulator to be used.

The maximum load value (payload, operation speed, and frequency, etc.) is displayed.

However, the power capacity is different depending on work conditions.

Inquire at the nearest branch office listed on the back cover for information when selecting the transformer.

### 4.3 Connection Methods

A connection diagram for the manipulator, manipulator cable, primary power cable and optional teach pendant is shown below.

Fig. 4-3: Single Robot Cable Connection

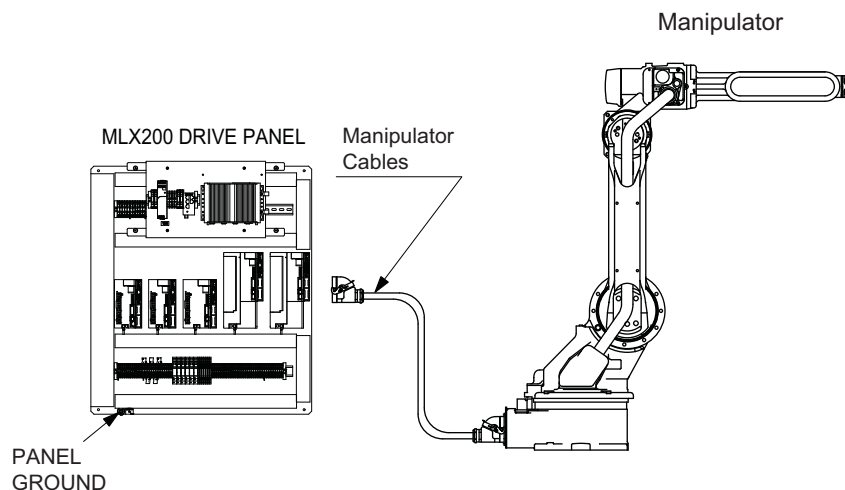

#### 4.3.1 Connecting the Primary Power Supply

1. Confirm that the primary power supply is OFF.
2. Run the primary power supply through fuses to TB1-1, TB1-2, and TB1-3. Connect a ground wire to reduce noise and prevent electric shock (Customer must provide fusing).

Perform grounding in accordance with all relevant local and national electrical codes. The size of ground wire must be the same as listed on *Table 4-1 "MLX200 Power Capacity, Cable Sizes, and Breaker/ Fuse Capacities"* on page 4-3.



The customer must prepare the ground wire.

Fig. 4-4: Exclusive Grounding

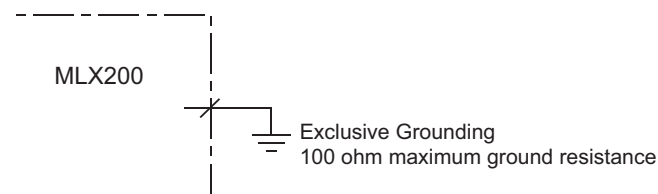

Don't connect the grounding wire with the wires for the electric power source, the welder, etc.

Ground in accordance with all relevant governmental regulations when using metallic ducts, metallic conduits, and cable tray to construct the cable.

### 4.3.2 Connecting the Manipulator Cable

1. Remove the package, and take out the manipulator cable. Connect the cable to the MLX200 connectors.

Fig. 4-5: Connection of the Manipulator Cable

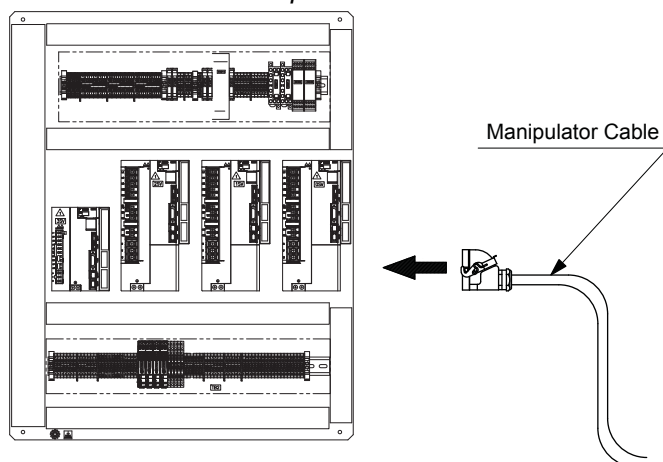

For more information on connecting the manipulator cable, please refer to the Instruction Manual which corresponds to the particular robot model.

2. Connect the manipulator to the MLX200.
  - Confirm the shape and size of the cable connector, the key fitting, and the position of the pins of the manipulator. Push the cable connector into the manipulator side connector firmly, and tighten securely.



## CAUTION

Always keep the MLX200 panel in an isolated enclosure.

If dust or water enter inside the drive panel, electric shock or breakdown of MLX200 may result.

**4.3.3 Dual Robot Connection**

If using a Dual Robot *Fig.4-6 Dual Robot Additional Robot Cable Connections* show the additional connections required. between the Master and slave Drive Panel

When using a dual robot the basic connections for the slave robot is the same as the first except;

- No MLX200 Control Module
- Make the interlock cable connections
- Connection from EtherCat from the last amp (SV(x)) on the master panel to the first amp (SV0) on slave panel.

*Fig. 4-6: Dual Robot Additional Robot Cable Connections*

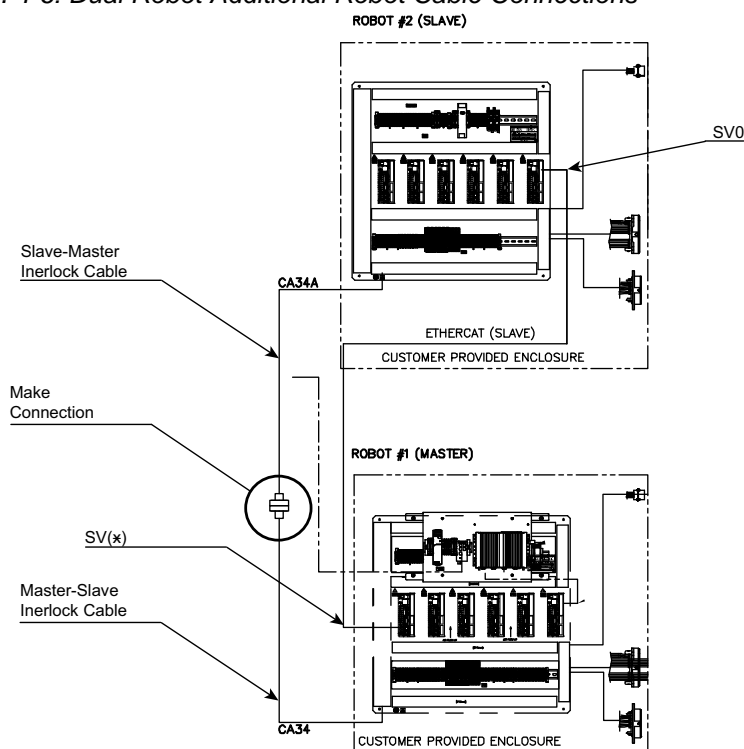

## 5 Turning ON and OFF the Power Supply

### 5.1 Turning ON the Main Power Supply

Confirm that nobody is present in the P-point maximum envelope of the manipulator when turning ON the MLX200 power supply. Failure to observe this caution could result in injury caused by accidental contact with the manipulator. Press an emergency stop button immediately if any problems occur.

The main power supply is turned ON when the customer prepared, 3-phase power supply is engaged.

### 5.2 Turning OFF the Power Supply

#### 5.2.1 Turning OFF the Servo Power (Emergency Stop)

The manipulator cannot be operated when an emergency stop button is pressed.

- Press the emergency stop button and the servo power supply is turned off.
- The brake operates once the servo power supply is turned OFF, and the manipulator can no longer operate. The emergency stop can be operated at any mode. (Teach mode, Play mode)



Typical Emergency Stop

## 6 Test of Program Operation



### WARNING

- Press an emergency stop button before operating the manipulator. Confirm that servo power is turned OFF.

Injury or damage to machinery may result if the manipulator cannot be stopped in case of an emergency.

- Observe the following precautions when performing teaching operations within the P-point maximum envelope of the manipulator:
  - Always view the manipulator from the front.
  - Always follow the predetermined operating procedure.
  - Always have an escape plan in mind in case the manipulator comes toward you unexpectedly.
  - Ensure that you have a place to retreat to in case of emergency.

Improper or unintentional manipulator operation can result in injury.

- Prior to performing the following operations, be sure that there is no one within the P-point maximum envelope of the manipulator, and be sure that you are in a safe place yourself.
  - Turning ON the MLX200 power
  - Moving the manipulator with the teach pendant
  - Running the system in the check mode
  - Performing automatic operations

Injury may result from collision with the manipulator to anyone entering the P-point maximum envelope of the manipulator.



### CAUTION

- Perform the following inspection procedures prior to performing teaching operations. If problems are found, correct them immediately, and be sure that all other necessary processing has been performed.
  - Check for problems in manipulator movement.
  - Check for damage to the insulation and sheathing of external wires.

## 6.1 Movement of the Axes

Move each axis of the manipulator by pressing the appropriate axis buttons on the MLX HMI.

The following figures illustrate each axis of motion in the joint coordinates.



Be sure to remove all items from the area before moving the manipulator.  
Refer to the INSTRUCTION MANUAL for the appropriate position of the fixture.

Fig. 6-1: 4-Axis Manipulator

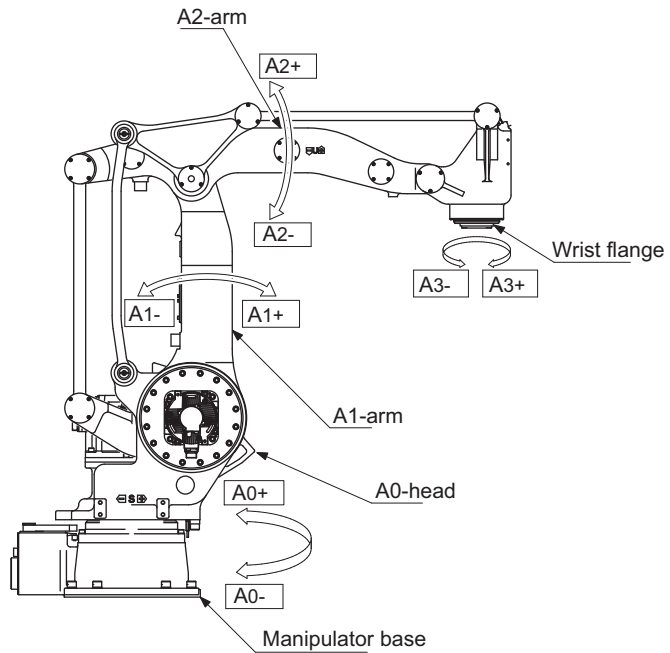



Fig. 6-2: 5-Axis Manipulator

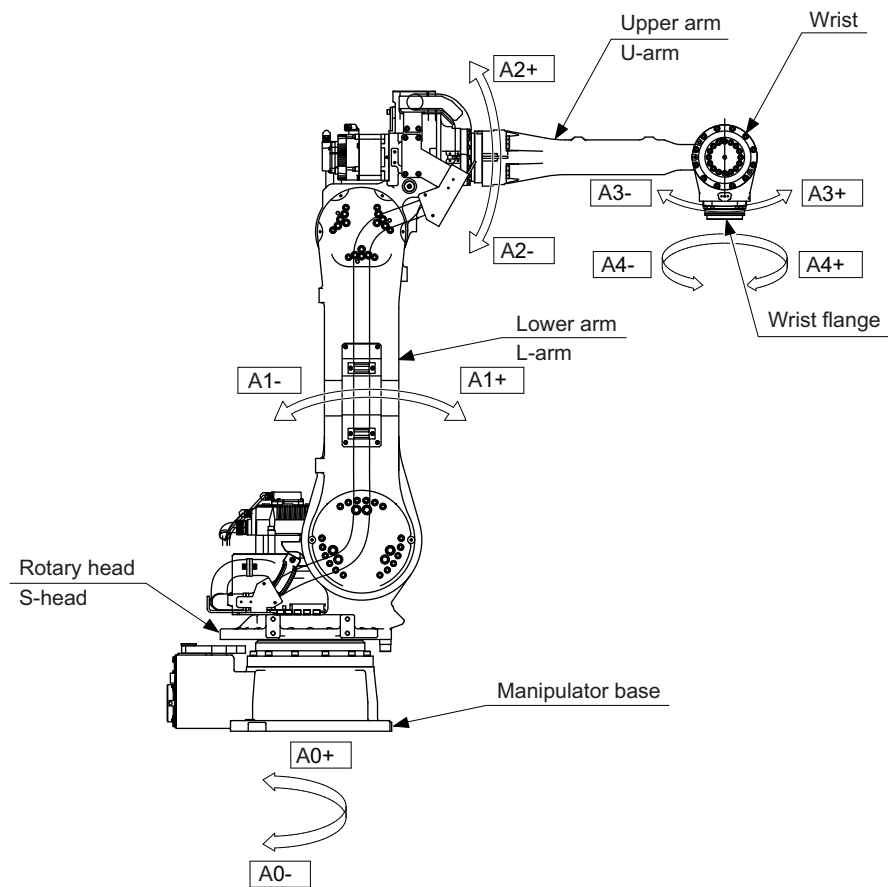

Fig. 6-3: 6-Axis Manipulator

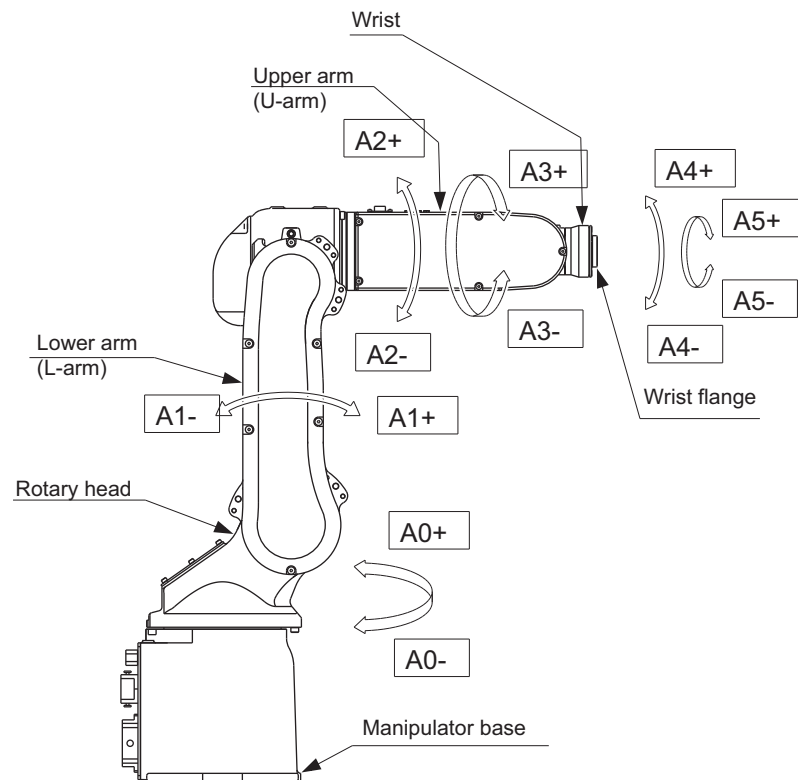
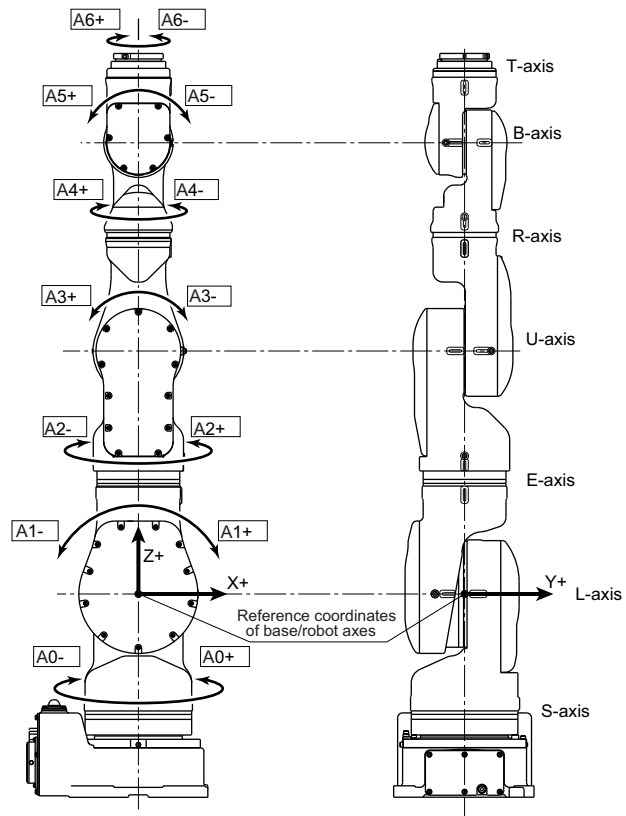

Fig. 6-4: 7-Axis Manipulator



## 7 System Setup



### WARNING

- Various settings control system compatibility and manipulator performance characteristics. Exercise caution when changing settings that can result in improper manipulator operation.

Personal injury and/ or equipment damage may result if incorrect settings are applied by the user.

- Observe the following precautions to safeguarding system settings:
- Maintain supervisory control of user functions.
- Retain data backups of control settings each time settings are changed.

### 7.1 Home Position Calibration



### WARNING

- Before operating the manipulator, check that the servo power turns OFF when the system emergency stop buttons are pressed.

Injury or damage to machinery may result if the manipulator cannot be stopped in case of an emergency.

- Observe the following precautions when performing teaching operations within the P-point maximum envelope of the manipulator:
  - View the manipulator from the front whenever possible.
  - Always follow the predetermined operating procedure.
  - Always prepare your reactions to a manipulator's unexpected approach toward you.
  - Ensure that you have a safe place to retreat in case of emergency.

Improper or unintended manipulator operation may result in injury.

- Prior to performing the following operations, be sure that no one is in the P-point maximum envelope of the manipulator, and be sure that you are in a safe place when:
  - Turning ON the MLX200 power.

Injury may result from contact with the manipulator if persons enter the P-point maximum envelope of the manipulator.

Always press an emergency stop button immediately if there are problems.

Emergency stop buttons should be located within easy access of the MLX200.



## CAUTION

- Perform the following inspection procedures prior to teaching the manipulator. If problems are found, correct them immediately, and be sure that all other necessary tasks have been performed.
  - Check for problems in manipulator movement.
  - Check for damage to the insulation and sheathing of external wires.

### 7.1.1 Home Position Calibration



Teaching and playback are not possible before the completion of the home position calibration.

In a system with two or more manipulators, the home position of all the manipulators must be calibrated before starting teaching or playback.

Home position calibration is an operation in which the home position and absolute encoder position coincide. Although this operation is performed prior to shipment at the factory, the following cases require this operation to be performed again.

- Change in the combination of the manipulator and MLX200 drive panel
- Replacement of the motor or absolute encoder
- Clearing stored memory (MLX200 Control Module, weak battery, etc.)
- Home position deviation caused by hitting the manipulator against a workpiece, etc.

To calibrate the home position, use the axis keys to calibrate the home position mark on each axis so that the manipulator can take its posture for the home position. There are two operations for home position calibration:

- Axes can be moved individually: Recalibrate the home position for the individual axes that were affected by the replacement, if replacing the motor or absolute encoder.

If the absolute data of its posture for the home position is already known, set the absolute data again after completing home position registration.

## 7.1.2 Calibrating Operation



Home position calibration can only be performed in management mode.

1. From the [Login] screen, enter User: “expert” and Password: “expert”. The main screen shows “EXPERT” when successful.
2. Press the [Menu] button and then select the [Teach Screen] button. The MLX200 - Teaching and Jogging screen appears.

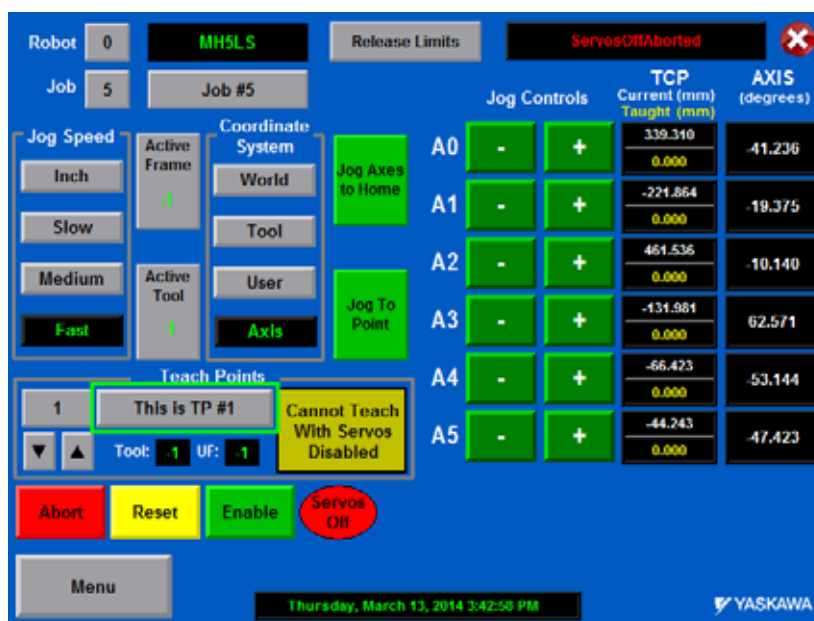

3. Set Jog Speed to “Inch” and Coordinate System to “Axis.”
4. Turn servo power ON by pressing [Reset], and then the [Enable Servos] button.

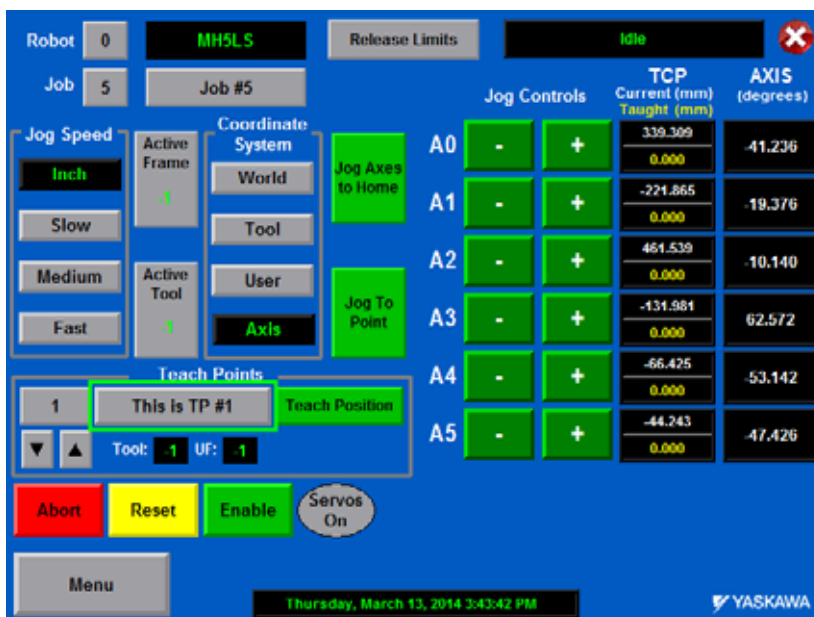

5. Jog the robot to its home position marks. Adjust the Jog Speed as required.
6. When in home position, press [MENU], then [Robot Configuration].

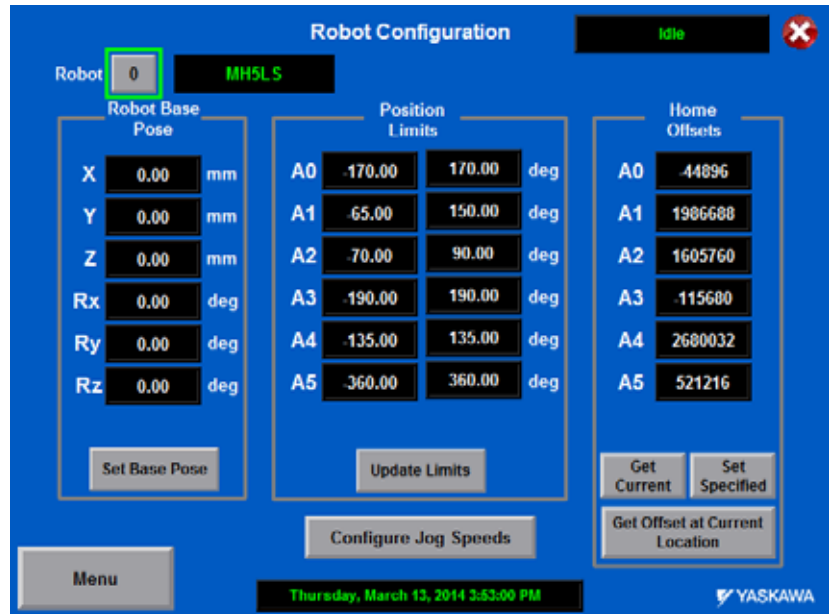

7. Establish the Home position. Press [Get Current]. The values update. *Alternative:* the home position values can also be read from a home position sticker located on the robot and entered into the "Home Offset" values. Then press [Set Specified].
8. Wait 10 seconds and press [Save Home Offsets].
  - Observe a WARNING appears.

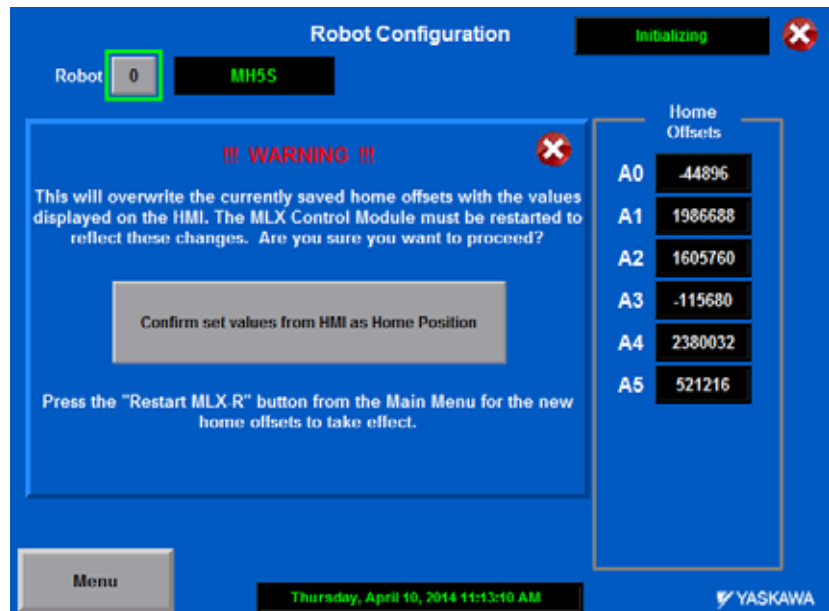

9. Confirm the set values from HMI as the Home Position on the !!WARNING!! pop-up screen. After pressing this button servos will shut off.

10. Wait five seconds then press [MENU] in the lower left and press the [Restart MLX-R] button.

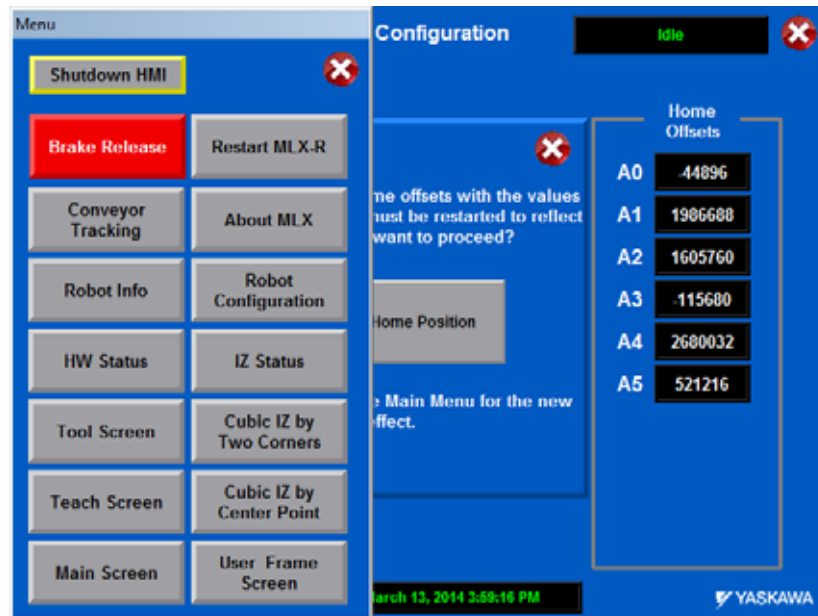

11. The robot is now homed. Many times the position will have to be "Verified" because of the change of home position. Do this from the main screen using the green button available.



When communication is re-established, the Axis Position list values should be close to zero. The robot may have drifted slightly at servo off. It should take 20 to 30 seconds for the MLX200 Robot Control Module to return to active communication.

- "MLX Module Connected" indicator will show ON/ green
- "MLX Module Initialized" indicator will show ON/ green

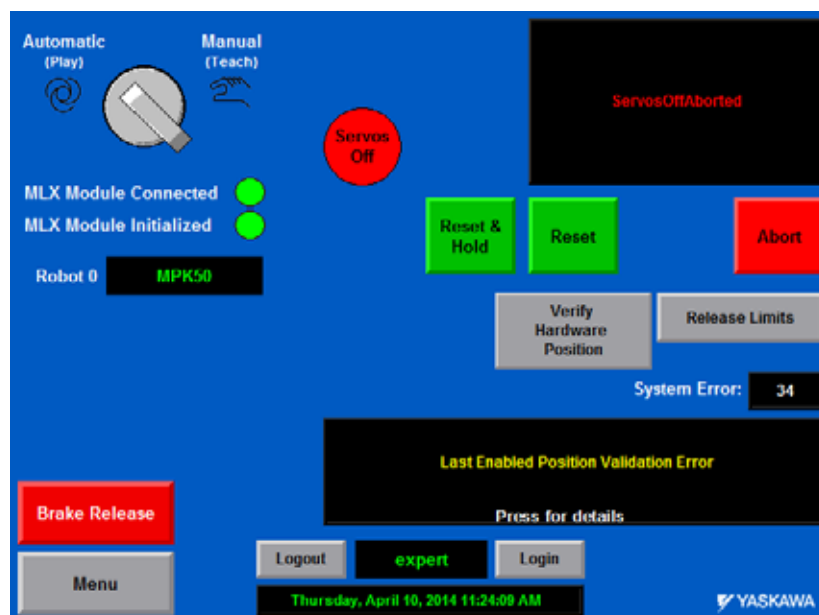

**7.1.3 Home Position of the Robot**

In case of MH5S, the home position are as follows.

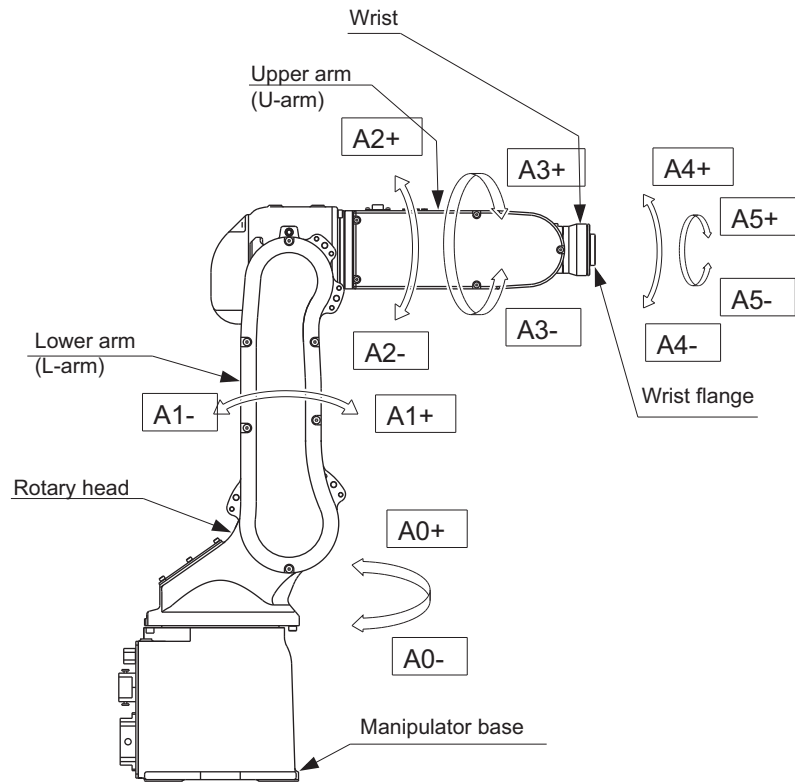

Other manipulator models have different positions. Always refer to “MANIPULATOR INSTRUCTIONS” for the correct manipulator model.



#### 7.1.4 Purpose of Position Check Operation

If the absolute number of rotation detected at power supply ON does not match the data stored in the absolute encoder the last time the power supply was turned OFF, an alarm is issued when the drive panel power is turned ON.

There are two possible causes of this alarm:

- Error in the encoder system
- The manipulator was moved after the power supply was turned OFF.

If there is an error with the encoder system, the manipulator may stall when playback is started. If the absolute data allowable range error alarm has occurred, playback and test runs will not function and the position must be checked.

#### 7.1.5 Procedure after the Alarm



### WARNING

- Be aware of safety hazards when performing the position confirmation of the specified point.

Abnormality of the encoder system may be the cause of the alarm. The manipulator may operate in an unexpected manner, and there is a risk of damage to equipment or injury to personnel.

## 7.2 Tool Data Setting

### 7.2.1 Registering Tools

#### 7.2.1.1 Number of Tools

There are 24 tool files numbered 0 to 23.

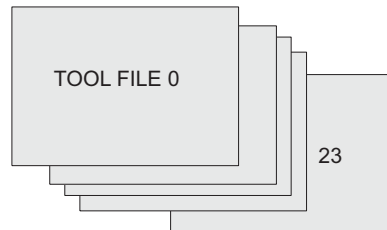

#### 7.2.1.2 Registering Coordinate Data

When the number input operation is used for registering the tool file, input the TCP of the tool on the flange coordinates.

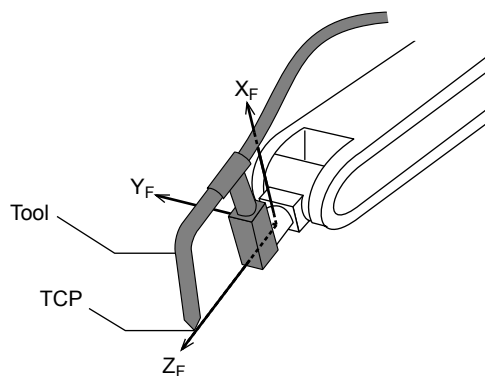

1. From the Teach screen, select [Active Tool] or go to the main [Menu] and select [Tool Screen].

- The system must be in Teach mode with all errors cleared before adjustments can be made to Tool Data. The message "Switch to TEACH mode to set" appears if the system is left in Play mode.

Fig. 7-1: Setup Tool Properties

- While in Teach Mode, press the tool number to select the Tool Number and modify. Press the Return key after the tool number is entered.
- Click the box to the right of the tool number to enter a text description.
- Enter the tool data following the examples shown below in Tool A and Tool B:

Fig. 7-2: Tool A

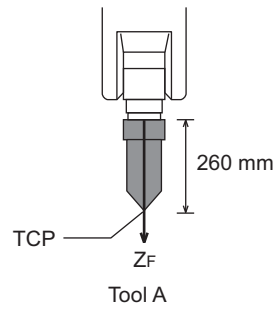
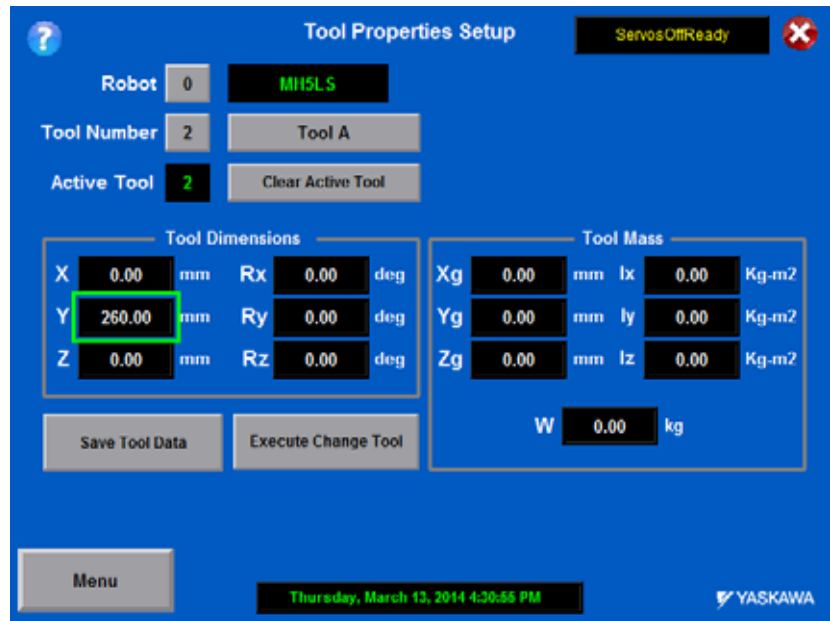

Fig. 7-3: Tool B

**Tool Properties Setup** ServosOffReady

Robot: 0 **MH5LS**

Tool Number: 3 **Tool B**

Active Tool: 3 **Clear Active Tool**

Tool Dimensions				Tool Mass							
X	0.00	mm	Rx	0.00	deg	Xg	0.00	mm	Ix	0.00	Kg-m <sup>2</sup>
Y	145.00	mm	Ry	0.00	deg	Yg	0.00	mm	Iy	0.00	Kg-m <sup>2</sup>
Z	260.00	mm	Rz	0.00	deg	Zg	0.00	mm	Iz	0.00	Kg-m <sup>2</sup>
						W	0.00	kg			

**Save Tool Data** **Execute Change Tool**

**Menu** Thursday, March 13, 2014 4:32:23 PM **YASKAWA**

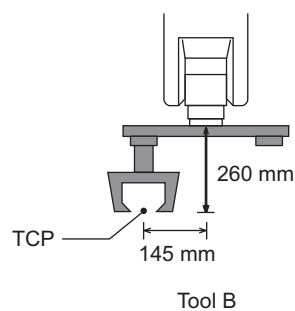

- Click the [Save Tool Data] button to store the modified tool information.



Tool data is not saved to the MLX200 Control Module until the [Save Tool Data] button is clicked. If data is incorrectly modified, simply close this screen and no changes will be made to the tool data. Similarly, changes are not retained until the [Save Tool Data] button is clicked.

7. Click on the [Execute Change Tool] button to have the robot use this tool when moving in the Tool Coordinate system. The tool appears as the active tool on the Teach screen.

Fig. 7-4: Active Tool Frame - Tool B is Set

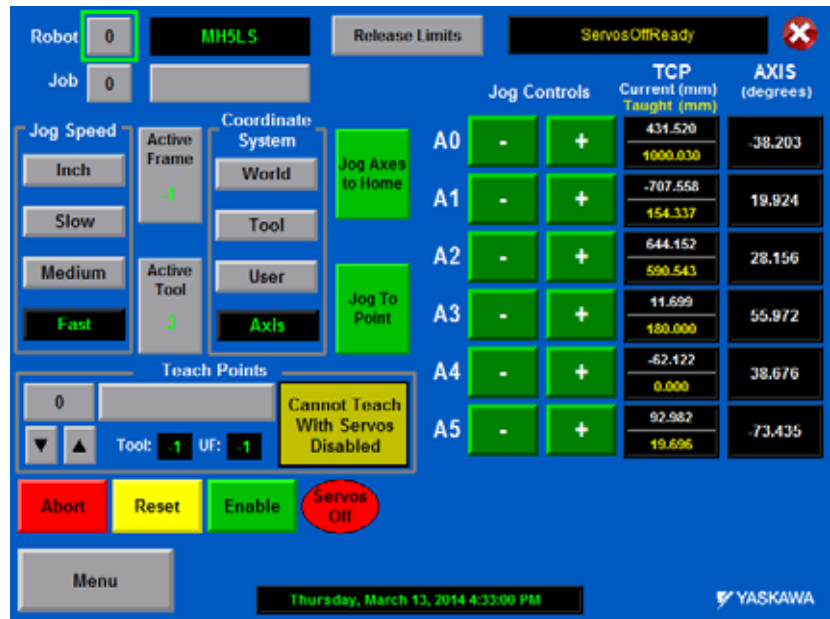

8. The active tool can also be changed by entering the [Active Tool] button.

7.2.1.3 Registering Tool Angle

The tool pose data is angle data which shows the relation between the flange coordinates and the tool coordinates. The angle when the flange coordinates are rotated to meet to the tool coordinates becomes an input value. Clockwise toward the arrow is the positive direction.

In the following case, register  $Rz=180$ ,  $Ry=90$ ,  $Rx=0$

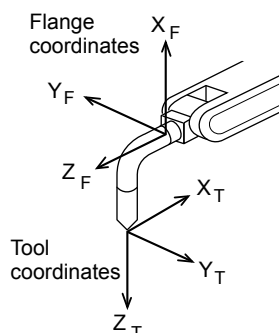

– Input rotation angle around  $Z_F$  of the flange coordinates.

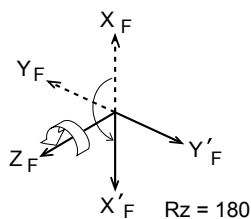

Ry must be the input rotation angle around Y''<sub>F</sub> flange coordinates.

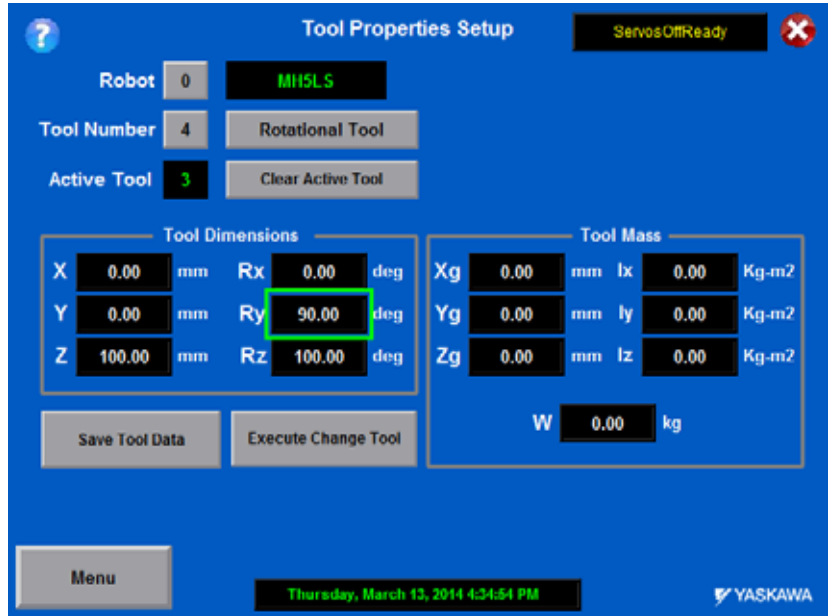
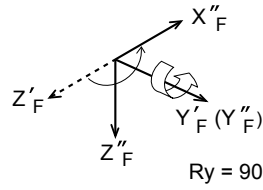

- Rx must be the input rotation angle around X''<sub>F</sub> of flange coordinates.

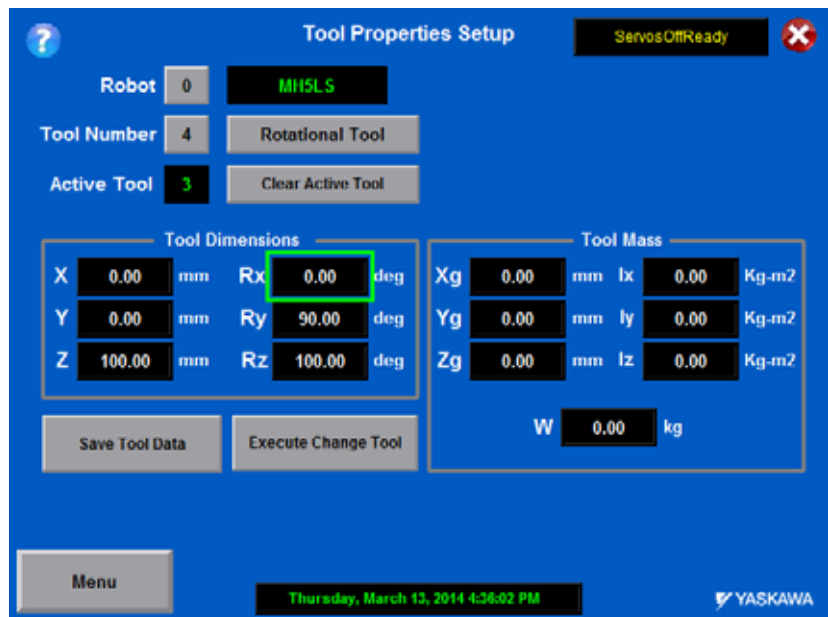
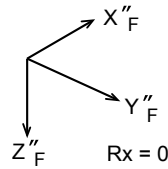



## 7.2.1.4 Setting the Tool Load Information

The tool load information includes weight, a center of gravity position, and moment of inertia at the center of gravity of the tool installed at the flange.

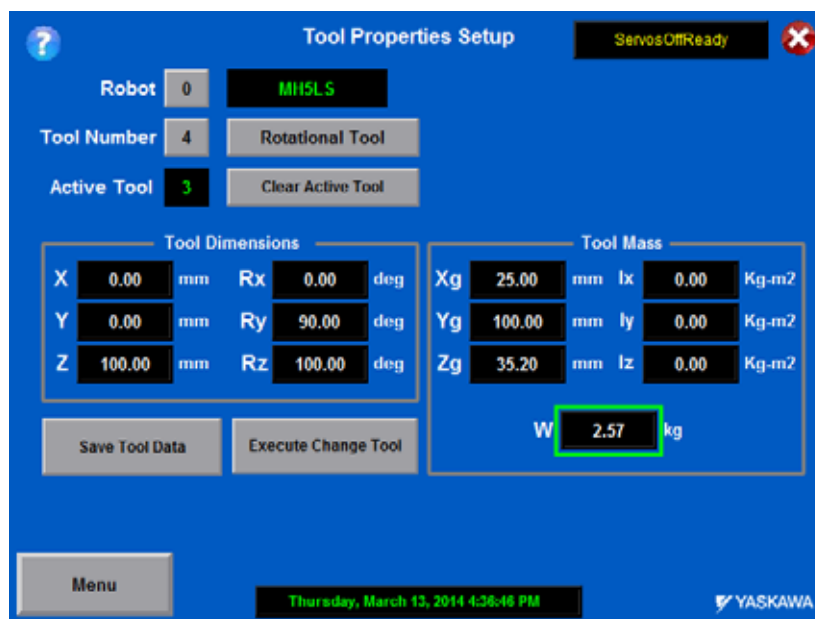

## 7.2.2 Tool Calibration

To ensure that the manipulator can perform motion type operations such as linear and circular motion types correctly, accurate dimensional information on tools such as torches, tools, and guns must be registered and the position of the TCP must be defined.

Tool calibration is a function that enables this dimensional information to be registered easily and accurately. When this function is used, the TCP is automatically calculated and registered in the tool file.

What is registered in tool calibration is the coordinates of the TCP and the tool posture data in the flange coordinates.

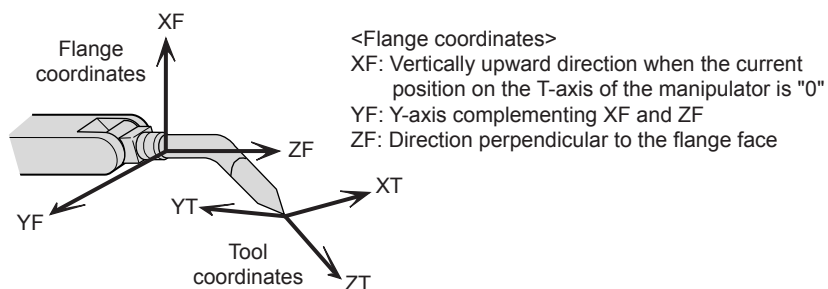

## 7.2.2.1 Checking the TCP

After registering the tool file, check if the TCP is correctly registered by performing a TCP fixed operation like the one shown below, in any coordinate system other than the joint.

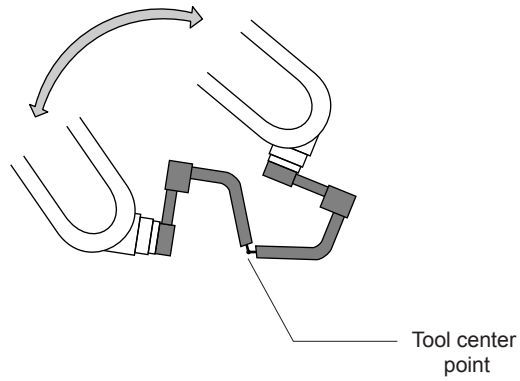

## 1. Move the R, B, or T axes using the axis key.

- By pressing the axis keys for the A3, A4, and A5 axes, change the manipulator pose without changing the TCP position.  
If this operation shows a large TCP error, adjust the tool data.

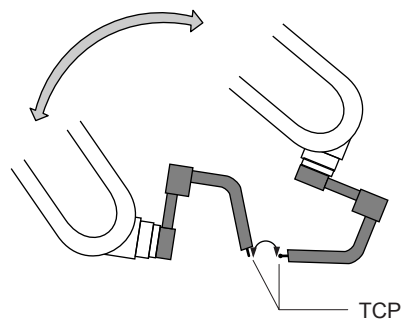

## 8 MLX200 Specification



### WARNING

- When turning ON the power to MLX200 Control Module, be sure that there is no one within the P-point maximum envelope of the manipulator, and that you are in a safe place.

Injury may result from collision with the manipulator to anyone entering the P-point maximum envelope of the manipulator. Always press the emergency stop button immediately if there are problems.

- Always set the teach lock before starting teaching.
- Observe the following precautions when performing teaching operations within the P-point maximum envelope of the manipulator:
  - View the manipulator from the front whenever possible.
  - Always follow the predetermined operating procedure.
  - Always have an escape plan in mind in case the manipulator comes toward you unexpectedly.
  - Ensure that you have a place to retreat to in case of emergency.

Improper or unintentional manipulator operation can result in injury.

- Before operating the manipulator, check that servo power is removed when an emergency stop button is pressed.

Injury or damage to machinery may result if the manipulator cannot be stopped in case of an emergency.



### CAUTION

- Perform the following inspection procedures prior to performing teaching operations. If problems are found, correct them immediately, and be sure that all other necessary processing has been performed.
  - Check for problems in manipulator movement.
  - Check for damage to the insulation and sheathing of external wires.

## 8.1 Specification List

<b>Drive Panel</b>	<b>Construction</b>	Free-standing, open sub panel
	<b>Dimensions</b>	Refer to following
	<b>Cooling System</b>	Indirect cooling
	<b>Ambient Temperature</b>	-5°C to + 55°C (During operation) -5°C to + 55°C (During transit and storage)
	<b>Relative Humidity</b>	10% to 85%RH (non-condensing)
	<b>Power Supply (24 VDC)</b>	Allen Bradley
	<b>Grounding</b>	Grounding resistance: 100Ω or less Exclusive grounding
	<b>Digital I/O</b>	- None provided - Add in via PLC modules
	<b>Positioning System</b>	By serial communication (absolute encoder)
	<b>Drive Unit</b>	SERVOPACK for AC servomotors
	<b>Acceleration/ Deceleration</b>	Software servo control
	<b>Memory Capacity</b>	PLC processor dependent

### 8.1.1 Panel Heat Loss (Estimate)

Table 8-1 "Total Amplifier Power Loss" does not include heat from the external regenerative resistor unit.

Table 8-1: Total Amplifier Power Loss

<b>Model Type</b>	<b>Power Loss [Watts (W)]</b>
MH5S, MH5S II, MH5LS, MH5LS II	196
MH12	308
HP20D	368
MPK50	1049
MPL80, MPL80 II	961
MPL160, MPL160 II MPL300, MPL300 II	1130

## 8.2 Equipment Configuration

The MLX200 drive panel is comprised of individual units and modules. Malfunctioning components can generally be easily repaired after a failure by replacing a unit or a module.

This section explains the configuration of the MLX200 equipment.

### 8.2.1 Arrangement of Units and Circuit Boards

The arrangements of units and circuit boards in one robot model is shown. Other robot models follow a similar layout.

#### ■ Small Capacity

*Fig. 8-1: Configuration - MPL80 Shown*

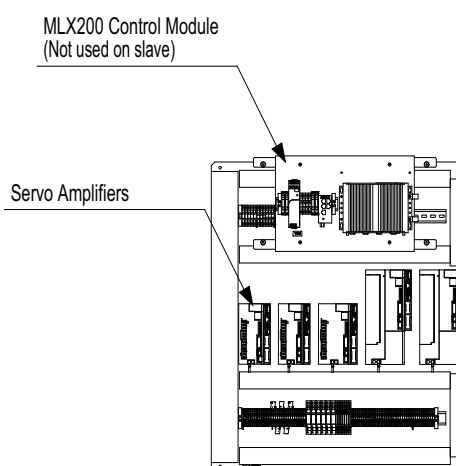

*Table 8-2(a): MLX200 Parts*

Description	MH5S	MH5LS	MH5S II	MH5LS II
MLX200 Robot Package	168360-*	168428-*	172221-1	171805-*
MLX200 Control Panel	159181-1	159181-1	159181-1	159181-1
Robot Manipulator	160427-5	160741-5	172178-1	170922-1
Manipulator 1BC Cable Length, 5M	155685-2	155685-2	166312-2	166312-2
Manipulator 2BC Cable Length, 5M	155686-2	155686-2	166313-2	166313-2
Manipulator 3BC Cable Length, 5M	N/A	N/A	NA	N/A
Regen Resistor Unit	160268-1	160268-1	160268-1	160268-1
Cable, Regen Resistor Unit, 1M	159081-1	159081-1	159081-1	159081-1
MLX200 Control Module	167522-1	167522-1	167522-1	167522-1

Table 8-2(b): MLX200 Parts (Continued)

Description	MH12	HP20D	MPL80	MPL80 II
MLX200 Robot Package	170146-*	168840-*	168361-*	174744-1
MLX200 Control Panel	170094-*	167761-*	159431-1	159431-1
Robot Manipulator	166525-3	155500-9	155778-5	170870-1
Manipulator 1BC Cable Length, 5M	166312-2	157325-2	155685-2	166312-2
Manipulator 2BC Cable Length, 5M	166313-2	155686-2	155688-2	166314-2
Manipulator 3BC Cable Length, 5M	N/A	N/A	N/A	N/A
Regen Resistor Unit	168724-1	168724-1	159036-3	159036-3
Cable, Regen Resistor Unit, 1M	168728-1	168728-1	159081-1	159081-1
MLX200 Control Module	167522-1	167522-1	167522-1	167522-1

Table 8-2(c): MLX200 Parts (Continued)

Description	MPL160	MPL160 II	MPL300	MPL300 II
MLX200 Robot Package	167760-*	173930-1	168534-*	173931-*
MLX200 Control Panel	158546-1	173928-1	158546-1	173928-1
Robot Manipulator	158466-1	170920-1	159473-1	171742-1
Manipulator 1BC Cable Length, 5M	155685-2	166312-2	155685-2	166312-2
Manipulator 2BC Cable Length, 5M	151482-2	165546-2	151482-2	166546-2
Manipulator 3BC Cable Length, 5M	156874-2	N/A	156874-2	N/A
Regen Resistor Unit	159036-2	159036-2	159036-2	159036-2
Cable, Regen Resistor Unit, 1M	159081-1	159081-1	159081-1	159081-1
MLX200 Control Module	167522-1	167522-1	167522-1	167522-1

Table 8-3: Configuration

Model Type		S	L	U	R	B	T
MH5S	MLX200 AXIS NAME	SV0	SV1	SV2	SV3	SV4	SV5
MH5S II	SERVO AMPLIFIER	157430-5	157430-5	157430-5	157430-10	157430-10	157430-10
MH5LS	REGEN RESISTOR	143138-3	143138-3	143138-3	N/A	N/A	N/A
MH5LS II							
MH12	MLX200 AXIS NAME	SV0	SV1	SV2	SV3	SV4	SV5
	SERVO AMPLIFIER	157430-6	157430-7	157430-1	157430-5	157430-5	157430-5
	REGEN RESISTOR	143138-2	143138-2	143138-2	143138-3	143138-3	143138-3
HP20D	MLX200 AXIS NAME	SV0	SV1	SV2	SV3	SV4	SV5
	SERVO AMPLIFIER	157430-6	157430-7	157430-1	157430-5	157430-5	157430-5
	REGEN RESISTOR	143138-2	143138-2	143138-2	143138-3	143138-3	143138-3
MPK50	MLX200 AXIS NAME	SV0	SV1	SV2			SV3
	SERVO AMPLIFIER	157430-9	157430-9	157430-9			157430-2
	REGEN RESISTOR	143137-1	143137-1	143137-1			143138-2
MPL80	MLX200 NAME	SV0	SV1	SV2		SV3	SV4
MPL80 II	SERVO AMP	157430-9	157430-9	157430-11		157430-6	157430-6
	REGEN RESISTOR	143137-1	143137-1	143138-1		NA	143138-2
MPL160	MLX200 AXIS NAME	SV0	SV1	SV2			SV3
MPL160 II	SERVO AMPLIFIER	157430-9	157430-9	157430-9			157430-11
MPL300	REGEN RESISTOR	143137-1	143137-1	143137-1			143138-1
MPL300 II							

## 9 Description of Units and Circuit Boards



### WARNING

- When turning ON the power to MLX200, be sure that there is no one within the P-point maximum envelope of the manipulator, and that you are in a safe place.

Injury may result from collision with the manipulator to anyone entering the P-point maximum envelope of the manipulator. Always press the emergency stop button immediately if there are problems.

- Always set the teach lock before starting teaching.
- Observe the following precautions when performing teaching operations within the P-point maximum envelope of the manipulator:
  - View the manipulator from the front whenever possible.
  - Always follow the predetermined operating procedure.
  - Always have an escape plan in mind in case the manipulator comes toward you unexpectedly.
  - Ensure that you have a place to retreat to in case of emergency.

Improper or unintentional manipulator operation can result in injury.

- Before operating the manipulator, check that servo power is removed when an emergency stop button is pressed.

Injury or damage to machinery may result if the manipulator cannot be stopped in case of an emergency.



### CAUTION

Perform the following inspection procedures prior to performing teaching operations. If problems are found, correct them immediately, and be sure that all other necessary processing has been performed.

- Check for problems in manipulator movement.
- Check for damage to insulation and sheathing of external wires.

### ■ Cautions for Connection of Dual Channel Safety Input Signals



## CAUTION

- Connect the switch (contact) that turns the dual signals ON and OFF simultaneously.
- If the timing that turns the two signals ON and OFF is not right, a disagreement alarm occurs. Refer to the figure below.

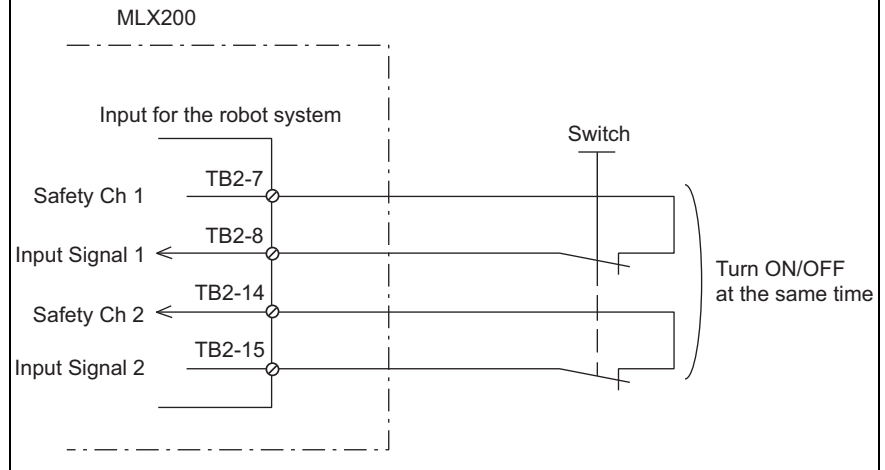

## CAUTION

- Do not connect two signals to the same contact point. (Prepare two individual contact points)
- Since the power supply for each signal is unique, it will cause a fault in the safety relay (CR502) if the signals are connected to the same contact point.

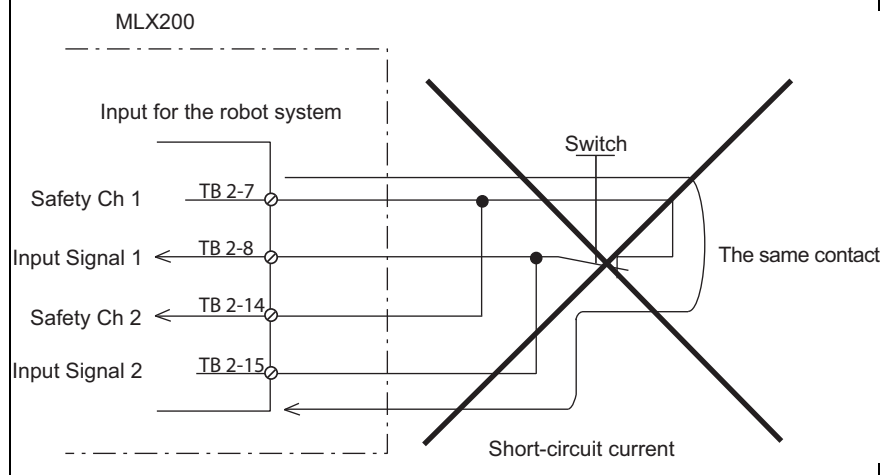



### ■ External Emergency Stop

This signal is used to connect the emergency stop switch of an external device. If the signal is input, the servo power is turned OFF and the job is stopped. While the signal is input, the servo power cannot be turned ON.



## CAUTION

- Always connect the signals after removing the jumpers.

If the jumpers are not removed, injury or damage to machinery may result and the external emergency stop will not work even if the signal is input.

Fig. 9-1: Connection for External Emergency Stop

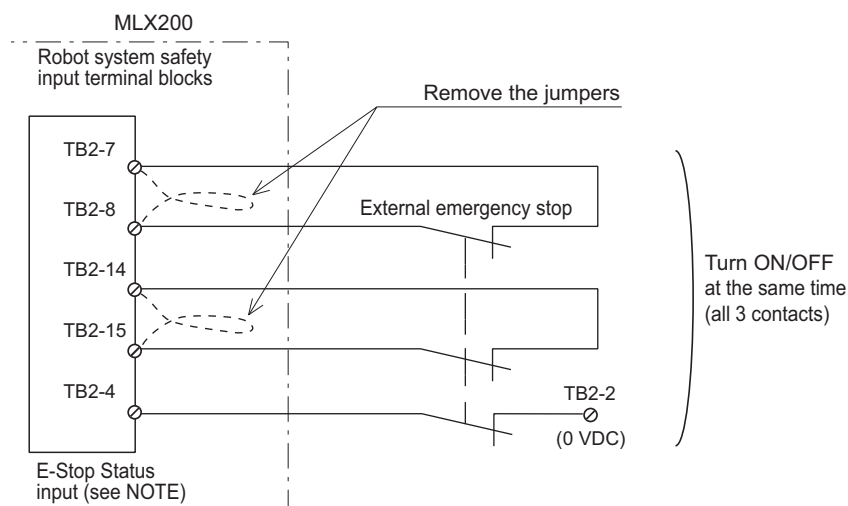

If multiple E-Stop buttons are present in the system, all contacts must be wired in series to the TB2-4 status input.

\*This includes the optional Teach Pendant's E-Stop signal.

### ■ Guard Device/ Gate Interlock

This signal is used to turn OFF the servo power if the door on the safeguarding is opened. Connect to the interlock signal from the safety plug on the safeguarding door. If the interlock signal is input, the servo power turns OFF. While the signal is turned ON. The servo power cannot be turned ON. Note that these signals are disabled in teach mode.

- Example devices include Light Curtains and Safety Gates



## CAUTION

- Always connect the signals after removing the jumpers.
- If the jumpers are not removed, injury or damage to machinery may result and the external emergency stop will not work even if the signal is input.

Fig. 9-2: Connection for Safety Plug

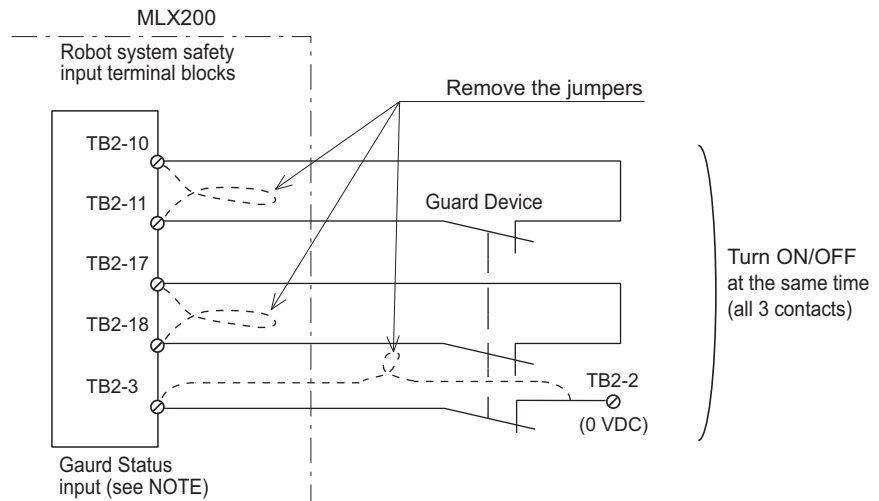

If multiple guarding devices are present in the system, all contacts must be wired in series to the TB2-3 status input.

### ■ Installation of Safety Plug

The manipulator must be surrounded by a safeguarding and a door protected by an interlock function. The door must be opened by the technician to enter and the interlock function stops the robot operation when the door is open. The safety plug input signal is connected to the interlock signal from the gate.

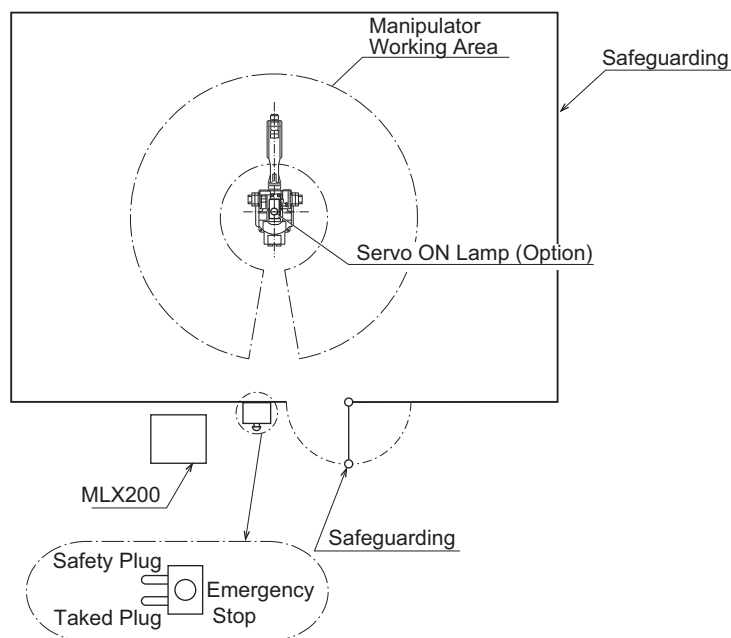

If the servo power is ON when the interlock signal is input, the servo power turns OFF. The servo power cannot be turned ON while the interlock signal is input. However, the servo power does not turn OFF when the door is opened only during the teach mode. In this case, the servo power can be turned ON while the interlock signal is input.

■ **External Enable Switch (Deadman Switch on Teach Pendant)**

This signal is used to connect an Enable switch such as the one on the teach pendant or an additional device when two people are teaching.



## CAUTION

- Always connect the signals after removing the jumpers.

Injury or damage to machinery may result because the external emergency stop do not work even if the signal is input.

Fig. 9-3: Connection for External Enable Switch

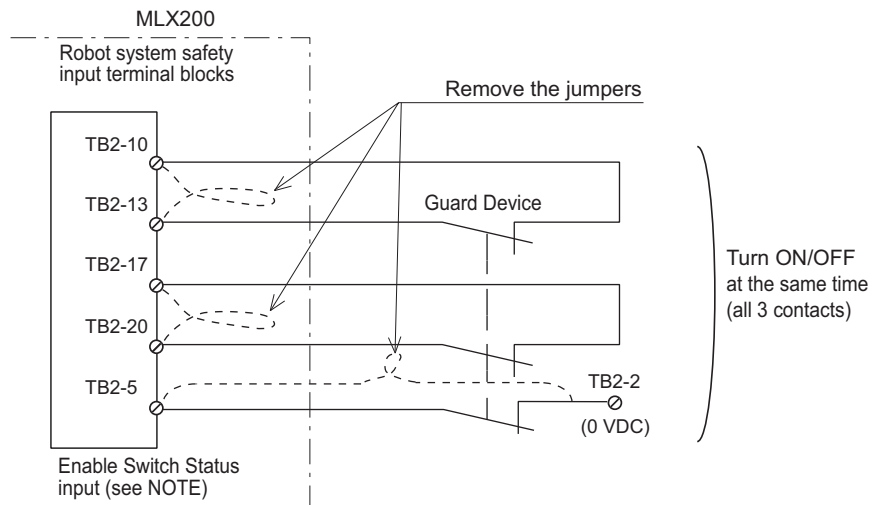

- If multiple External Enable Switches are present in the system, all contacts must be wired in series to the TB2-5 status input.
- If a teach pendant is also used, the enabling device(s) should be wired in series with teach pendant enable switch.
- Refer to the Pendant Interface Kit drawing, 165143-1, for wiring of the Fuji Pendant. Refer to *Appendix A* for suggested wiring of the Rockwell MobileView teach pendant.

Table 9-1: Signal Connections and Settings

Signal Name	Connection No. (TB2)	Dual input	Function	Factory Setting
EXTESP1+ EXTESP1-	TB2-7 TB2-8	Applicable	External Emergency Stop	Switch included and wired.
EXTESP2+ EXTESP2-	TB2-14 TB2-15		Used to connect the emergency stop switch of an external device. If the signal is input, the servo power is turned OFF and the job is stopped. While the signal is input, the servo power cannot be turned ON.	
PPESP1+ PPESP1-	TB2-8 TB2-9	Applicable	Teach Pendant Emergency Stop	Short-circuit jumpers (Wired when purchased with a Fuji Teach Pendant.)
PPESP2+ PPESP2-	TB2-15 TB2-16		Used to connect the emergency stop switch of an external device. If the signal is input, the servo power is turned OFF and the job is stopped. While the signal is input, the servo power cannot be turned ON.	
PBESP1+ PBESP1-	TB2-9 TB2-10	Applicable	Push Button Emergency Stop	Short-circuit with jumpers
PBESP2+ PBESP2-	TB2-16 TB2-17		Used to connect the emergency stop switch of an external device. If the signal is input, the servo power is turned OFF and the job is stopped. While the signal is input, the servo power cannot be turned ON.	
E-Stop Status	TB2-4	Single	Emergency Stop Status Monitor	Wired to include switch (with or without Teach Pendant)
			Allows the software to know the state of the E-Stop button(s).	
			If multiple E-Stop buttons are used, all buttons must provide status contacts, which will be wired in series to this input.	
GATEINT1+ GATEINT1-	TB2-10 TB2-11	Applicable	Safety Plug/ Gate Interlock	Short-circuit with a jumper cable
GATEINT2+ GATEINT2-	TB2-17 TB2-18		Used to turn OFF the servo power if the door on the safeguarding is opened. Connect to the interlock signal from the safety plug on the safeguarding door. If the interlock signal is input, the servo power turns OFF. While the signal is turned ON. The servo power cannot be turned ON. Note that these signals are disabled in teach mode.	
GUARD STATUS	TB2-3	Single	Safety Plug/ Gate Interlock Status Monitor	Jumper to 0 V <sub>DC</sub> by default
			Allows the software to know the state of the guarding protecting devices.	
			If multiple guarding devices are used, all devices must provide status contacts, which will be wired in series to this input.	
EXDSW1+ EXDSW1-	TB2-10 TB2-13	Applicable	External Enable Switch	Short-circuit with a jumper cable (Wired when purchased with a Fuji Teach Pendant.)
EXDSW2+ EXDSW2-	TB2-17 TB2-20		Used to connect the Enable/ 3-Position Switch from the teach pendant used for teaching.	

Signal Name	Connection No. (TB2)	Dual input	Function	Factory Setting
ENABLE/ DEADMAN SWITCH STATUS	TB2-5	Single	External Enable Switch Status Monitor	Jumper to 0 V <sub>DC</sub> by default
			Allows the software to know the status of the External Enable Switch.	
			If multiple Enabling units are used, all units must provide status contacts, which will be wired in series to this input.	
AUTO 1+ AUTO 1-  AUTO 2+ AUTO 2 -	TB2-11 TB2-12  TB2-13 TB2-12	Applicable	Auto (Play) Mode Selection	Switch included and wired.
Used to indicate mode selection. When these signals are ON the Safety Gate must remain closed for the robot to maintain the SERVO ON state.				
MANUAL 1+ MANUAL 1-  MANUAL 2+ MANUAL 2 -	TB2-18 TB2-19  TB2-20 TB2-19	Applicable	Manual (Teach) Mode Selection	Switch included and wired.
Used to indicate mode selection. When these signals are ON the Enable/ Disable signals must remain closed to maintain the SERVO ON state.				
AUTO/ MANUAL PLAY/ TEACH STATUS	TB2-6	Single	Auto/ Manual or Play/ Teach Status Monitor	Wired to the included switch.
			Allows the software to know the state of this switch.	
TEACH PENDANT IN USE	TB2-30	Single	Teach Pendant in Use Input	
			Indication to the software for the status of a Teach Pendant's connectivity. This is used to enforce single point of control. When the MobileView solution is used, the user or integrator is responsible to complete and verify the wiring and schematics.	

**9.1 SERVOPACK**

A SERVOPACK in the MLX environment consists of a converter, PWM amplifier, and EtherCAT communication option card.

**9.1.1 SERVOPACK Configuration***Table 9-2: Servopack Configuration*

<b>MH5S, MH5LS, MH5S II, MH5LS II</b>		<b>MH12</b>		<b>HP20D</b>		<b>MPK50</b>		<b>MPL80, MPL80 II</b>		<b>MPL160, MPL160 II, MPL300, MPL300 II</b>	
Model		Model		Model		Model		Model		Model	
SV0	157430-5	SV0	157430-1	SV0	157430-6	SV0	157430-9	SV0	157430-9	SV0	157430-9
SV1	157430-5	SV1	157430-6	SV1	157430-7	SV1	157430-9	SV1	157430-9	SV1	157430-9
SV2	157430-5	SV2	157430-1	SV2	157430-1	SV2	157430-9	SV2	157430-11	SV2	157430-9
SV3	157430-10	SV3	157430-10	SV3	157430-5	SV3	157430-2	SV3	157430-6	SV3	157430-11
SV4	157430-10	SV4	157430-10	SV4	157430-5			SV4	157430-6		
SV5	157430-10	SV5	157430-10	SV5	157430-5						

## 10 MLX200 Control Module Software Version Upgrade Procedure

Follow the steps below when installing a new MLX200 Control Module software version. By following the steps below this ensures the cell specifics and system operations data is imported.

### 10.1 Upgrade the Application on the MLX200 Control Module

The MLX200 Control Module software upgrades includes a maintenance tool to make it easier to upgrade new versions of software on the MLX200 Control Module.

1. Click on cerhost.exe.

MLX200-x.x.x > Tools > MLX200 Remote Display Application > cerhost.exe

2. In the File tab, choose Connect. The MLX200 Control Module will appear in the list of devices in a few seconds. Once it appears, click on the MLX200\_Control and press the [OK] button.

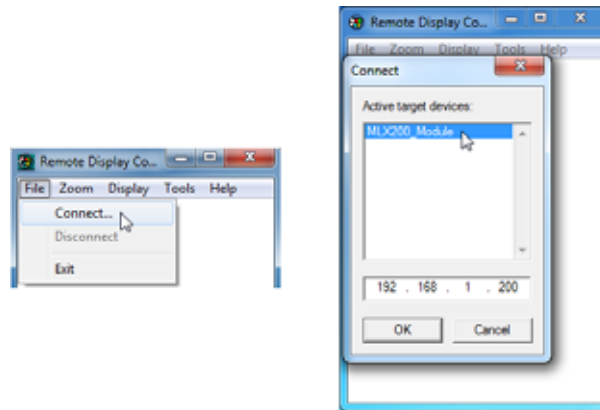

3. Press [Login], and enter "mlx200" for the password.

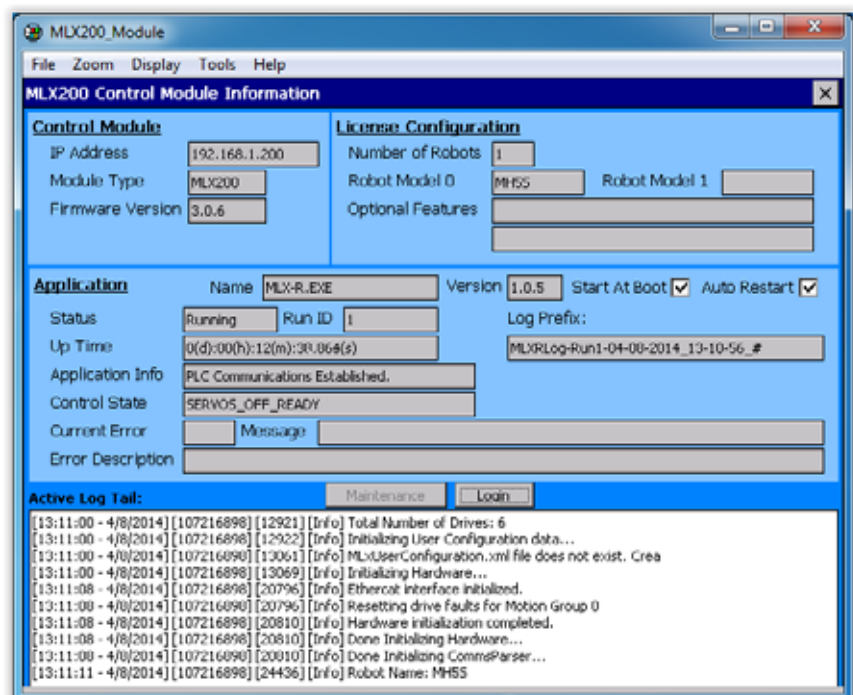



4. Press the [Maintenance] button.
5. Copy the entire folder supplied with the firmware update package to a USB Disk. Then insert this USB Disk into an available USB port on the MLX200 Control Module.
6. From the Maintenance Operations screen on the control module, click on the [Upload/ Restore] category on the left and select the [Update MLX200 Control Module Firmware]. Press the [Execute] button.

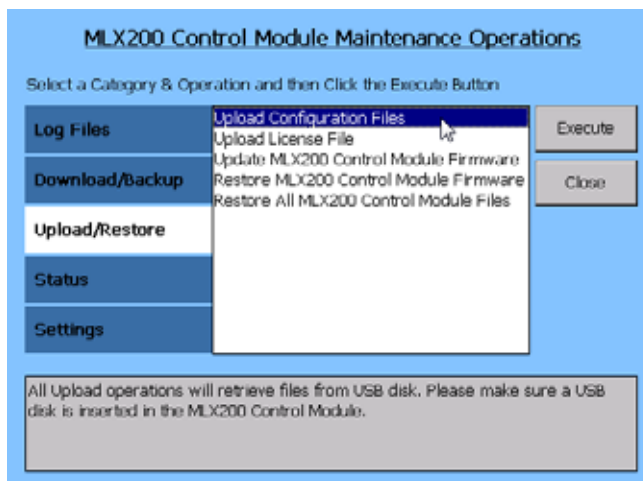

7. Select the folder that contains the firmware update files and click the [Select] button.

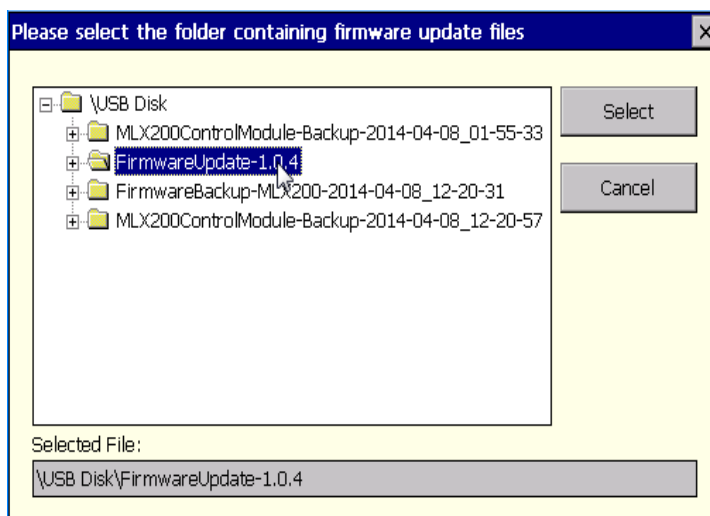

8. The Maintenance Tool will first perform verification of the integrity of the update files and then prepare the Control Module for the update operation. Once this preparation is complete, the actual firmware update task will be performed after a reboot of the Control Module.

9. To reboot the MLX200 Control Module, click on the [Settings] category on the left and select the [Update MLX200 Control Module Firmware]. Press the [Execute] button, and then [OK].

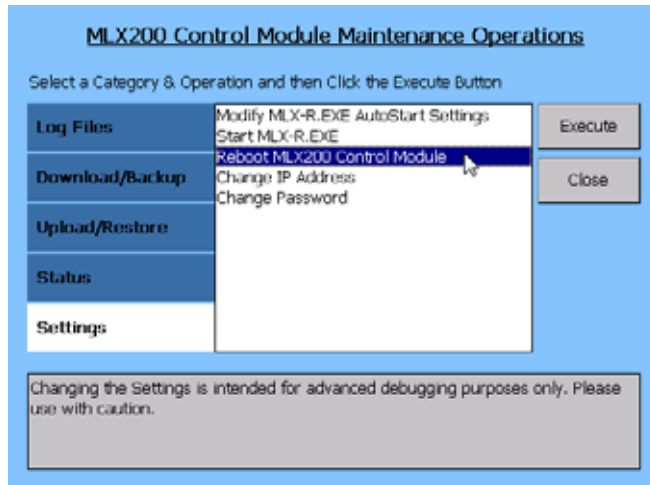

10. After rebooting, the main MLX200 Control Module Information screen will show the updated version.

## 10.2 Export Robot Data for RSLogix Ladder

1. Using the MLXData200 Software, export the teach points, interference zones, tools, and user frames.
  - a) With the PC connected to the Ethernet switch, double click on the MLxData200.exe file.

Make sure the following files are in the same directory:



- MLXData200.exe
- MfgControl.AdvancedHMI.Drivers.dll
- Microsoft.VisualBasic.PowerPack.Vs.dll
- 169456-1CD.pdf

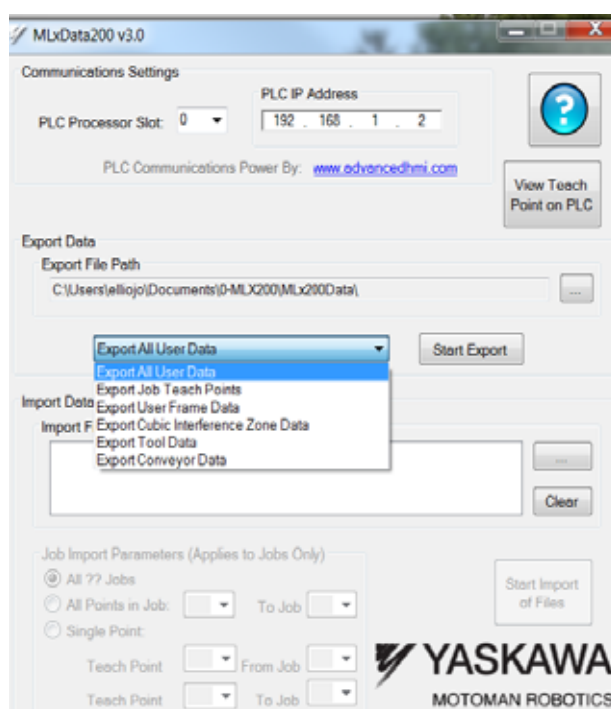

2. On the MLxData200 screen, select the robot number the PLC processor slot number and the IP address of the PLC Ethernet card.
3. Press [...] in the Export Data section of the MLxData200 screen to select the desired storage data directory location.

4. Select [Export All User Data] from the pull down list, and press [Start Export]. The following files will be exported.

Actual File Name	What the File Is
MLxData200 Teach Points.txt	Teach Points of each Job
MLxData200 Tools.txt	Tools
MLxData200 User Frames.txt	User Frames
MLxData200 Interference Zones.txt	Interference Zones

\* There is an option to transfer all files at one time.



If there are files already in the directory, they will be overwritten.

### 10.3 Export non-MLX Tasks from the RSLogix Ladder

Export all PLC ladder tasks to the new PLC ladder if the tasks are to be operational after a software upgrade.

1. In the RSLogix Controller Organizer, right-click on the task, and select [Export program].
2. Confirm the file name and storage location, and press [Export].

### 10.4 Download New Version of MLX200 Control Module Software

1. Download new version of MLX200\_x\_x\_x\_CompactLogix.ACD or MLX200\_x\_x\_x\_ControlLogix.ACD ladder to the PLC.



The “x\_x\_x” represents the software version number in the file name. An example of the actual file name may be MLX\_D\_3\_1\_0.ACD.

### 10.5 Setup I/O Configuration in RSLogix Ladder

1. Insert devices into the I/O Configuration of the ladder and copy board software revision numbers from the old ladder.

### 10.6 Import Tasks into the New RSLogix Ladder

1. In the RSLogix Controller Organizer, right click on [Unscheduled Programs/ Phases], and select [Import Program].
2. Browse to the desired file and press [OK] by referencing *section 10.3 “Export non-MLX Tasks from the RSLogix Ladder”*.
3. Resolve alarms after importing tasks. For instance, if a modified AOI has different data types or new entries, the old AOI needs to be deleted and replaced with the new AOI. Re-establish tags by right-clicking on the tag, and selecting [New].

## 10.7 Import the Robot Data into RSLogix

Using MLx200 Job software, re-load the Job Teach Points, Interference Zones, Tools and User Frames by referencing *section 10.2 “Export Robot Data for RSLogix Ladder”*.

1. Place the PLC in program mode.
2. In the Import Data area of the MLx200 Job main screen, press [...] to browse to a directory location where the data was stored.
3. Highlight each file to be imported, by pressing [Cntrl]-[Left Mouse Button], and press [Open]. Observe all data in *section 10.2 “Export Robot Data for RSLogix Ladder”* is imported into the new RSLogix ladder.
4. Press [Start Import of Listed Files].
5. After files are imported, a confirmation message will be displayed. Press [OK] to continue.



## 10.8 Configure the new MLX200-HMI file to see the “MLX200x\_x\_x” processor.



The “x\_x\_x” represents the software version number in the file name. An example of the actual file name may be MLX200\_HMI\_1\_2\_0.mer. MER files are no longer provided as of version 1.3 release. Now all MLX200 systems include a more flexible APA file which allow easier customization and deployment.

1. Refer to *chapter 13 “HMI Communications Setup Procedure”* and complete the steps on how to setup the Factory Talk View HMI when a MER is used. (This should only be required for MLX200 software versions 1.2 or earlier.)

---

## 10.9 Teach Pendant Software Upgrade.

If a Fuji teach pendant is installed on the cell, complete *chapter 11 "Teach Pendant Software Upgrade Procedure (Fuji Pendant)"* steps.

If a MobileView teach pendant is installed on the cell use the APA file provided with the newer version of MLX200 software.

## 11 Teach Pendant Software Upgrade Procedure (Fuji Pendant)

These steps are for the Fuji Teach Pendant (V8). If Rockwell's MobileView is used, this section is not applicable.

Follow the steps below when installing a new MLX software version or adjusting the IP address of the PLC or teach pendant in the system. By following the steps below this ensures the cell specifics and system operations data is imported.

Alarm 205 or 801 will display if communication is not successful.



Complete the following steps to resolve and diagnose the communication problems.

## 11.1 Configure PC to use a Static IP

1. Attach Ethernet cable between the teach pendant and the PC.
2. Open the Internet Protocol (TCP/ IP) Properties screen.
3. Select “Use the following IP address”:

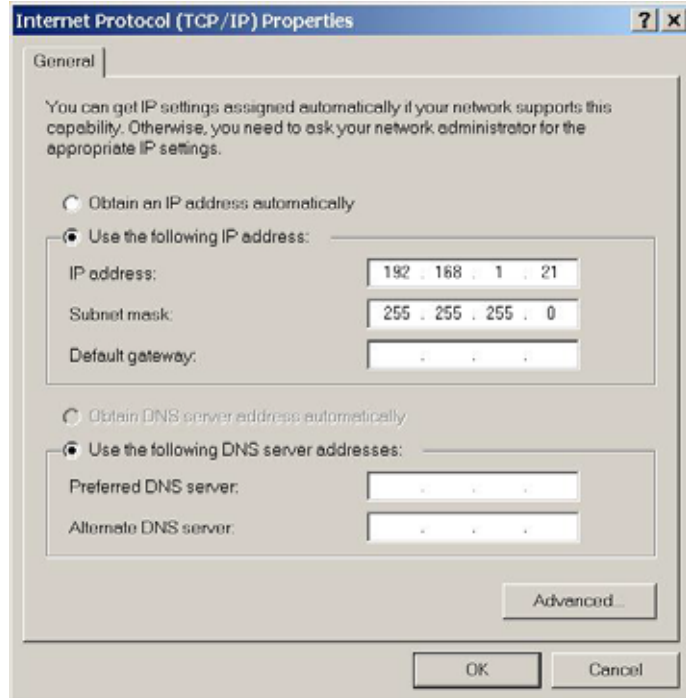

4. Set the IP address of the PC to 162.168.1.21.



**11.1.1 Prepare Pendant to Set the IP Address for the NEW/  
UN-PROGRAMMED System**

After power up, if the screen below is displayed, this is an un-programmed pendant if this screen does not appear complete *section 11.1.2 “Prepare Pendant to Change IP Address for an Upgraded System”*



1. Press [IP ADDRESS] button on screen.
2. Press [EDIT] on the new screen.
3. Proceed to *section 11.1.3 “Setting IP Address for Pendant”*

**11.1.2 Prepare Pendant to Change IP Address for an Upgraded System**

Ensure the screen in *section 11.1.1 “Prepare Pendant to Set the IP Address for the NEW/ UN-PROGRAMMED System”* is not present before performing the following steps. If the screen is present perform *section 11.1.1 “Prepare Pendant to Set the IP Address for the NEW/ UN-PROGRAMMED System”* instead of the following steps.

1. Press the SYSTEM key on the pendant (purple, right side).
2. Press the F1 key (this should say MODE on the screen).
3. Press [Main Menu] on the touch screen.
4. Press [Ethernet] on the touch screen.
5. Press [Edit] on the next screen.
6. Proceed to *section 11.1.3 “Setting IP Address for Pendant”*

**11.1.3 Setting IP Address for Pendant**

The following steps are completed after either *section 11.1.1 "Prepare Pendant to Set the IP Address for the NEW/ UN-PROGRAMMED System"* or *section 11.1.2 "Prepare Pendant to Change IP Address for an Upgraded System"*.

1. Set the IP address to 192.168.1.100, if required.
2. Set the Control Module to 0.0.0.0, if required.
3. Set the Sub-mask to 255.255.255.0, if required.
4. Press [Setting Finished] on the touch screen (bottom right).
5. Verify the IP address displays on the Main Setting screen.

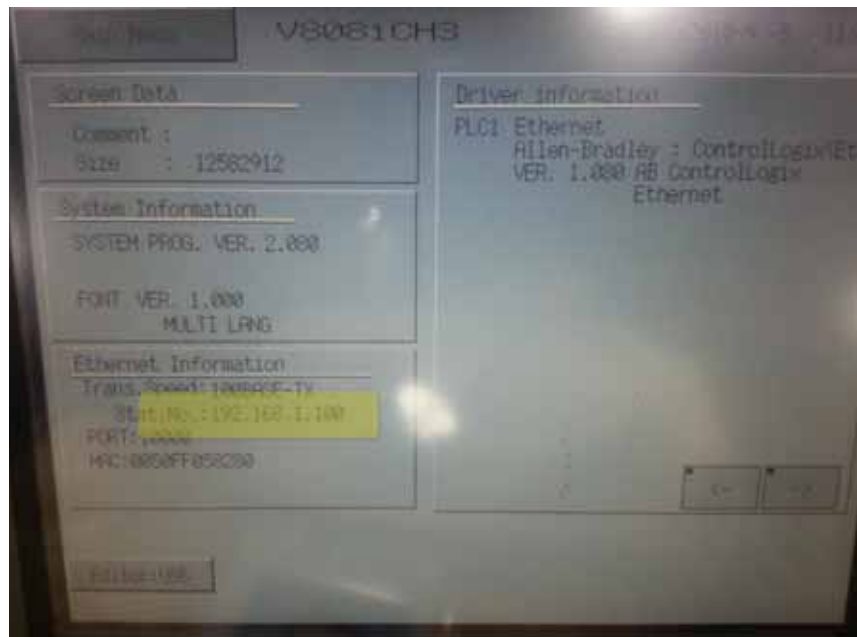

6. Verify Communication between the computer and the teach pendant
  - a) Start a command prompt (cmd.exe).
  - b) Type PING 192.168.1.100



If the command is not successful the IP address is not set correctly in the Teach Pendant or PC, or there is a failure with the Ethernet cable connection.

7. Determine which version of V-SFT Monitouch programming software you have:
  - If VSFT version 5 go to section 11.2.
  - If V-SFT version 6 go to section 11.4.



- Yaskawa part number 160708-1 is V-SFT version 5.
- Yaskawa part number 160708-2 is V-SFT version 6.
- V-SFT version 6 started shipping in 2015. Prior to that all systems were supplied with V-SFT version 5.

## 11.2 Setup the Fuji V-SFTV5 Monitouch Program

1. Start the Fuji V-SFTV5 Monitouch programming software.

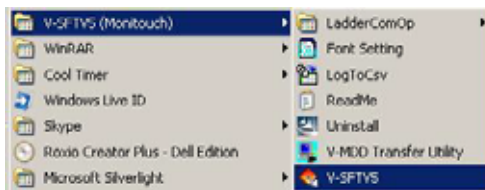

2. Open the project file (\*.v8).
3. From the left hand window, navigate to: Device Connection Settings and then double click on "PLC1". In the window on the right, change the tabbed view to show "Target Settings" as shown.

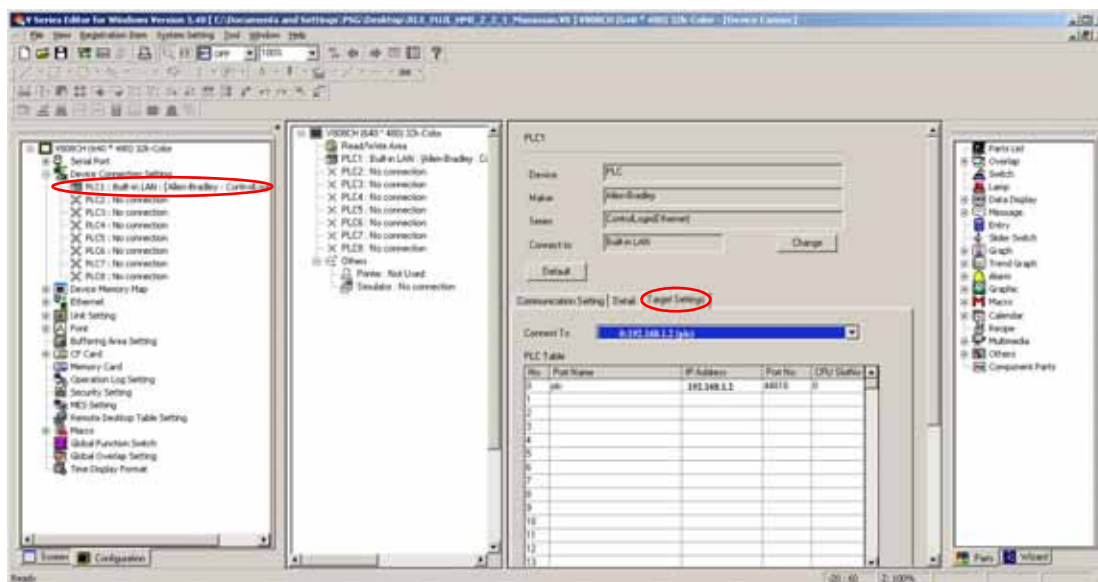

4. Enter the IP address as 192.168.1.2



- The IP address may differ and should be checked with the IP address on the bare arm PLC test station - this will cycle across the EtherNet/ IP module.
- Do not change the port or communication problems will occur.
- If this is a custom system this IP address should be set the same as the address of the ControlLogix Ethernet/ IP card.

5. Adjust the network table by navigating to Ethernet and double clicking on "Network Table" in the left hand window.

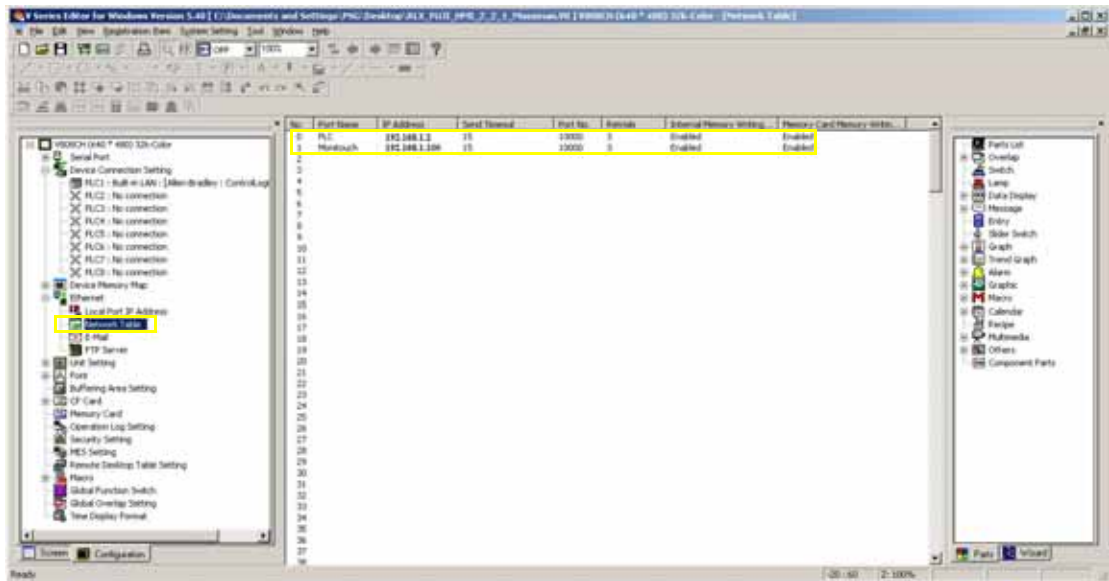

6. Set the "PLC" IP to 192.168.1.2 refer to *step 3* for a custom setting.
7. Set the "Monitouch" IP to 192.168.1.100.



To modify an address, first click on the No. next to the port name.

**11.3 Transfer Screen Data to Teach Pendant (Version 5)**

1. Select "Transfer" from the File menu and verify the IP address of the pendant at bottom of the screen is correct (192.168.1.100)



If the correct address is not displayed, press [Communication Setting...], and select "Ethernet". Enter the correct IP address and press [OK].

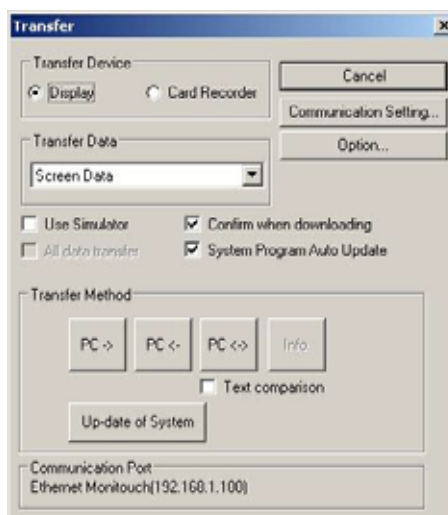

2. Press the first [PC->] button to transfer from the PC to the Teach Pendant
3. Observe the following screen appears and press [OK].

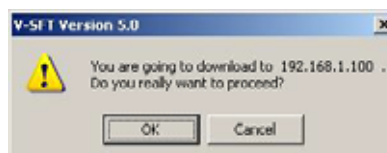

4. Observe the following screens appear on the PC and a blue message in the bottom left corner of the Teach Pendant saying "TransferData" indicating a transfer is taking place

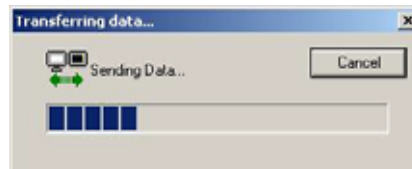

5. Observe when transfer is complete nothing appears to confirm success.

- If this message appears means some failure in the communication setup.

**NOTE**

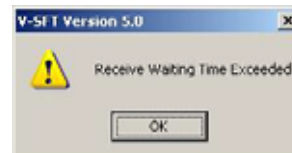

- If a "ping" was verified in *section 11.1 "Configure PC to use a Static IP" step 6* then check all other settings in the software setup and repeat.

## 11.4 Setup the Fuji V-SFTV6 Monitouch Program

1. Start the Fuji V-SFTV6 Monitouch programming software.



2. Open the project file (\*.v8)
3. From Main Menu, go to "System Settings" and press the "Hardware Setting" icon:

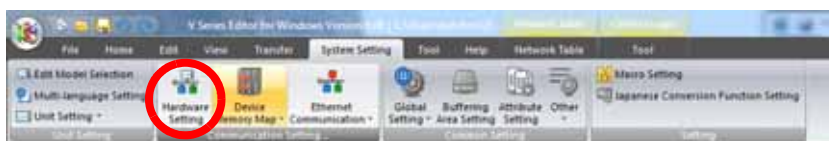

4. Press "PLC1" – this can be either of the two icons below.

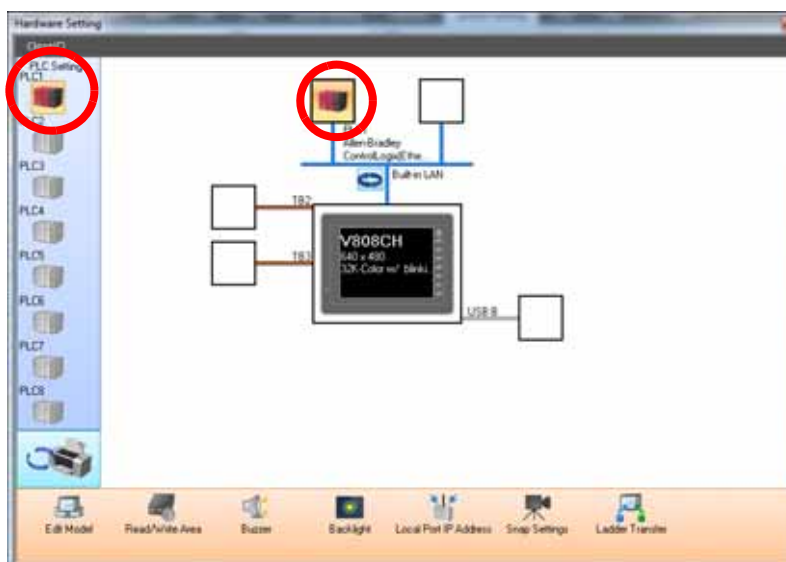

5. Press the blue text – “Setting...” on the Hardware Setting window that appears.

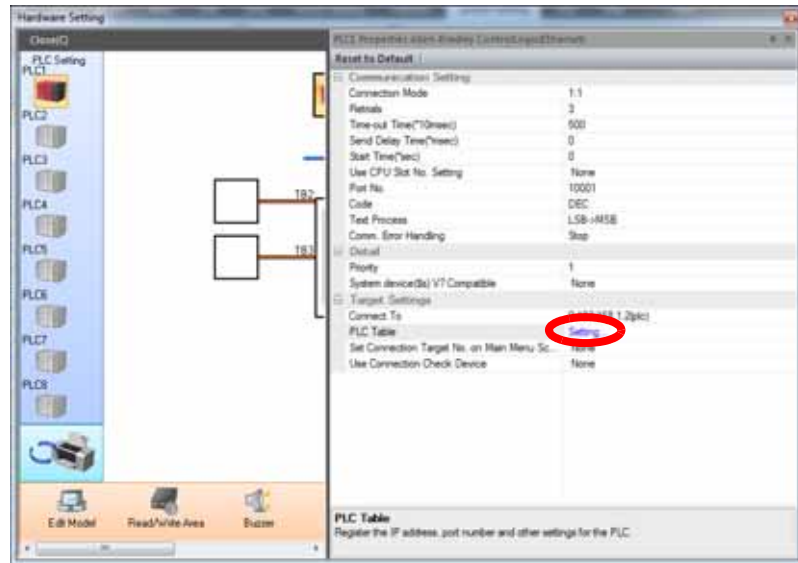

## CAUTION

Do not edit the PLC Table, Port Name.

Editing the PLC Table Port Name can cause the software to work incorrectly or not at all.

6. Enter the IP address from the bare arm PLC test station that cycles across the EtherNet/ IP Module into “No 0” of the PLC Table that appears.

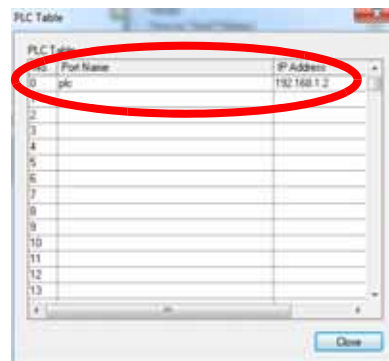

- The normal IP address from the bare arm PLC test station is 192.168.1.2.
- If this is a custom system the IP address should be set the same as the address of the Ethernet/ IP card for the PLC.

7. Close both windows and save the project.



**11.5 Transfer Screen Data to Teach Pendant (Version 6)**

1. Go to Main Menu, select “Transfer” then press the “Download” icon:



2. Observe the IP address displayed at the bottom of this window.
  - a) If the correct address is not displayed press “Communication Settings...,” button and select “Ethernet”. Enter the IP address 192.168.1.100 and press “OK”.

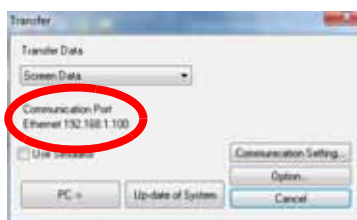

- b) Press the “Up-date of System” button.
- c) If prompted that the “V8080CH.prg” file is the same version press the “Transfer All” button

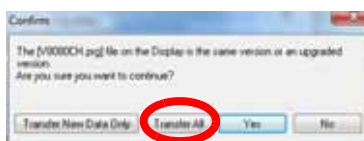

- Wait for updates to complete
  - System update
  - Font update
  - Comm driver update

3. Again, go to Main Menu, select “Transfer” then press the “Download” icon:



4. Press the [PC ->] button to transfer the program to the unit.

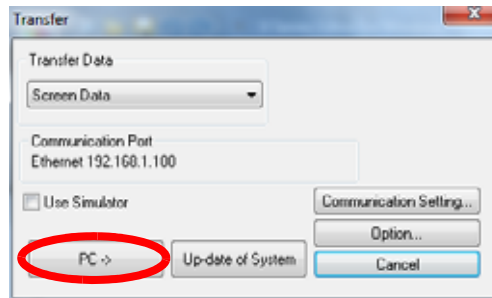

- The following screens indicate that data is transferring successfully

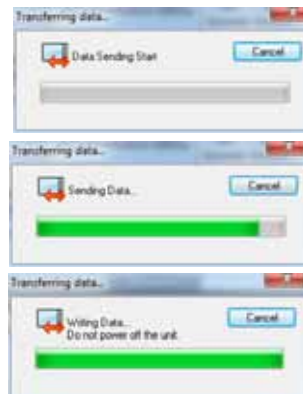

- A blue message appears in the bottom left corner of the Teach Pendant indicating “**Transferring Data**” when project files are transferring to the hardware.
- If a failure notice appears;

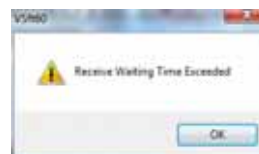

- If the message “Receive Waiting Time Exceeded” is received there is a failure in the communication setup.
- If a “ping” is verified, check all other settings in *Section 11.4 “Setup the Fuji V-SFTV6 Monitouch Program” on page 11-9* and repeat.
- Notice appears confirming success of the transferring data.



If you get distracted and look away you may miss the successful transfer confirmation.

## 11.6 Install the MLX Version Label

Place the MLX version label on the back of the pendant to indicate the software version.



## 12 Sigma-5 Amplifier Parameter Upgrade Procedure

1. Attach a USB cable between the PC, and the SV0 port labeled CN7.
2. Start the SigmaWin+ program, select [Online] mode and then click [Search].

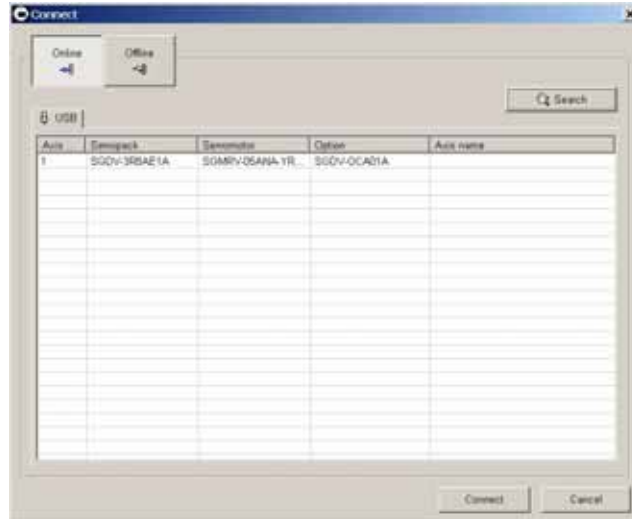

3. When the “Search Condition Setting” screen appears select:
  - Only [Sigma  $\Sigma$ V] under the “Target Servopack Series Setting” section.
  - [Search] under the “USB” tab



If Search was missed or not selected contact Motoman Customer Service for driver help.



4. Press the [Search] button at the bottom of the Search Condition Setting screen.

5. Observe the Searching screen appears indicating that SigmaWin has begun searching.



6. Observe a Servopack and Servomotor with Option is available, if successful. Click on the item in the list and select [Connect].

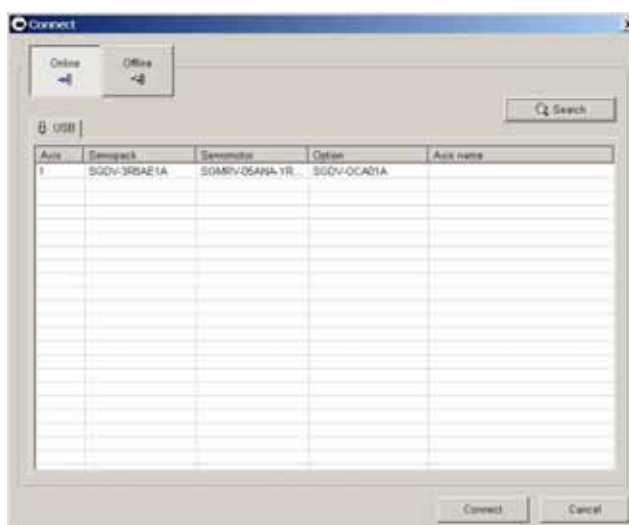

7. Go to the Parameters menu and select Edit Parameters.



8. Select [Import] from the Parameter Editing screen.

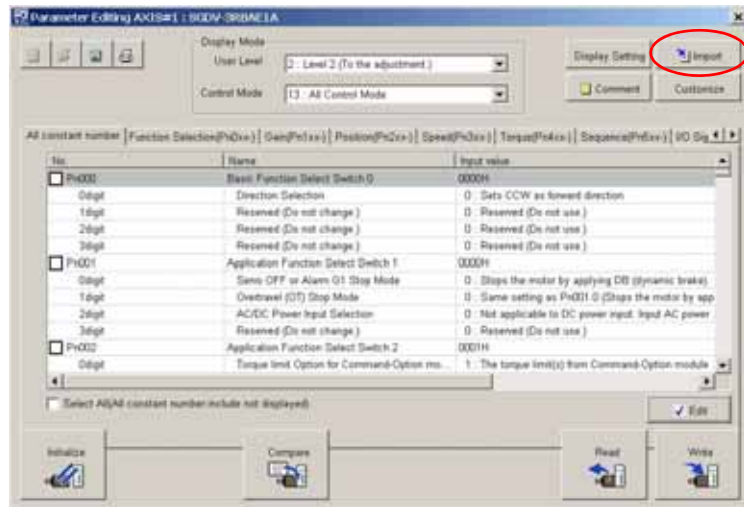

9. Select the file for this servopack and press [Open].

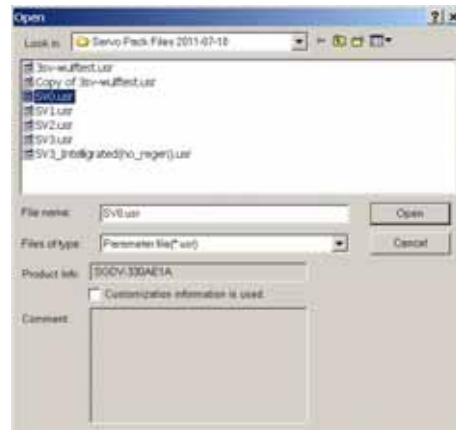

10. Select the checkbox "Select All" and press [Write].

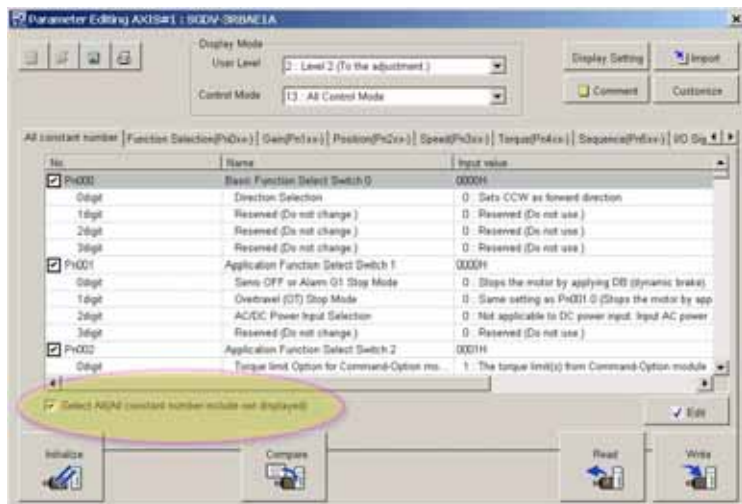

11. Observe transfer screen appears showing parameters are transferring.



12. Press [OK] when the "Verification" screen appears.

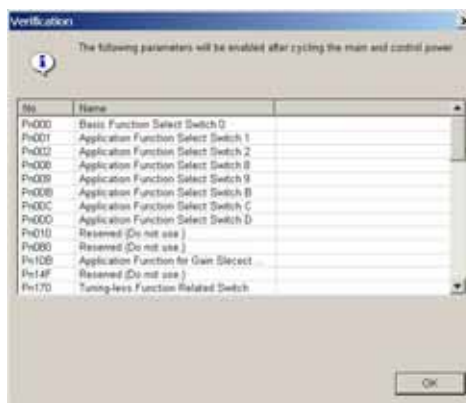

13. Move the USB cable to the next servo pack. Select the [File] tab, and press [Connect].

14. Repeat *step 2* through *step 12* for all servo packs on the panel.



The number of servo packs will vary based on the robot model.

15. Cycle power to the off position and then reapply power after 15 seconds.

## 13 HMI Communications Setup Procedure

### 13.1 Version Note

The processes described in chapter 13 apply to MLX200 software versions prior to 1.3. Software versions 1.3 and later include the APA file which allows the customer / user to easily customize and integrate this file using FactoryTalk View. Instructions on using the APA file are not provided as this is common practice when using Rockwell solutions.

### 13.2 Configuring Factory Talk Administration Console

1. Factory Talk ME station requires a few configuration steps to display the MLX HMI correctly. Before you can run the HMI runtime file, you need to confirm that the PLC is visible to all Rockwell Tools.
2. Select *Start -> Programs -> Rockwell Software -> Factory Talk Administration Console*.
3. Select the "Local" directory and press [OK].

*Fig. 13-1: FT Administration Console Directory*



4. After, the FactoryTalk Administration Console Explorer opens, select the Communications tab at the bottom of the screen.
  - a) If the PLC has not been configured on the local computer, you will see a screen like *Fig. 13-2*. Continue to *step 5*.

*Fig. 13-2: FT Administration Console Explorer*

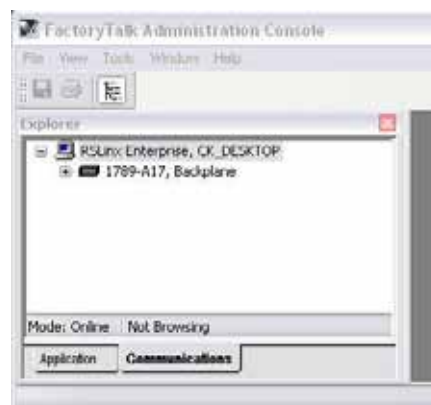



- b) If the PLC has already been configured on the local computer, you will see a screen like *Fig. 13-3*. Skip to *step 11* otherwise configure the Ethernet connections using *step 5* through *step 10*.

*Fig. 13-3: FT Administration Console Explorer with PLCs*

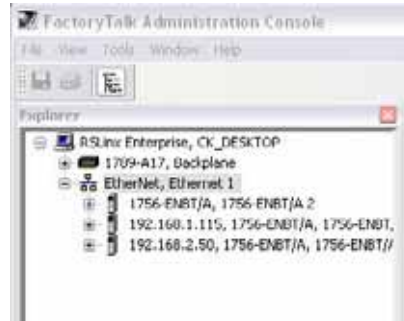

5. To allow for the Factory Talk Administration Console to see the PLC you will need to add a driver. Right click on the "RSLinx Enterprise" in the Explorer window and select "Add Driver", see *Fig. 13-4* "Administration Console - Adding a Driver".

*Fig. 13-4: Administration Console - Adding a Driver*

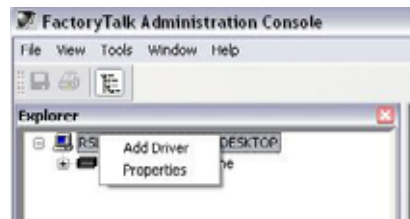

6. The add driver selection screen is shown in *Fig. 13-5* "FT Administration Console - Driver Selection". Select the Ethernet driver and click OK.

*Fig. 13-5: FT Administration Console - Driver Selection*

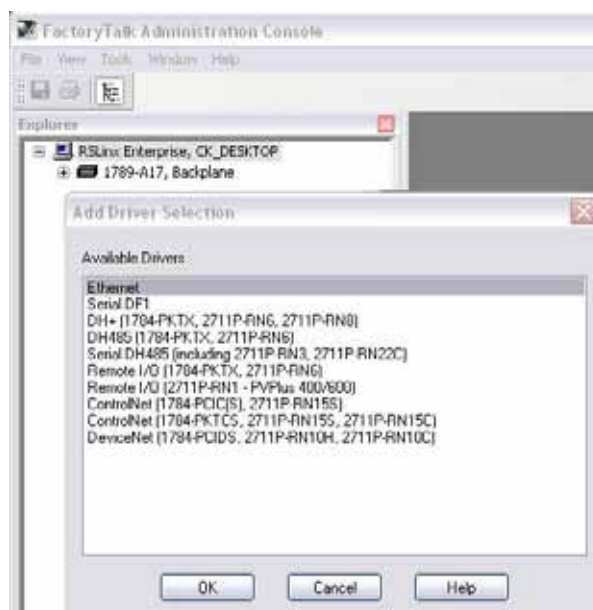

7. Next you will be presented with the “Ethernet Driver” properties screen shown in *Fig. 13-6 "Administration Console - Driver Configuration"*.

*Fig. 13-6: Administration Console - Driver Configuration*

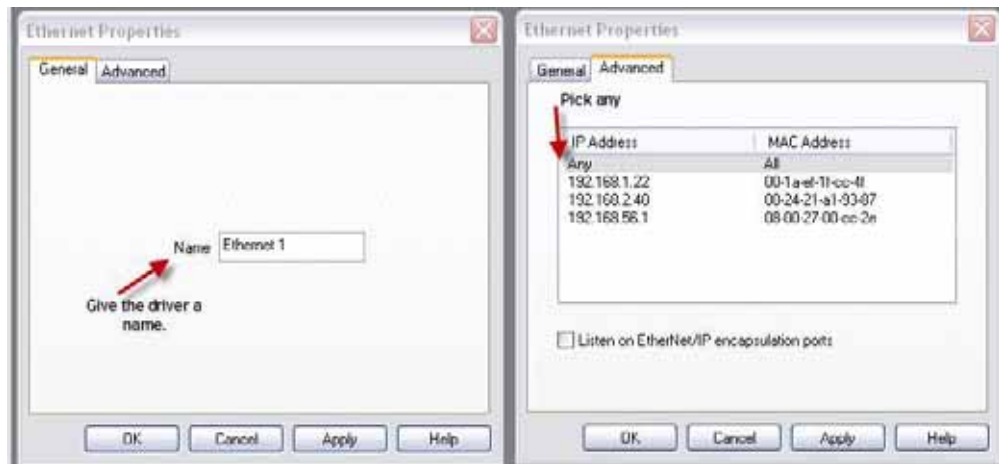

8. If the computer is connected to the PLC then you will start to see the PLC's on the network. If you do not see your PLC then right click on the “Ethernet” driver and add a device. See *Fig. 13-7 "Administration Console - Add Device"*.

*Fig. 13-7: Administration Console - Add Device*

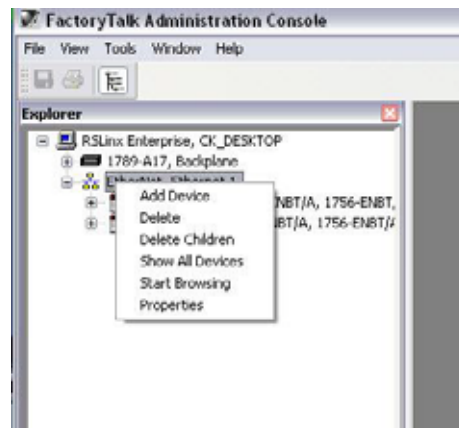

9. Now a “Device Properties” screen will open. Here you can name the device and assign it an IP address, see *Fig. 13-8*.

*Fig. 13-8: Administration Console - Device Properties*

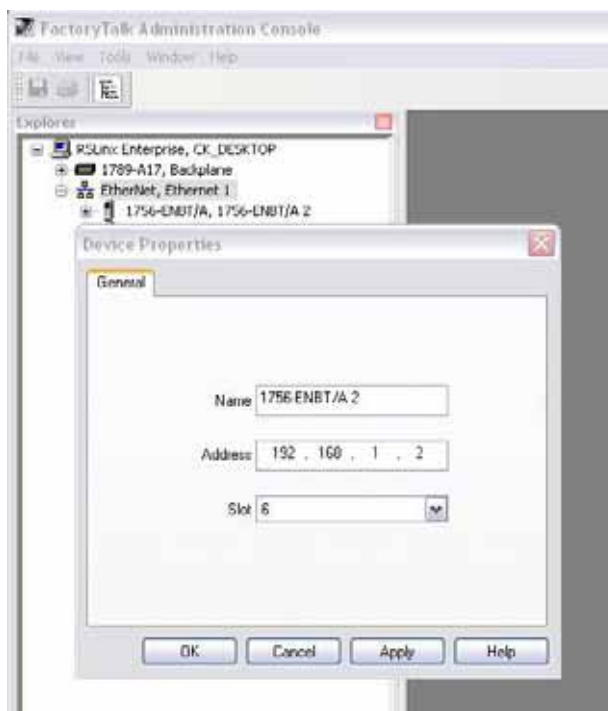

10. Once you have entered the correct IP address, click OK. After this step you should see your PLC in the Explorer window.
11. Open the RSLinx Enterprise tree, until the PLC processor is found.
12. Open the MLX200 RSLogix program and verify the processor name is the same in both applications.

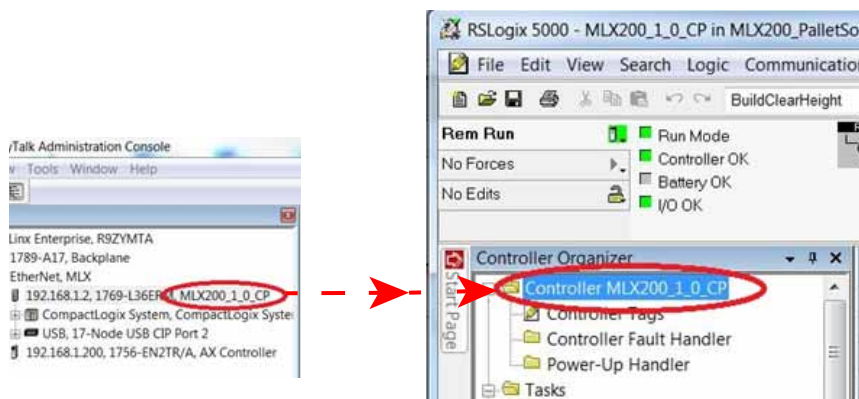

13. If the processor names are not the same, highlight the PLC processor in the FactoryTalk Administration Console. Right-Click and select Properties. Change the name to match the MLX200 RSLogix Control Module name.

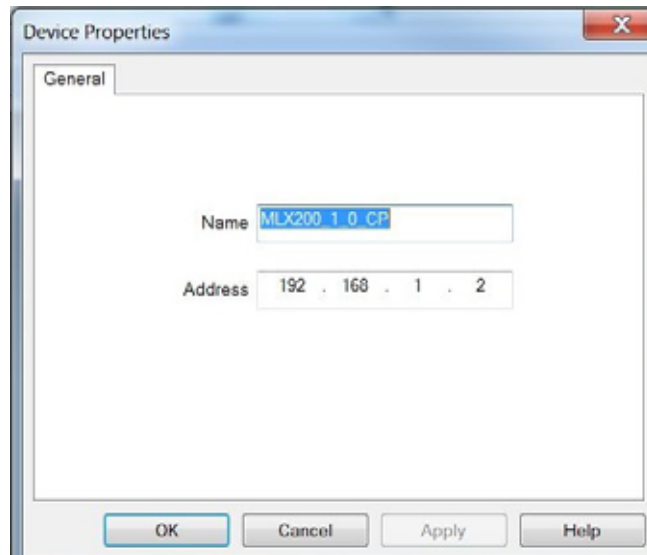

14. Close the FactoryTalk Administration Console.

### 13.3 Copy PLC Design to Runtime

1. Select Start → Programs → Rockwell Software → FactoryTalk View → FactoryTalk View Studio (Version 6.1 or newer)
2. Highlight “View Machine Edition”, and press [Continue].
- 3.a.If the HMI Customization option was purchased, select the existing Application Name that was re-stored from the MLX200\_HMI.apa file, and press [Open].
- 3.b.If the HMI Customization option was not purchased, select the New Tab, enter any Application Name (MLX200\_test), and press [Create].
4. Under the Explorer window, in the Application tab, find “RSLinx Enterprises” and expand. Double click on “Communications Setup”.

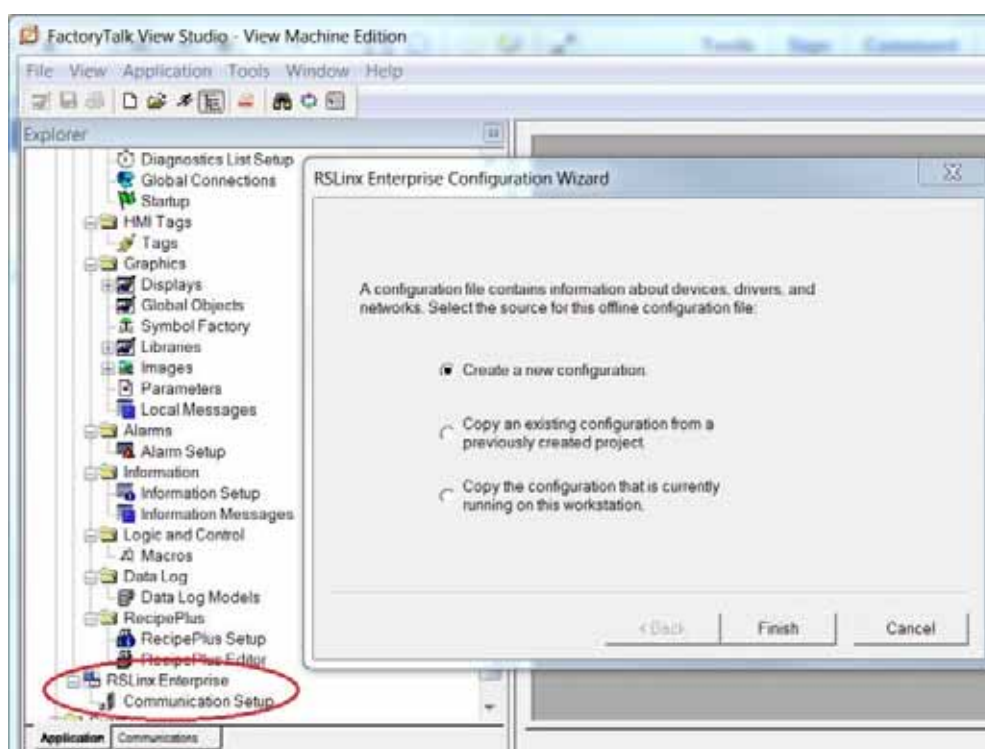

5. When prompted select “Create a new configuration”, and press [Finish].
6. At Device Shortcuts, press [Add], and name it “AX”.
7. Maximize the FactoryTalk View Studio screen to see all details.
8. On the right window, Design (Local), browse until the correct PLC Processor is found.
9. Verify that the Control Module name shown matches the name shown in RSLogix. If it doesn't, right-click on the Control Module and change the name.

10. Highlight the Control Module, and press [Copy from Design to Runtime]. When prompted, press [Yes].

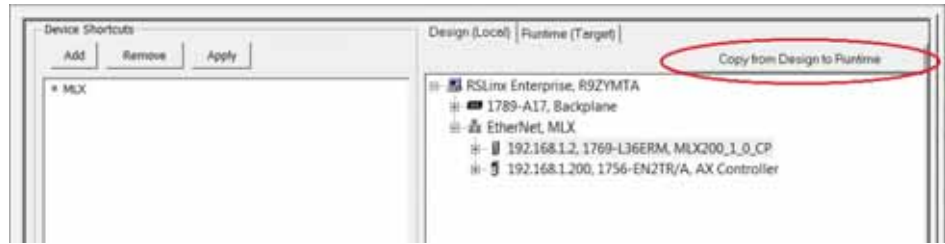

11. Press [OK] at the bottom of the screen, and choose [Yes] when prompted.
12. Close FactoryTalk View Studio.

### 13.4 Starting up the HMI

1. Click on the MLX200\_HMI.mer file to start up FactoryTalk View Machine Edition.
2. Select [YES] at the first prompt.

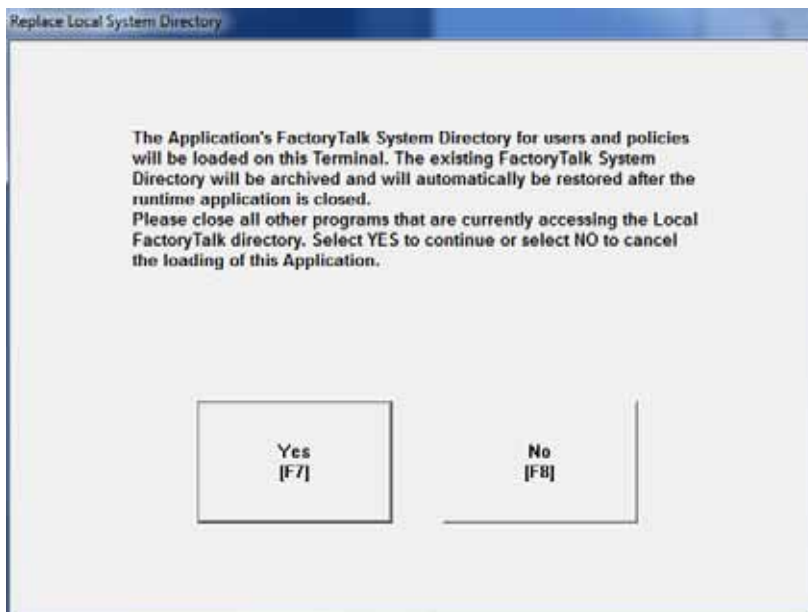

3. Click on [Terminal Settings].

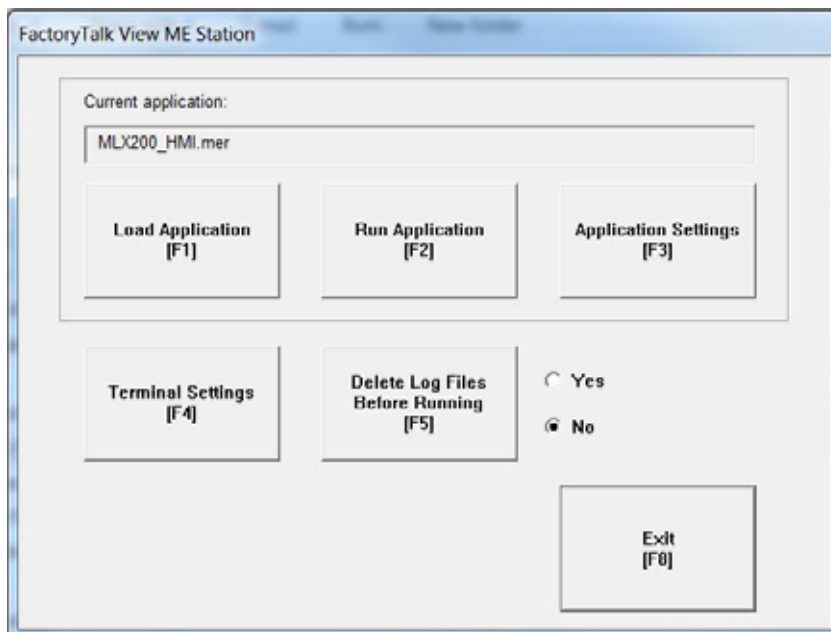

4. Select “Networks and Communications”, and press [Enter].

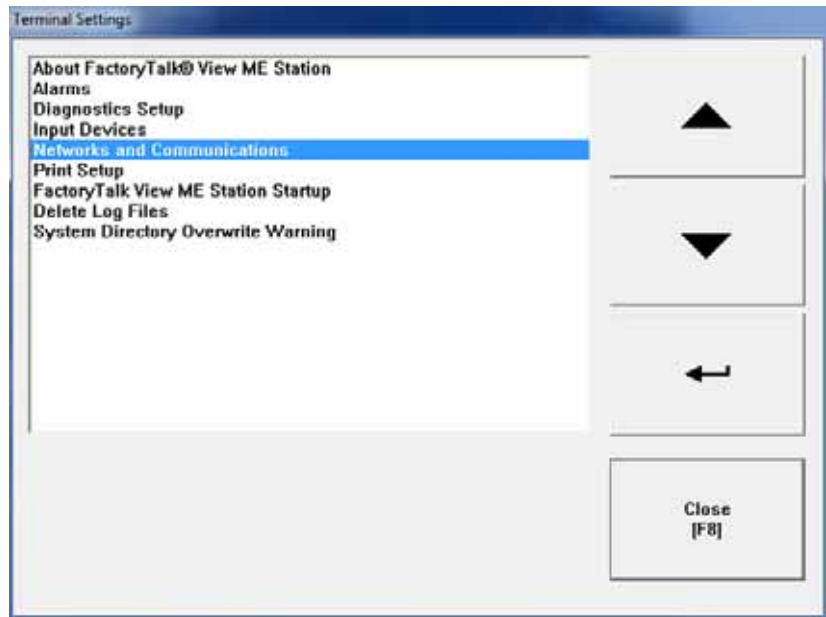

5. Select “RSLinx Enterprise Communications”, and press [Enter].

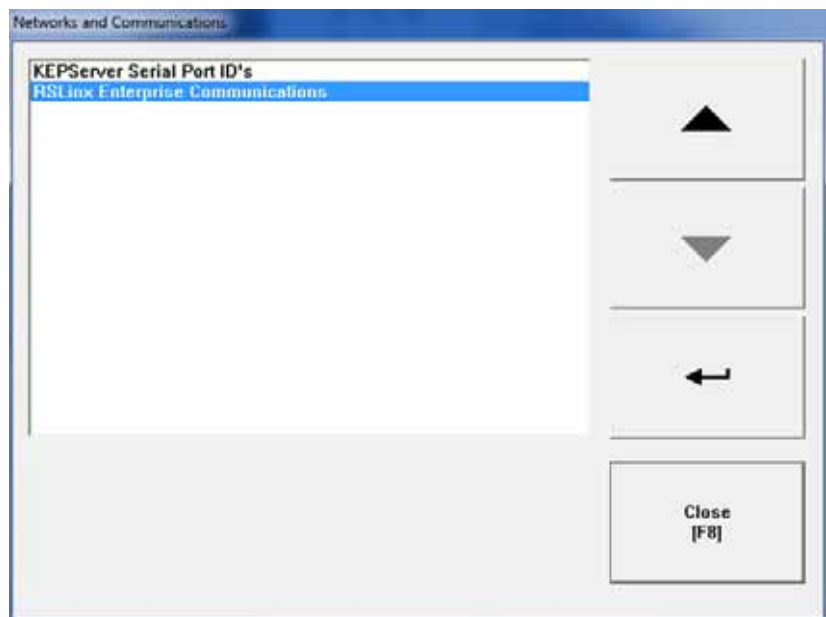



6. Highlight the MLX200 processor, and press [Close] three times to get back to the main screen.

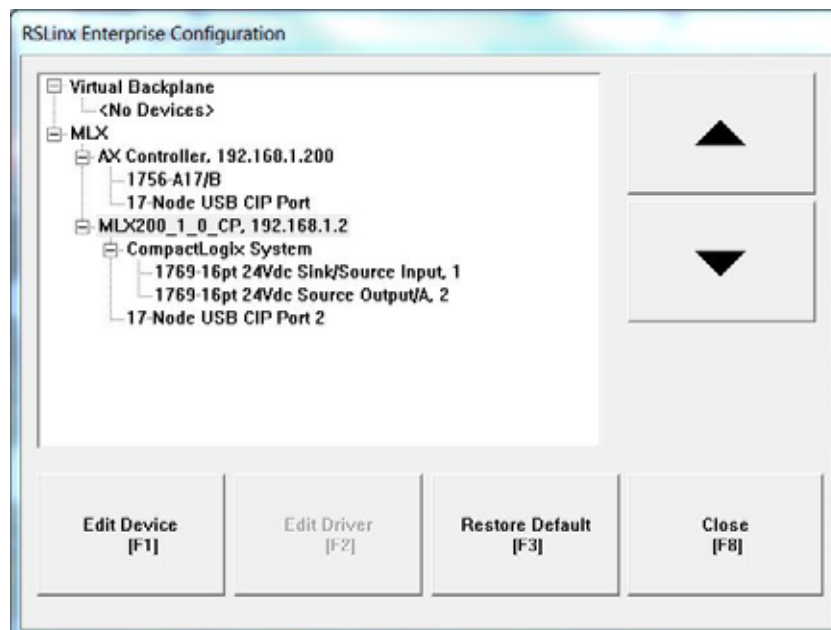

7. Click on [Application Settings], (see “FactoryTalk View ME Station” screen in step 3.)
8. Select “Device Shortcuts”, and press [Enter].

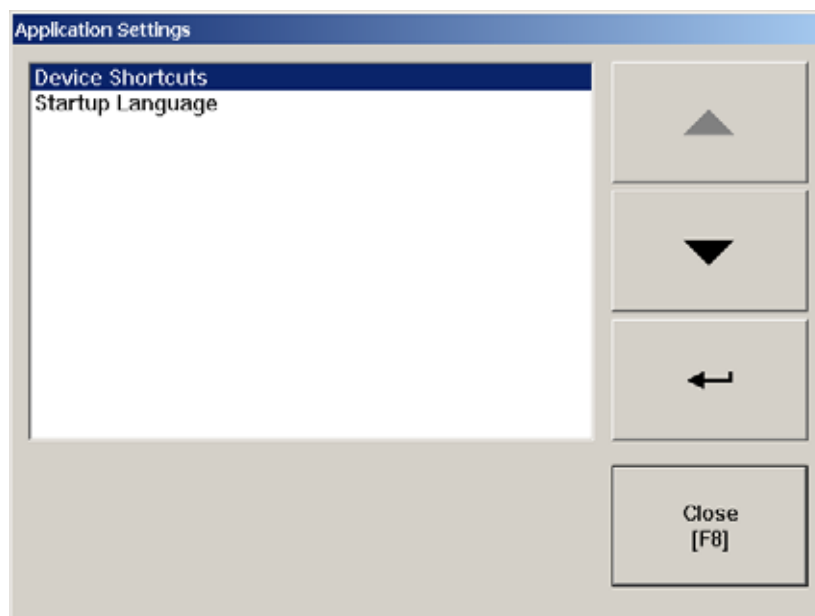

9. Select “AX”, and press [Enter].

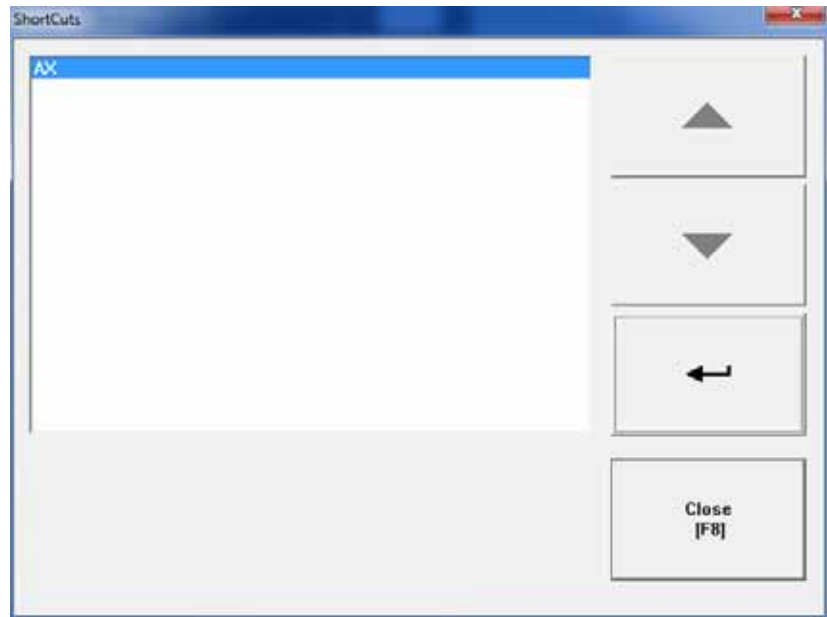

10. Highlight the “MLX200 PLC” processor, and press [OK], and then [Close] two times to get back to the main screen.

11. Press [Run Application] the software shows display without “shadows” when all steps have been completed correctly.

#### NOT COMMUNITCATING PROPERLY



#### SUCCESSFUL COMMUNICATION CONFIGURATION



12. When communication is successful the next time the (.MER) is used only *step 2* and *step 11* will be required.

## Appendix A

### A.1 Rockwell MobileView Support

#### A.1.1 Overview

In 2015 Rockwell introduced their own solution for Teach Pendant hardware, called the MobileView Tethered Operator Terminal product line, referred to as MobileView for the remainder of this document. Yaskawa suggests that all customers and integrators use this product with the MLX200 solution from October 2015 on forward. Yaskawa will end sales of the Fuji pendant and instead recommend that the end user acquire hardware from their Rockwell distributor independently.

Yaskawa will not sell this product directly because most end users already receive favorable pricing from their distributor, due to volume of Rockwell products purchased. Yaskawa would not offer significant value added if we did sell this product and instead would simply be passing along a product with additional mark-up.

Our path forward is to suggest components and show the wiring example in this manual. Customers who are already familiar with PanelView hardware and FactoryTalk View should be familiar with the software provided by Rockwell to complete the integration of a MobileView pendant using the .APA file provided with every MLX200 system.

#### A.1.2 Components

The following chart lists the components which are recommended (purchased separately) for integration with a MLX200 master panel. Other components (relays, fuses, etc) may be substituted if the function is the result.

Description	Vendor	Part Number
MobileView pendant with red E-Stop and Enable switch	Rockwell	2711T-T10R1N1 (another option is 2711T-B10R1K1)
MobileView wiring Accessory	Rockwell	2711T-JBIP20DC
MobileView cable (Other lengths are available)	Rockwell	2711T-5MCABLE
Safety Relays (Qty 2)	Rockwell	440R-N23132
Electric 3.15 Amp Fuse, slow blow	Various	NA
#18 AWG Wire	Various colors and lengths	NA

### A.1.3 Wiring

Always follow appropriate national, local, and state laws and regulations when completing wiring. These diagrams are provided for reference only and imply no warranty or guarantee when followed. Safe practices and common industrial knowledge should always be applied when working around electricity. The following diagrams are for reference only.

Fig. A-1(a): Pendant Interface without Pendant Includes Junction Box and Safety Interface MobileView (For Reference Only)

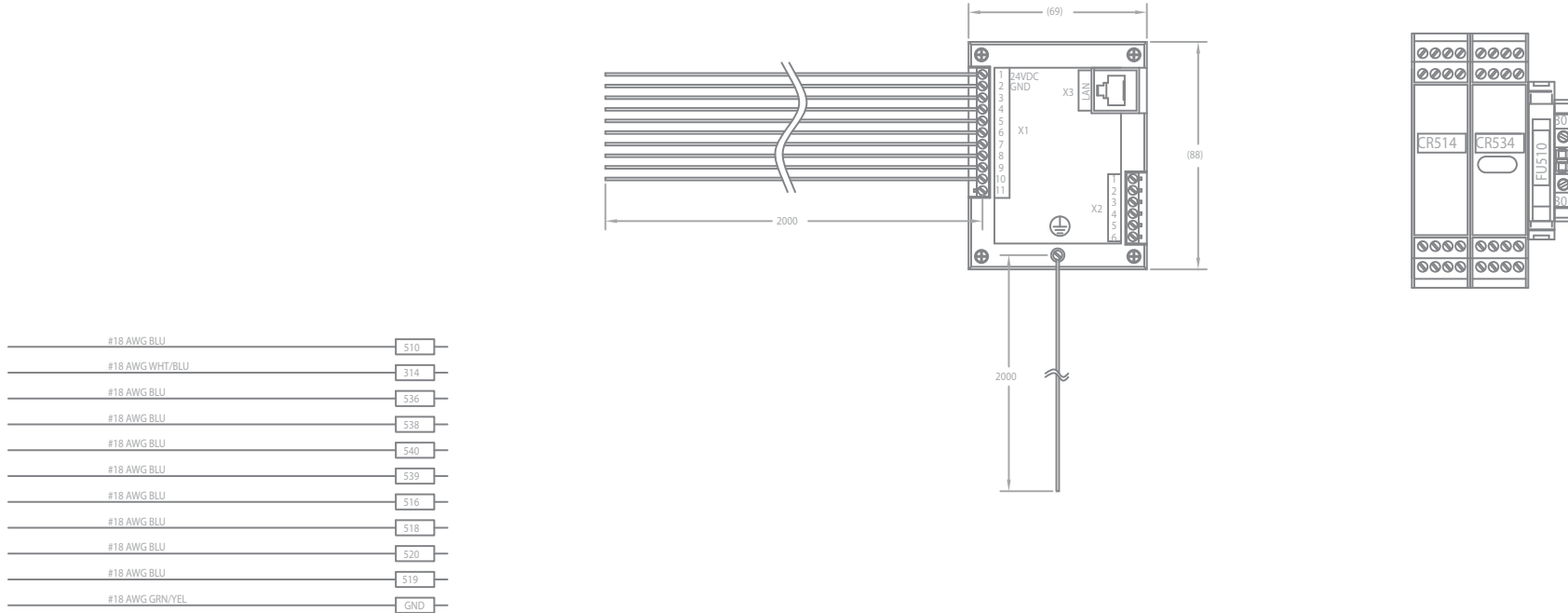

A-2

168283-1CD

Fig. A-1(b): Pendant Interface without Pendant Includes Junction Box and Safety Interface MobileView (For Reference Only)

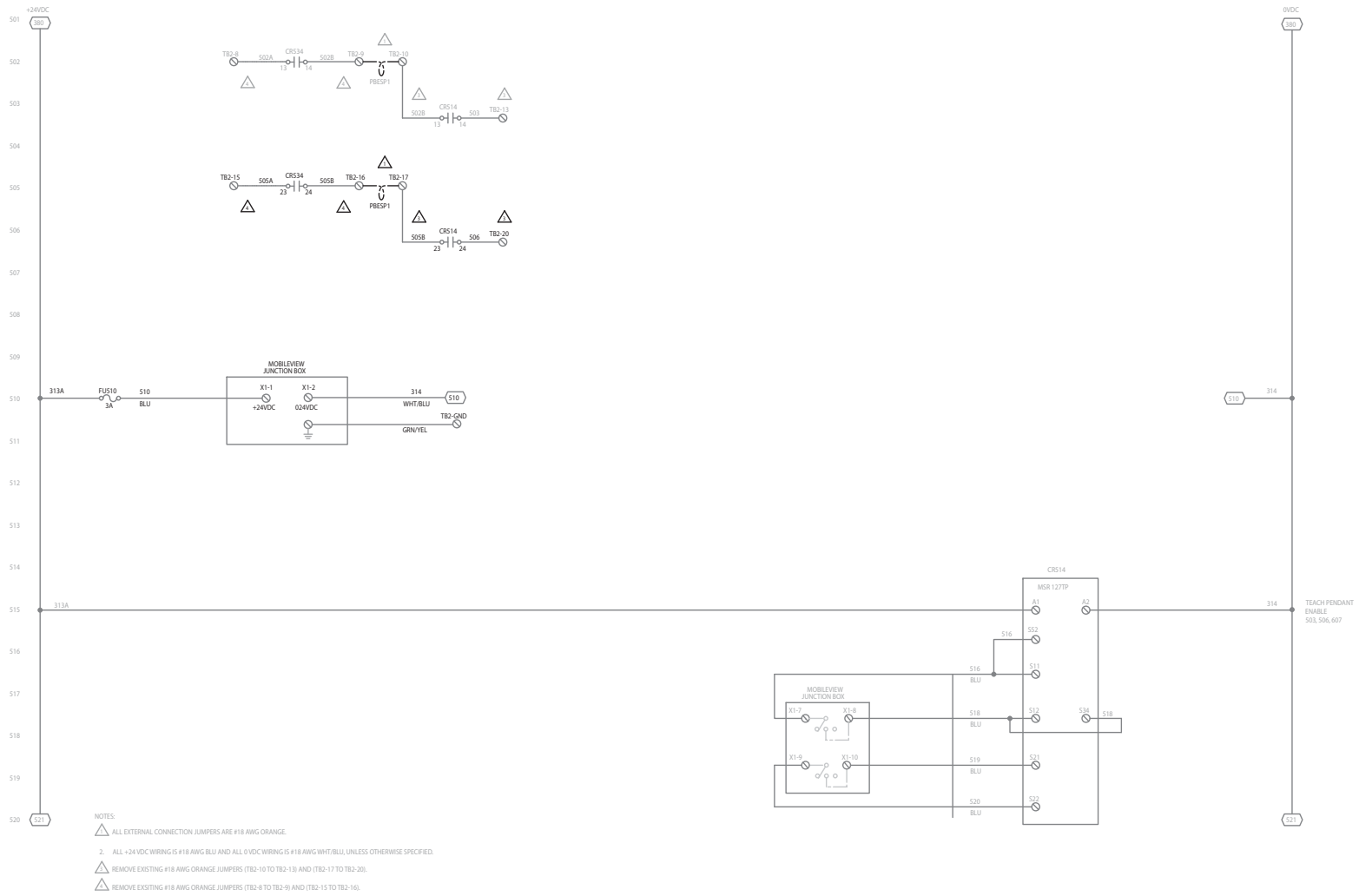

A-3

168283-1CD

Fig. A-1(c): Pendant Interface without Pendant Includes Junction Box and Safety Interface MobileView (For Reference Only)

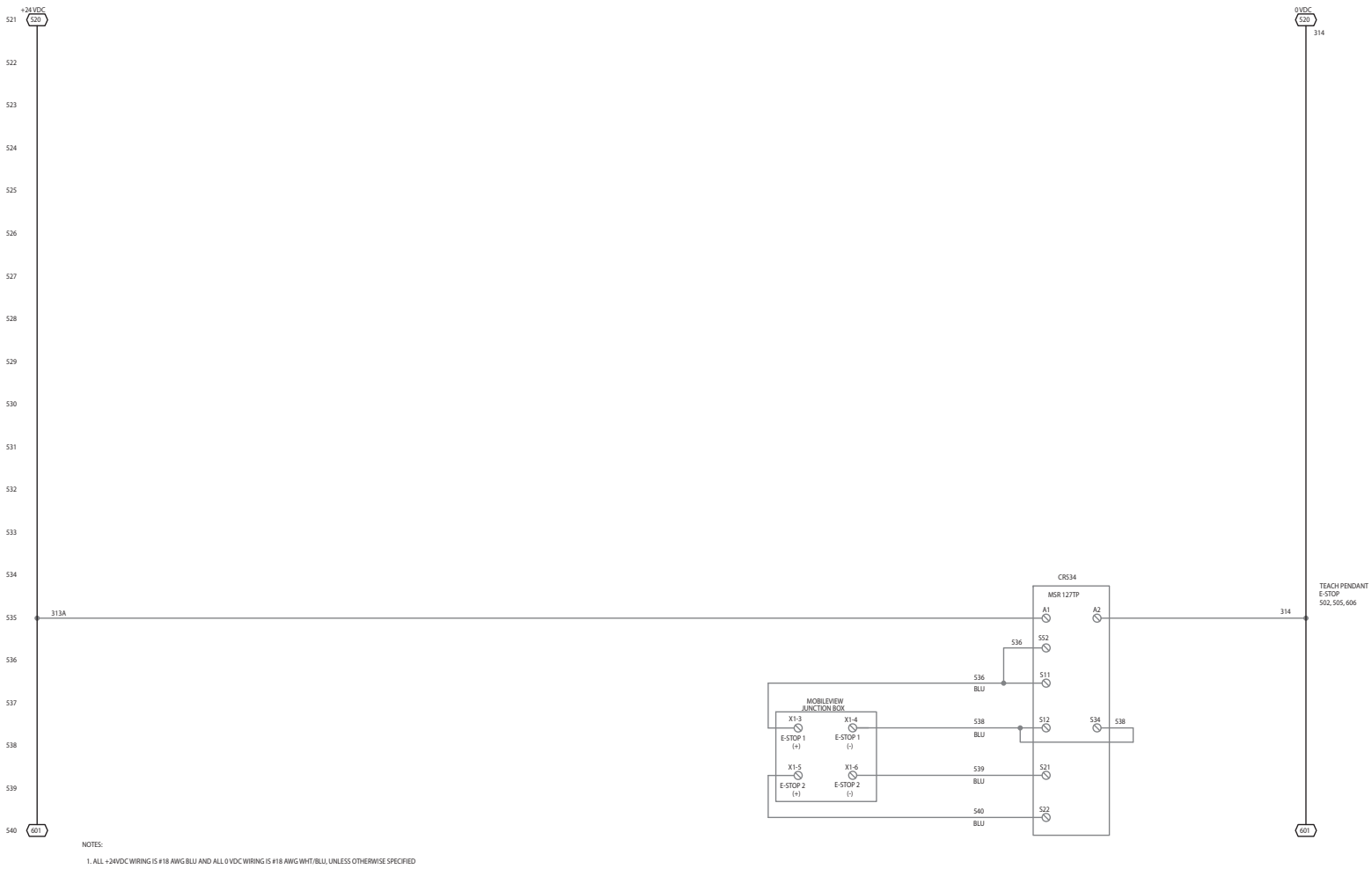

A-4

168283-1CD

Fig. A-1(d): Pendant Interface without Pendant Includes Junction Box and Safety Interface MobileView (For Reference Only)

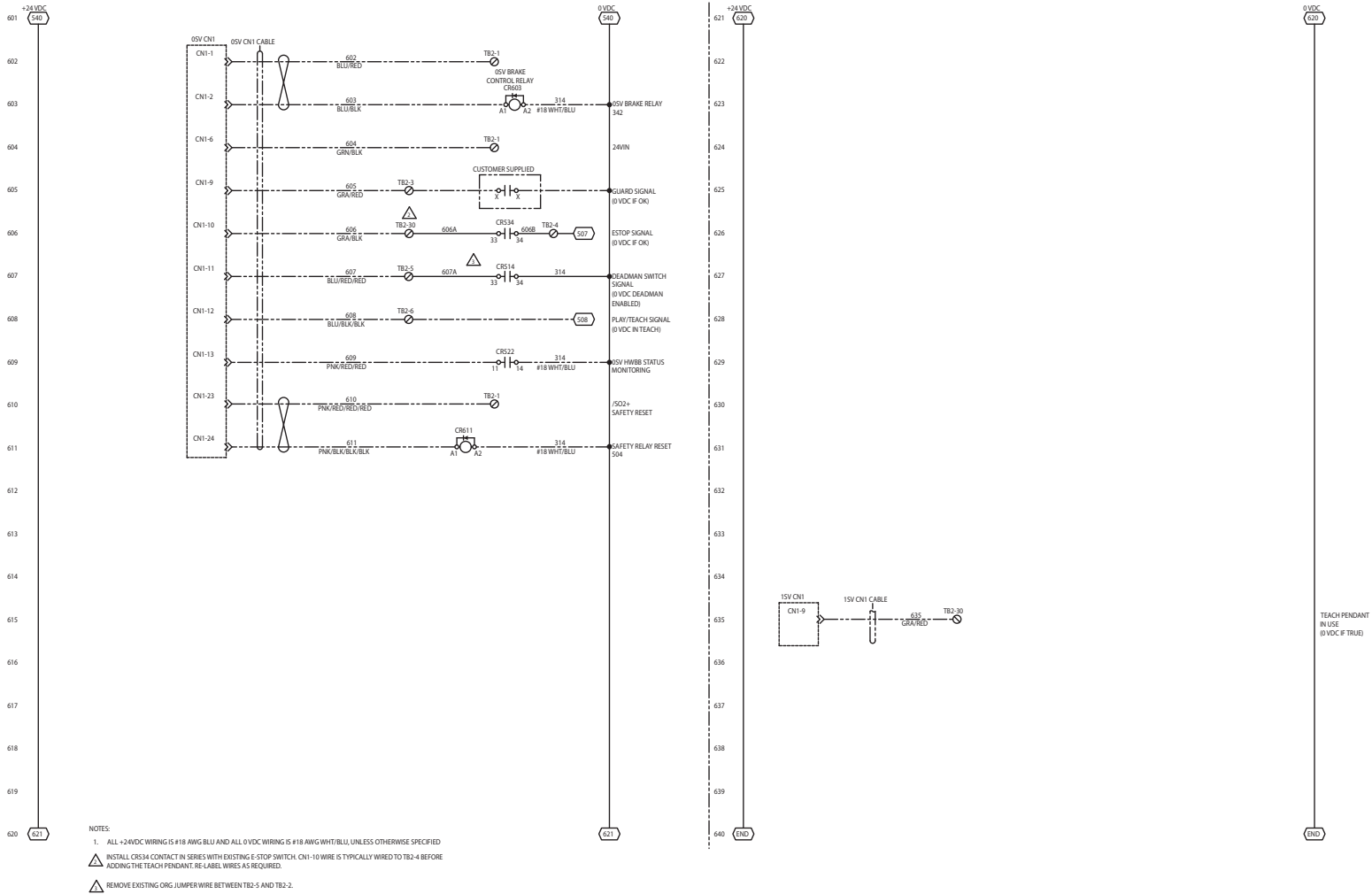

A-5

168283-1CD

**A.1.4 Software****CAUTION**

- End user and integrator must do appropriate testing when deploying .APA files to different devices.

This responsibility lies entirely on the end user and integrator.

The end user and integrator must use caution and do appropriate testing when deploying .APA files to different devices. Test each device to make sure the appropriate access is granted, paying special attention to match the criteria mentioned in this section.

FactoryTalk View project files (.APA) are provided with every MLX200 system. Two sets of files were created to help the integrator enforce “single point of control” requirements. This will be explained after the file names. The files will be named similarly to this: <subject to change>

- MLX200\_HMI\_ForMobileView.APA
  - As the name suggested, software should be installed in the MobileView. This HMI will allow access to all of the jogging and teaching features available. There will be no limitation to screen access when the appropriate user login is used.
- MLX200\_HMI\_ForPCorPanelView.APA
  - Software should be installed in any remote stations, like PanelView HMI displays. This display software will not allow access to Teaching or Jogging functions when the “teach pendant connected jumper” is active. The intent here is enforce “single point of control”, by allowing only one interface to jog the robot. It is critical that the jumper is wired appropriately and that this software is used in PanelView stations!

The default resolution of the MLX200 HMI Project is 640x480. This should be changed to match the desired resolution for the MobileView (1280x800). This can be done under the “Project Settings” in Factory Talk View Studio, after making the change all screens will automatically scale to the new size.

**A.1.5 External References**

Rockwell's website for MobileView:

<http://ab.rockwellautomation.com/Computers/2711T-MobileView-Tethered-Terminals>



# MLX200 HARDWARE INSTALLATION & SOFTWARE UPGRADE

## INSTRUCTIONS

---

### HEAD OFFICE

2-1 Kurosakishiroishi, Yahatanishi-ku, Kitakyushu 806-0004, Japan  
Phone +81-93-645-7703 Fax +81-93-645-7802

YASKAWA America Inc. (Motoman Robotics Division)  
100 Automation Way, Miamisburg, OH 45342, U.S.A.  
Phone +1-937-847-6200 Fax +1-937-847-6277

YASKAWA Europe GmbH (Robotics Division)  
Yaskawastrasse 1, 85391 Allershausen, Germany  
Phone +49-8166-90-100 Fax +49-8166-90-103

YASKAWA Nordic AB  
Bredbandet 1 vån. 3 varvsholmen 392 30 Kalmar, Sweden  
Phone +46-480-417-800 Fax +46-480-417-999

YASKAWA Electric (China) Co., Ltd.  
22/F One Corporate Avenue No.222, Hubin Road, Huangpu District, Shanghai 200021, China  
Phone +86-21-5385-2200 Fax +86-21-5385-3299

YASKAWA SHOUGANG ROBOT Co. Ltd.  
No7 Yongchang North Road, Beijing E&T Development Area, China 100176  
Phone +86-10-6788-2858 Fax +86-10-6788-2878

YASKAWA India Private Ltd. (Robotics Division)  
#426, Udyog Vihar, Phase- IV, Gurgaon, Haryana, India  
Phone +91-124-475-8500 Fax +91-124-475-8542

YASKAWA Electric Korea Co., Ltd  
9F, Kyobo Securities Bldg., 26-4, Yeouido-dong, Yeongdeungpo-gu, Seoul 150-737, Korea  
Phone +82-2-784-7844 Fax +82-2-784-8495

YASKAWA Electric Taiwan Corporation  
12F, No.207, Sec. 3, Beishin Rd., Shindian District, New Taipei City 23143, Taiwan  
Phone +886-2-8913-1333 Fax +886-2-8913-1513

YASKAWA Electric (Singapore) PTE Ltd.  
151 Lorong Chuan, #04-02A, New Tech Park, Singapore 556741  
Phone +65-6282-3003 Fax +65-6289-3003

YASKAWA Electric (Thailand) Co., Ltd.  
59,1st-5th Floor, Flourish Building, Soi Ratchadapisek 18,Ratchadapisek Road,  
Huaykwang, Bangkok 10310, THAILAND  
Phone +66-2-017-0099 Fax +66-2-017-0199

PT. YASKAWA Electric Indonesia  
Secure Building-Gedung B Lantai Dasar & Lantai 1 Jl. Raya Protokol Halim Perdanakusuma,  
Jakarta 13610, Indonesia  
Phone +62-21-2982-6470 Fax +62-21-2982-6741

---

Specifications are subject to change without notice  
for ongoing product modifications and improvements.