

MH5S II MH5LS II

ARC WELDING | ASSEMBLY | CASE PACKING | KITTING
MACHINE TENDING | PART TRANSFER | PICK & PLACE



KEY BENEFITS

Compact and powerful design
Applicable to various industry environments
Highly reliable
Unlimited application possibilities

SPECIFICATIONS

5 kg Payload
Repeatability:
MH5S II: ± 0.02 mm
MH5LS II: ± 0.03 mm
Maximum Reach:
MH5S II: 706 mm
MH5LS II: 895 mm

CONTROLLERS



DX200 FS100 MLX200

- Compact, six-axis robots with 5 kg payload capacity and high axial speeds.
- The MH5S II features a horizontal reach of 706 mm and vertical reach of 1,193 mm; it offers the widest work envelope in its class.
- The MH5LS II features a horizontal reach of 895 mm and vertical reach of 1,560 mm due to its extended lower and upper arm.
- Lightweight and compact base design is ideal for tabletop-, ceiling- or wall-mount installations, saving valuable floor space.
- Slim upper arm design reduces potential interferences. Shortened distance between the B-axis and T-axis enhances carrying capacity with high moments of inertia.
- Internally routed airlines and electrical wires eliminate cable interference, enhance cable life and improve reliability.
- Auxiliary equipment, such as valve packs, can be mounted on upper arm to simplify design and maintain optimal tool performance.
- The MH5S II and MH5LS II robots are applicable to a wide range of tasks - from small parts assembly and machine tending, to high-speed case packing and arc welding.
- Available with several robot controllers tailored to specific application and plant skill set.
- Unlimited application opportunities with options including:
 - NSF-H1 certified food grade lubricants (standard for material handling applications).
 - XP (eXtra Protection) package provides IP65-rated body and IP67-rated wrist.
 - Anti-corrosive paint withstands harsh environments and caustic cleaners in food production environments.

MH5S II | MH5LS II ROBOTS

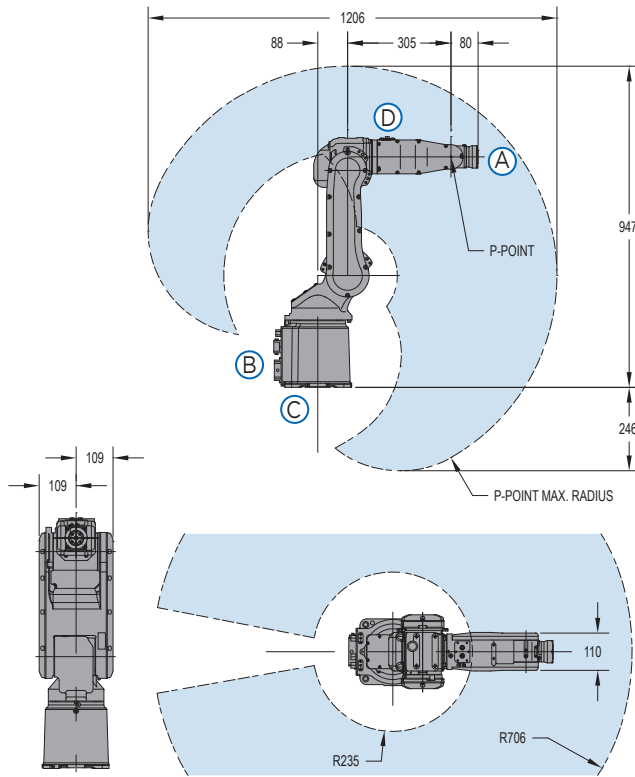

All dimensions are metric (mm) and for reference only. Request detailed drawings for all design/engineering requirements.

VIEW A

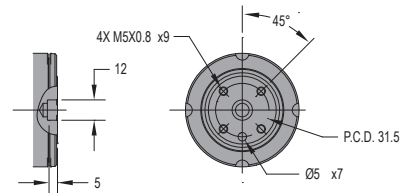

VIEW B

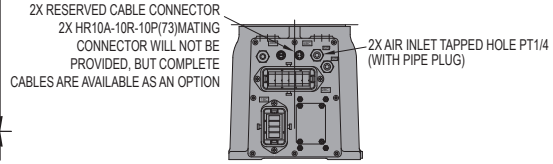

VIEW C

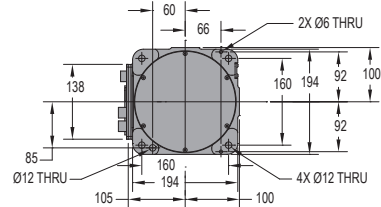

VIEW D

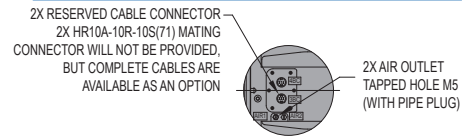

SPECIFICATIONS: MH5S II | MH5LS II

Axes	Maximum motion range [°]		Maximum speed [°/sec.]		Allowable moment [N·m]	Allowable moment of inertia [kg·m ²]	Controlled axes	MH5S II	MH5LS II
	MH5S II	MH5LS II	MH5S II	MH5LS II					
S	±170	±170	376	270	-	-	6	6	
L	-65/+150	-65/+150	350	280	-	-	5	5	
U	-136/+255	-138/+255	400	300	-	-	±0.02	±0.03	
R	±190	±190	450	450	12	0.3	706	895	
B	±135	±135	450	450	12	0.3	1,193	1,560	
T	±360	±360	720	720	7	0.1	IP30	IP30	
							Standard	Standard	
							XP version	Body: IP65; Wrist IP67	Body: IP65; Wrist IP67
							Weight [kg]	27	29
							Power requirements		
							DX200	3-phase; 240/480/575 VAC at 50/60 Hz	3-phase; 240/480/575 VAC at 50/60 Hz
							FS100	1- or 3-phase; 200/230 VAC at 50/60 Hz	1- or 3-phase; 200/230 VAC at 50/60 Hz
							MLX200	3-phase; 200/230 VAC at 50/60 Hz	3-phase; 200/230 VAC at 50/60 Hz
							Power rating [kVA]	1	1

OPTIONS

- Extended length manipulator cables
- Robot risers and base plates
- External axis kits
- Wide variety of fieldbus cards
- Vision systems
- Robot base and upper arm I/O cables
- Blue robots

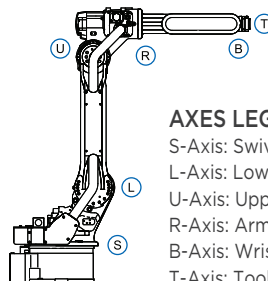

AXES LEGEND

- S-Axis: Swivel Base
- L-Axis: Lower Arm
- U-Axis: Upper Arm
- R-Axis: Arm Roll
- B-Axis: Wrist Bend
- T-Axis: Tool Flange

Yaskawa America, Inc.
Motoman Robotics Division

100 Automation Way
Miamisburg, OH 45342
Tel: 937.847.6200
Fax: 937.847.6277

motoman.com

YASKAWA