

MP2600iec Hardware Manual

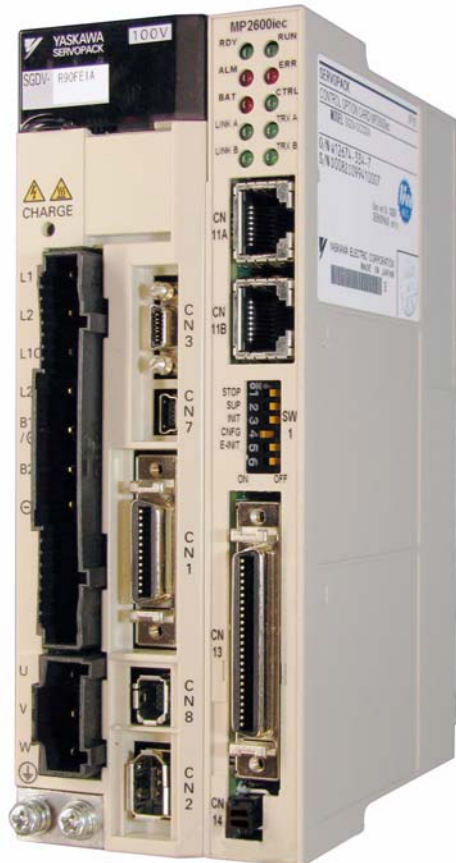

Table of Contents

1 Introduction

| | |
|--------------------------------------|---|
| 1.1 MP2600iec Features - - - - - | 3 |
| 1.2 MP2600iec Appearance- - - - - | 4 |
| 1.3 Model Number Reference - - - - - | 5 |

2 Specifications

| | |
|-------------------------------------------------|---|
| 2.1 General Specifications- - - - - | 7 |
| 2.2 MP2600iec Hardware Specifications - - - - - | 8 |

3 Mechanical Installation

| | |
|--------------------------------------|----|
| 3.1 Mounting Information- - - - - | 9 |
| 3.2 Installation Standards - - - - - | 10 |
| 3.3 Dimensions- - - - - | 11 |

4 Inputs/Outputs

| | |
|-------------------------------------------|----|
| 4.1 CN13 Connection Diagram - - - - - | 13 |
| 4.2 CN13 Connection Description - - - - - | 14 |
| 4.3 External Encoder Interface - - - - - | 15 |
| 4.4 Controller Digital I/O - - - - - | 16 |
| 4.5 Sigma-5 I/O - - - - - | 18 |
| 4.6 Analog I/O - - - - - | 19 |

5 DIP Switches

| | |
|-------------------------------|----|
| 5.1 Switch Settings - - - - - | 21 |
|-------------------------------|----|

6 LED Outputs - - - - - 23

7 Battery

| | |
|-----------------------------------|----|
| 7.1 Battery Installation- - - - - | 25 |
|-----------------------------------|----|

8 Ethernet

8.1 Connectivity Information- - - - - 27

8.2 Ethernet Connector Details- - - - - 27

8.3 Ethernet Cable - - - - - 28

8.4 Ethernet Connection Examples- - - - - 28

9 Cable Diagrams

9.1 CBK-U-MP2B-xx (Terminal Block-Controller) - - - - - 31

9.2 CFC-U-MP2B-xx (Flying Lead-Controller) - - - - - 32

9.3 SBK-U-VBA-xx (Terminal Block-Servo Amp) - - - - - 33

9.4 JZSP-CSI02-x-E (Flying Lead-Servo Amp) - - - - - 34

10 Firmware Upgrade Procedure - - - - - 35

11 EMC Installation Conditions - - - - - 37

1 Introduction

1.1 MP2600iec Features

MP2600iec is a single-axis machine controller option card that is attached to a Sigma-5 servo amplifier. The servo amplifier and controller are factory assembled, providing a compact, all-in-one servo/controller package with the following features:

- PLCopen for Motion Control, including indexing, camming, gearing, and servo parameter maintenance capability.
- Sigma-5 self-tuning, anti-vibration, and other high performance, easy-to-implement servo control features
- Ethernet (100Mbps) Auto crossover switching
 - EtherNet/IP
 - Modbus TCP
 - Allows high-speed communications with MotionWorks IEC
 - Enables communication with the application program by using a touch panel
 - Enables communication with the application program from another controller
- Combined Amplifier/Controller I/O features
 - 15 digital inputs
 - 11 digital outputs
 - 1 analog input
 - 1 analog output
 - 1 external encoder (quadrature, pulse + direction, up/down)
 - 1 external encoder latch

1.2 MP2600iec Appearance

The following figure shows the external appearance of the MP2600iec controller (Note: The servo amplifier is not shown).

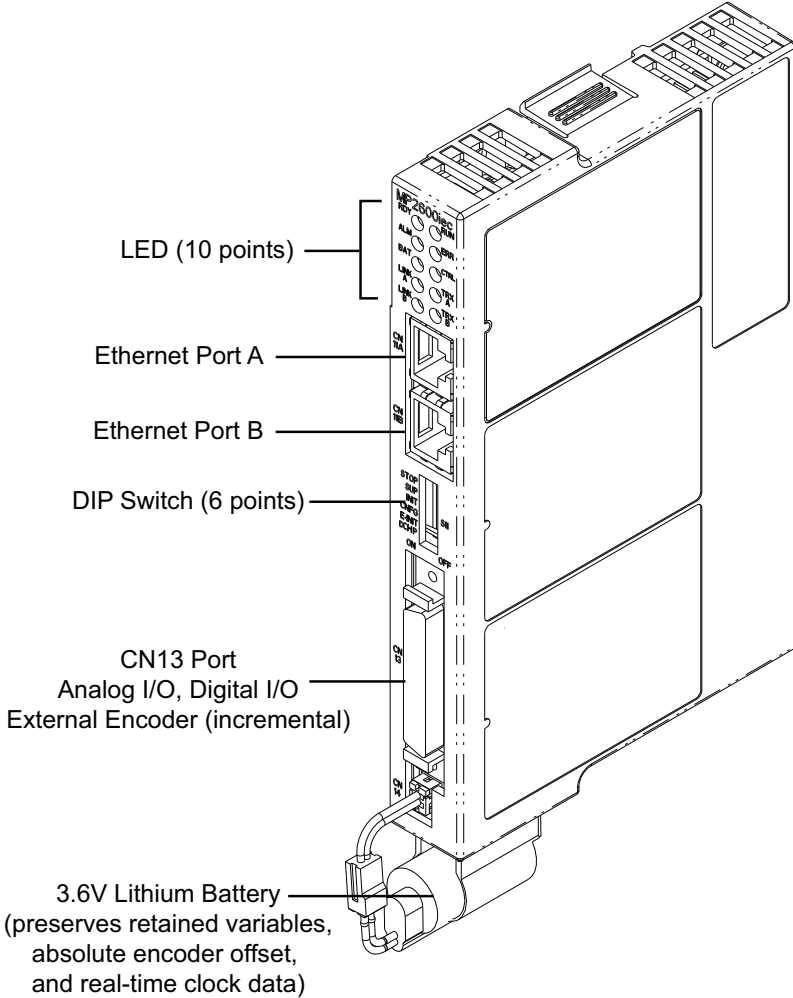

1.3 Model Number Reference

1.3.1 Model Number Designation

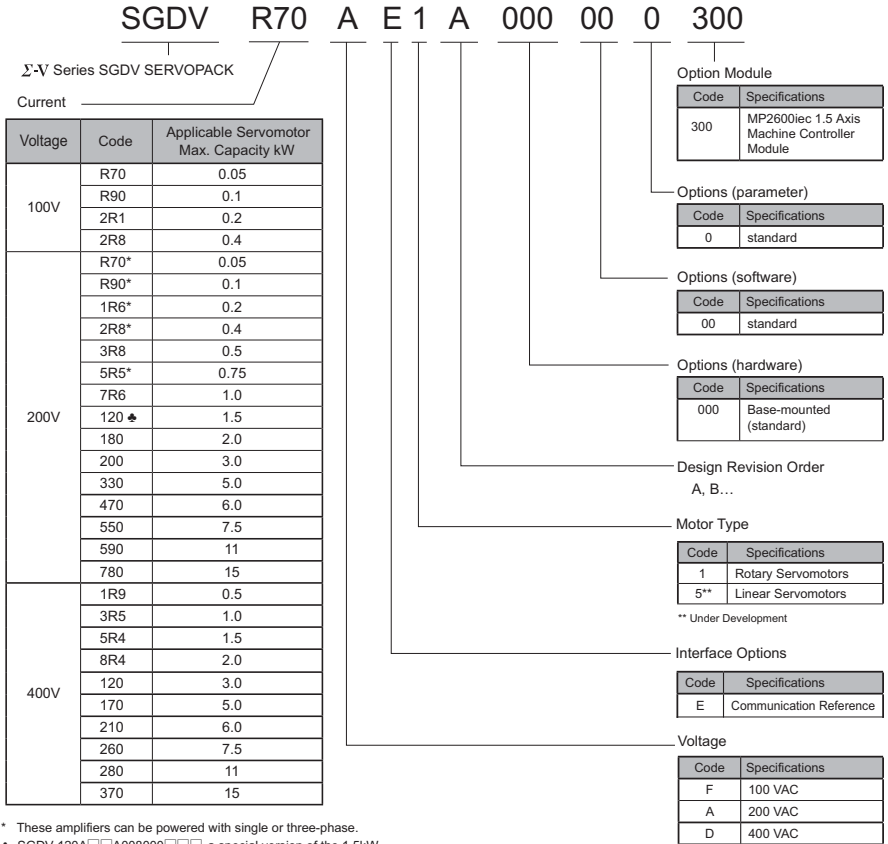

1.3 Model Number Reference

1.3.2 Accessory Model Numbers

1.3.2 Accessory Model Numbers

| System Components | | | |
|--------------------|------------------------------------------------------|----------------|--------------------------------------------------------------------|
| Type | Model | Part Number | Note |
| Accessories/Cables | Battery | JZSP-BA01 | Replacement |
| | Battery Holder Kit | SGDV-OZC02A | Replacement (does not include battery) |
| | CN13 (MP2600iec) Terminal Block Conversion Kit | CBK-U-MP2Bxx | xx denotes cable length (m) A5 = 0.5 01 = 1 03 = 3 |
| | CN13 (MP2600iec) (Flying Leads) | CFC-U-MP2Bxx | |
| | CN1 (Servo Amp) Terminal Block Conversion Kit | SBK-U-MP2Bxx | |
| | CN1 (Servo Amp) Cable (Flying Leads) | JZSP-CSI02-x-E | x denotes cable length (m) A = 1 B = 2 C = 3 |
| Communication | Ethernet Cable | N/A | Use commonly available shielded Ethernet cable |
| Software | MotionWorks IEC Express | PDE-U-IE□Sx | □ denotes MotionWorks IEC Version C = 1 2 = 2 |
| | MotionWorks IEC Pro | PDE-U-IE□Px | x denotes number of software licenses A = 1 B = 5 C = 10 |
| | OPC Server | PDE-U-OPCPx | x denotes number of software licenses A = 1 B = 5 C = 10 D = 20 |

2 Specifications

2.1 General Specifications

| Item | | Specifications |
|---------------------------------|---------------------------------------|----------------------------------------------------------------------------------------------------------------------------------------------------------------------------------------------------------------------------------------------------------------------------------------------------|
| Environmental Conditions | Ambient Operating Temperature | 0 to 55°C |
| | Ambient Storage Temperature | -20°C to +85°C |
| | Ambient Operating Humidity | 90% RH or less (with no condensation) |
| | Ambient Storage Humidity | 90% RH or less (with no condensation) |
| | Protection Class/ Pollution Degree | Protection class: IP10, Pollution degree: 2 An environment that satisfies the following conditions. <ul style="list-style-type: none"> • Free of corrosive or explosive gases • Free of exposure to water, oil or chemicals • Free of dust, salts or iron dust |
| | Operating Altitude | 1,000 m above sea level or lower |
| Mechanical Operating Conditions | Vibration Resistance | 4.9 m/s ² |
| | Shock Resistance | 19.6 m/s ² |
| | Others | Free of static electricity, strong electromagnetic fields, magnetic fields or exposure to radioactivity |

2.2 MP2600iec Hardware Specifications

| Item | | Specification | | |
|----------------------------------------|------------------------|----------------------------------------------------------------------------------------|--------------------------------------------------------------------------|--------------------------------------------------------------------------------------------------------------------------------------------------------------------------------------------------------------------------------------------------------------------------------------------------------------------------|
| CPU | | 200 MHz, 32 bit, ARM 9 | | |
| Memory | SDRAM | | 32 MB | |
| | SRAM | | 512 kB with battery backup | |
| | Flash | | 4 MB flash. Code and parameter storage. | |
| Operator interface | | LED | 10 LEDs (red and green - operating mode, communication and error status) | |
| | | User Configuration | 6x DIP switch (operating mode and communication configuration) | |
| User I/O | Controller Side (CN13) | Network | | 2x 100baseTX Ethernet |
| | | Digital input | | 8 programmable inputs |
| | | Digital output | | 8 programmable outputs |
| | | Analog input | | 1 ch., +/- 10V, 16 bit |
| | | Analog output | | 1 ch., +/- 10V, 16 bit |
| | | Pulse Counter | | RS-422-compatible pulse counter input (quadrature, pulse and direction, and up/down counter modes) with 5, 12, or 24V position latch input |
| | Servo-Side (CN1) | Sequence Input | Allocated* | Number of Inputs: 7 |
| | | | | Functions: The signal allocation and positive/negative logic can be modified. Forward run prohibited (/P-OT), reverse run prohibited (/N-OT), forward torque limit (/P-CL), reverse torque limit (/N-CL), general-purpose input signal (/SI0 to /SI6) |
| | | Sequence Output | Fixed | Servo Alarm (ALM) |
| | | | | Number of Outputs: 3 |
| | | | Allocated* | Functions: The signal allocation and positive/negative logic can be modified. Positioning completion (/COIN), speed coincidence detection (/V-CMP), servomotor rotation detection (/TGON), servo ready (/S-RDY), torque limit detection (/CLT), speed limit detection (/VLT), brake (/BK), warning (/WARN), near (/NEAR) |
| | | | | |
| Network capability | | OPC (Client and Server required) | | |
| | | EtherNet/IP | | |
| | | Modbus/TCP | | |
| Programming standards | | IEC61131-3/PLCopen | | |
| Diagnostic and configuration interface | | Web interface | | |
| Motion control performance | | 1 controlled axis and one external position input at a trajectory update rate of 1 kHz | | |
| Servo-Side Safety Functions | | Input | /HWBB1, /HWBB2: Baseblock signal for power module | |
| | | Output | EDM1: Status monitor (fixed output) of built-in safety circuit | |

* Allocated I/O can also be used as programmable I/O if the output functions are disabled.

3 Mechanical Installation

3.1 Mounting Information

The MP2600iec controller is pre-assembled to the Sigma-5 servo amplifier by the factory.

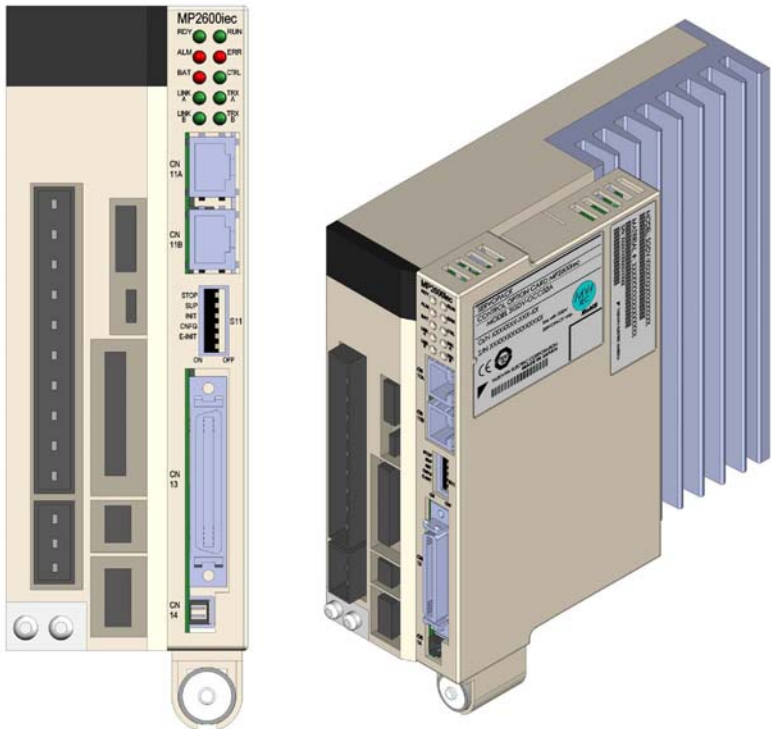

3.2 Installation Standards

The servo amplifier must be installed in a fully enclosed metal control panel. Observe the standards for mounting servo amplifiers in control panels, including those for the mounting servo amplifiers side by side in one control panel as shown in the following illustration.

- **Servo Amplifier Mounting Orientation**
Mount the servo amplifier vertically to the wall, with the front panel (the side with the panel operator display) facing out.
- **Cooling**
Refer to the following diagram and leave sufficient space for cooling by fans and natural convection.
- **Mounting Servo Amplifiers Side by Side in a Control Panel**

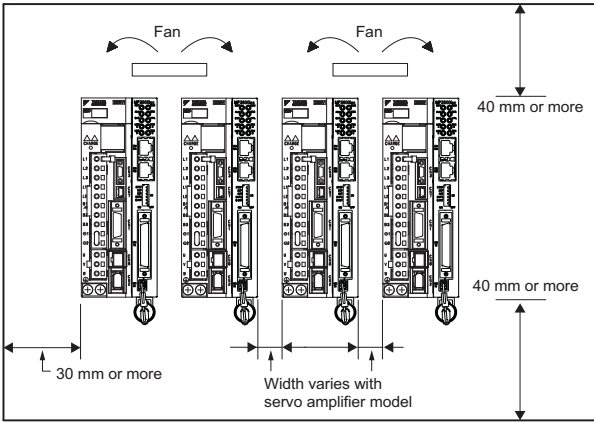

Leave sufficient space on each side and at the top and the bottom of each servo amplifier. The width on each side varies in accordance with the models of the servo amplifiers used.

| Servo Amplifier Model SGDV- | Side | | Top and bottom |
|------------------------------------------------------------------------------------------------------------|---------------|---------------|----------------|
| | Left | Right | |
| R70F, R90F, 2R1F, R70A, R90A, 1R6A, 2R8A | 1 mm or more | | 40 mm or more |
| 2R8F, 3R8A, 5R5A, 7R6A | 1 mm or more | 10 mm or more | |
| 120A, 180A, 200A, 330A, 470A, 550A, 590A, 780A, 1R9D, 3R5D, 5R4D, 8R4D, 120D, 170D, 210D, 260D, 280D, 370D | 10 mm or more | | |

Also install cooling fans above the servo amplifiers to disperse local pockets of warmer air around the servo amplifiers.

- **Inside the Control Panel**
The conditions inside the control panel should be the same as the environmental conditions of the servo amplifier. Refer to the environmental conditions in 2.1 *General Specifications*
- **During Operation**
Do not touch the connectors or IO cables during operation if the panel door is open.

3.3 Dimensions

3.3.1 MP2600iec Controller

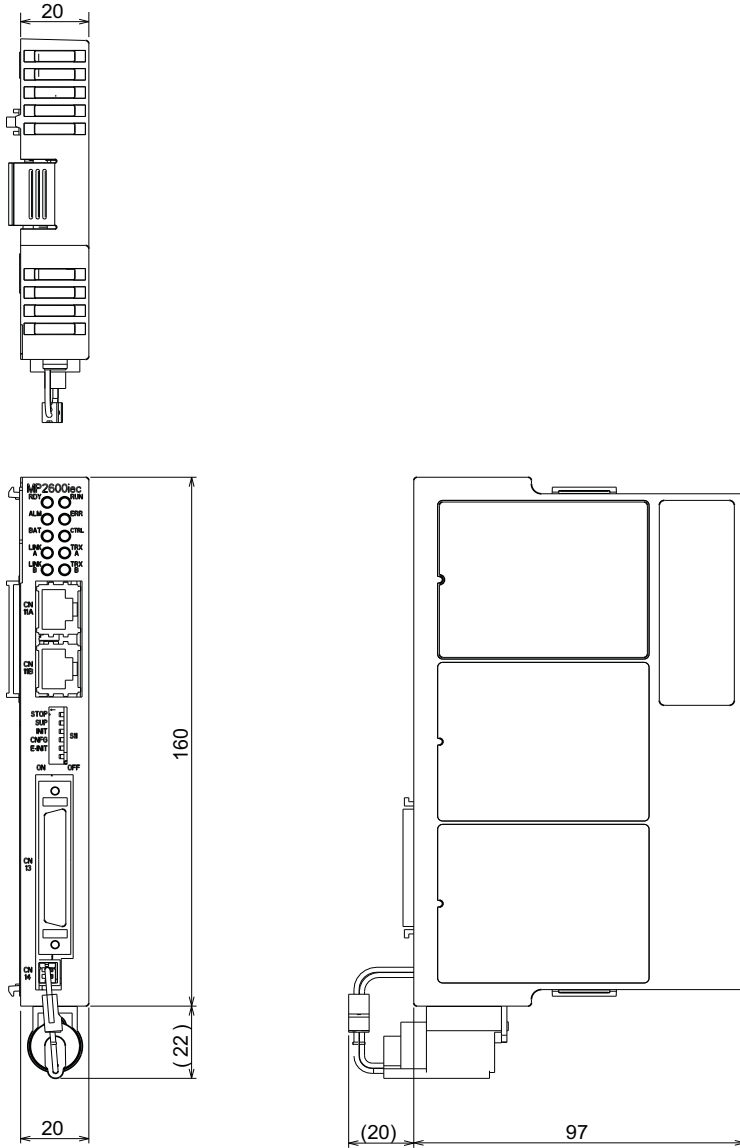

Dimensions in mm.

3.3 Dimensions

3.3.1 MP2600iec Controller

This page left intentionally blank

4 Inputs/Outputs

4.1 CN13 Connection Diagram

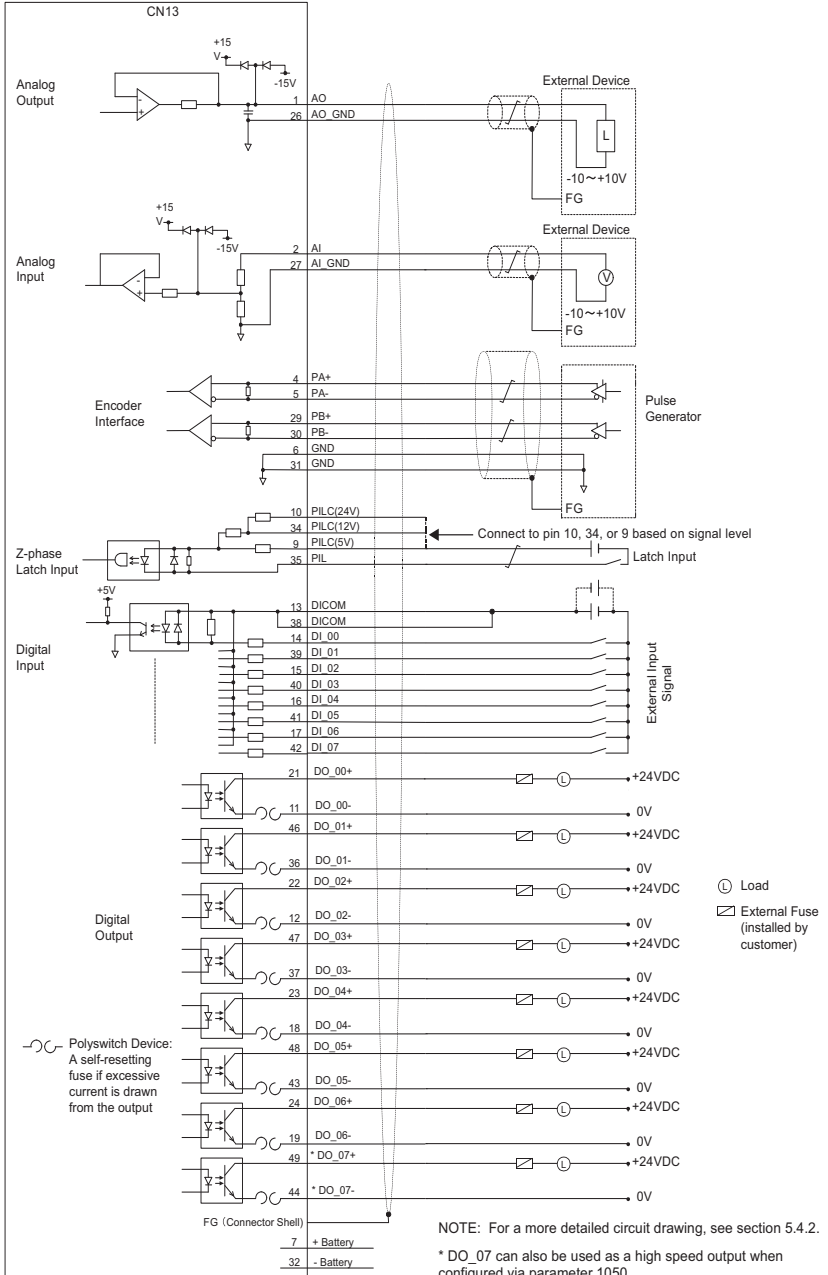

4.2 CN13 Connection Description

Numerical

| CN 13 Pin | Code | Description |
|-----------|--------|-----------------------------------|
| 1 | AO | Analog Output |
| 2 | AI | Analog Input |
| 3 | n/c | no connection |
| 4 | PA+ | Encoder A phase + |
| 5 | PA- | Encoder A phase - |
| 6 | GND | Encoder ground |
| 7 | BAT + | SRAM Positive Battery input |
| 8 | n/c | no connection |
| 9 | PILC | PC+ / External Encoder Latch +5V |
| 10 | PILC | PC+ / External Encoder Latch +24V |
| 11 | DO 00- | Digital Output 0 - |
| 12 | DO 02- | Digital Output 2 - |
| 13 | DICOM | Digital Input Common |
| 14 | DI 00 | Digital Input 0 |
| 15 | DI 02 | Digital Input 2 |
| 16 | DI 04 | Digital Input 4 |
| 17 | DI 06 | Digital Input 6 |
| 18 | DO 04- | Digital Output 4 - |
| 19 | DO 06- | Digital Output 6 - |
| 20 | n/c | no connection |
| 21 | DO 00+ | Digital Output 0 + |
| 22 | DO 02+ | Digital Output 2 + |
| 23 | DO 04+ | Digital Output 4 + |
| 24 | DO 06+ | Digital Output 6 + |
| 25 | n/c | no connection |
| 26 | AO GND | Analog Output Ground |
| 27 | AI GND | Analog Input Ground |
| 28 | n/c | no connection |
| 29 | PB+ | Encoder B phase + |
| 30 | PB- | Encoder B phase - |
| 31 | GND | Encoder ground |
| 32 | BAT - | SRAM Negative Battery input |
| 33 | n/c | no connection |
| 34 | PILC | PC+ / External Encoder Latch +12V |
| 35 | PIL | PC- / External Encoder Latch |
| 36 | DO 01- | Digital Output 1 - |
| 37 | DO 03- | Digital Output 3 - |
| 38 | DICOM | Digital Input Common |
| 39 | DI 01 | Digital Input 1 |
| 40 | DI 03 | Digital Input 3 |
| 41 | DI 05 | Digital Input 5 |
| 42 | DI 07 | Digital Input 7 |
| 43 | DO 05- | Digital Output 5 - |
| 44 | DO 07- | Digital Output 7 - |
| 45 | n/c | no connection |
| 46 | DO 01+ | Digital Output 1 + |
| 47 | DO 03+ | Digital Output 3 + |
| 48 | DO 05+ | Digital Output 5 + |
| 49 | DO 07+ | Digital Output 7 + |
| 50 | n/c | no connection |

Alphabetical

| Description | Code | CN 13 Pin |
|----------------------------------|--------|-----------|
| Analog Input | AI | 2 |
| Analog Input Ground | AI GND | 27 |
| Analog Output | AO | 1 |
| Analog Output Ground | AO GND | 26 |
| Digital Input 0 | DI 00 | 14 |
| Digital Input 1 | DI 01 | 39 |
| Digital Input 2 | DI 02 | 15 |
| Digital Input 3 | DI 03 | 40 |
| Digital Input 4 | DI 04 | 16 |
| Digital Input 5 | DI 05 | 41 |
| Digital Input 6 | DI 06 | 17 |
| Digital Input 7 | DI 07 | 42 |
| Digital Input Common | DICOM | 13 |
| Digital Input Common | DICOM | 38 |
| Digital Output 0 - | DO 00- | 11 |
| Digital Output 0 + | DO 00+ | 21 |
| Digital Output 1 - | DO 01- | 36 |
| Digital Output 1 + | DO 01+ | 46 |
| Digital Output 2 - | DO 02- | 12 |
| Digital Output 2 + | DO 02+ | 22 |
| Digital Output 3 - | DO 03- | 37 |
| Digital Output 3 + | DO 03+ | 47 |
| Digital Output 4 - | DO 04- | 18 |
| Digital Output 4 + | DO 04+ | 23 |
| Digital Output 5 - | DO 05- | 43 |
| Digital Output 5 + | DO 05+ | 48 |
| Digital Output 6 - | DO 06- | 19 |
| Digital Output 6 + | DO 06+ | 24 |
| Digital Output 7 - | DO 07- | 44 |
| Digital Output 7 + | DO 07+ | 49 |
| Encoder A phase - | PA- | 5 |
| Encoder A phase + | PA+ | 4 |
| Encoder B phase - | PB- | 30 |
| Encoder B phase + | PB+ | 29 |
| Encoder ground | GND | 6 |
| Encoder ground | GND | 31 |
| no connection | n/c | 3 |
| no connection | n/c | 8 |
| no connection | n/c | 20 |
| no connection | n/c | 25 |
| no connection | n/c | 28 |
| no connection | n/c | 33 |
| no connection | n/c | 45 |
| no connection | n/c | 50 |
| PC- / External Encoder Latch | PIL | 35 |
| PC+ / External Encoder Latch+12V | PILC | 34 |
| PC+ / External Encoder Latch+24V | PILC | 10 |
| PC+ / External Encoder Latch +5V | PILC | 9 |
| SRAM Negative Battery input | BAT - | 32 |
| SRAM Positive Battery input | BAT + | 7 |

Note: DO_07 can also be used as a high speed output when configured via parameter 1050. See the PLCopen Plus Axis Parameters for more details.

4.3 External Encoder Interface

| Item | Specification |
|--------------------|-------------------------------------------------------------------------------------------------------------------------------------------------------------------------------------------------------------------------------------------|
| Number of channels | One channel (Phase A, Phase B, Index pulse) |
| Input circuit | Phase A & B: 5V differential input (RS-422 compatible), non-insulated. Maximum frequency 4MHz. Index pulse: 5V/12V/24V photo coupler input. Maximum frequency 500kHz (pre-quadrature). This signal is used for external encoder latch. |
| Counter modes | Quadrature, pulse and direction, up/down |
| Latch input | Latch on index pulse or DI_01 digital input. Hardware latency: 5μs or less (index pulse) |

Two RS-422 compatible inputs are provided for encoder phases A and B. One position latch input which supports a 5V, 12V, or 24V digital input signal is provided.

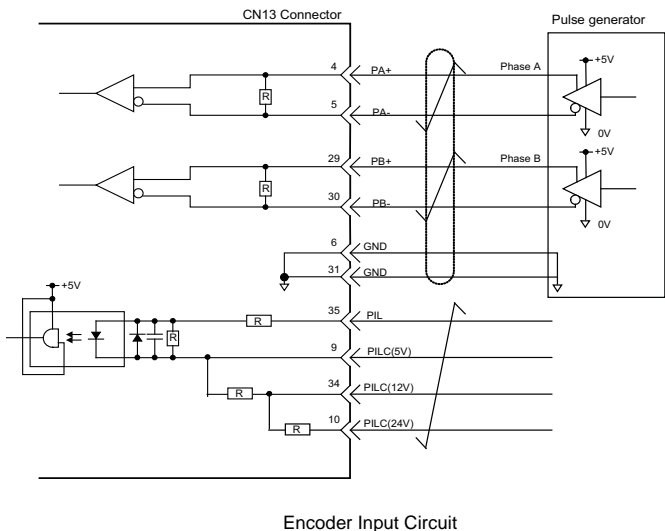

4.4 Controller Digital I/O

4.4.1 Inputs

- 8 general purpose
- Optically isolated
- 24 V @ 5 mA
- Entire bank is configurable as either current sinking or sourcing via connection of common

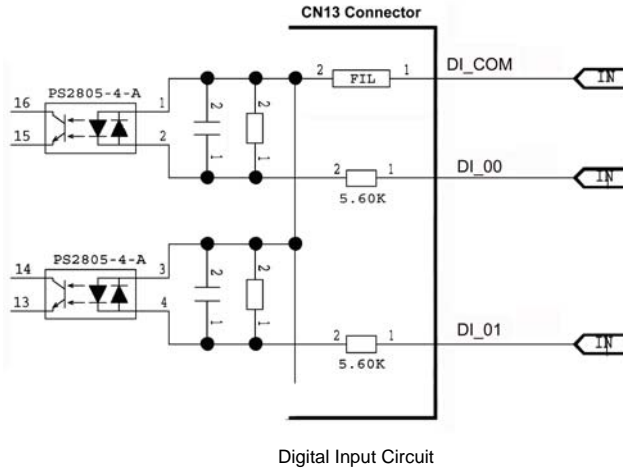

To configure all controller inputs as sinking, wire +24VDC to pins 13 and 38. To configure all controller inputs as sourcing, wire 0VDC to pins 13 and 38. Refer to diagram in Section 5.1.

4.4.2 Outputs

- 8 general purpose
- Optically isolated
- 24 V @ 50 mA
- Current source or sink (connection to both emitter and collector are provided)
- High speed digital output feature can set DO_07 within 13 μ s of passing a specified encoder position. See Axis Parameters in the PLCopen Plus Function Block Manual to configure.

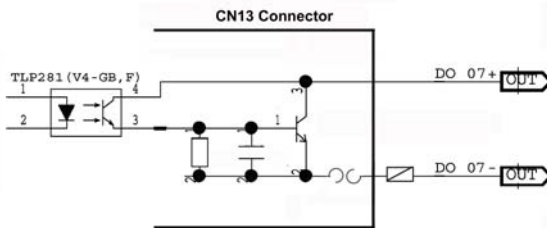

Digital Output Circuit

Connection Examples of Output Circuits

- Relay Circuit Example

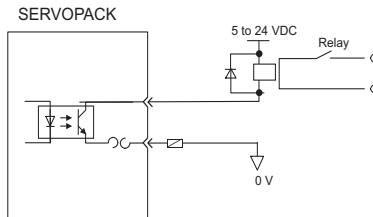

- Line Receiver Circuit Example

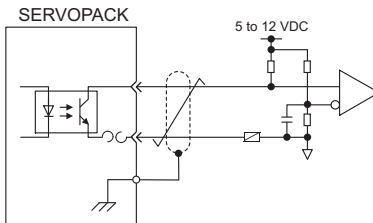

4.5 Sigma-5 I/O

The Sigma-5 includes seven digital inputs and three digital outputs that can be monitored and controlled by the MP2600ieC.

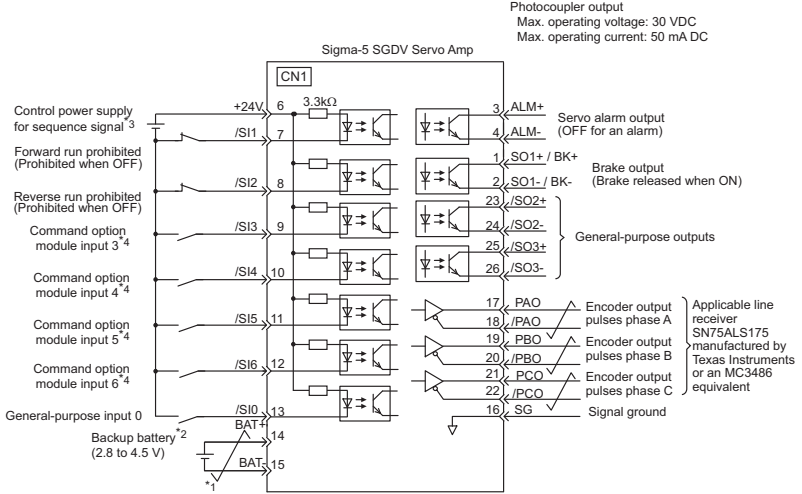

4.6 Analog I/O

4.6.1 Analog Input

| Item | | Specification |
|--------------------------|---------------|------------------------------------------------|
| Analog input range | | -10V ~ +10V |
| Number of input channels | | 1 |
| Electrical isolation | | None |
| Absolute maximum input | | $\pm 15V$ |
| Input Impedance | | 20k Ω |
| Resolution | | 16 bit |
| Accuracy | 25°C | $\pm 0.1\%$ ($\pm 10mV$) |
| | 0 ~ 55°C | $\pm 0.3\%$ ($\pm 30mV$) |
| Input filter | Time constant | $\tau = 130\mu s$ (63.2% rise time) |
| | Delay time | 1ms maximum (for full-range -10V to +10V slew) |
| Conversion time | | 50 μs |

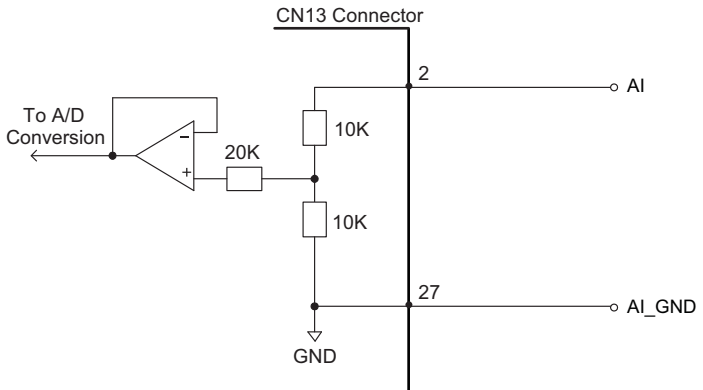

Analog Input Circuit

4.6.2 Analog Output

| Item | | Specification |
|---------------------------|----------|------------------------------------|
| Analog output range | | -10V ~ +10V |
| Number of output channels | | 1 |
| Electrical isolation | | None |
| Maximum load current | | $\pm 5\text{mA}$ |
| Resolution | | 16 bit |
| Accuracy | 25°C | $\pm 0.45\%$ ($\pm 45\text{mV}$) |
| | 0 ~ 55°C | $\pm 0.60\%$ ($\pm 60\text{mV}$) |
| Output delay time | | less than 1ms |

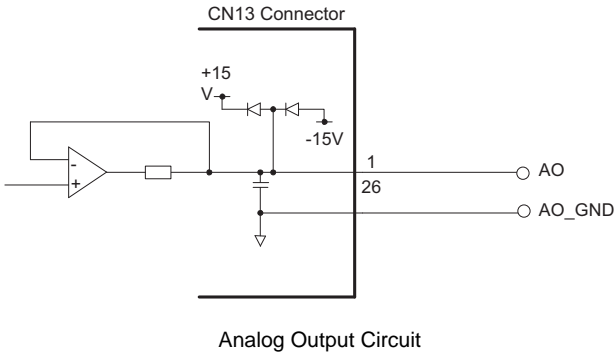

5 DIP Switches

5.1 Switch Settings

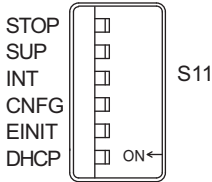

| Switch | Name | Setting | Operating Mode | Setting for Normal Operation | Details |
|--------|--------|---------|------------------------------------------------------------------------------------|------------------------------|-----------------------------------------------------------------------------------------------------------------------------------------------------------------------------------------------------------------------------------|
| 1 | STOP | ON | User program execution inhibited | OFF | Inhibits user program execution |
| | | OFF | Normal operation | | |
| 2 | SUP | ON | Firmware programming mode | OFF | Enables controller firmware programming. (See Section 11) |
| | | OFF | Normal operation | | |
| 3 | INIT | ON | SRAM/clock initialization and configuration bypass mode | OFF | Set to ON to bypass the stored configuration (e.g. in case of a configuration problem that prevents controller startup) or to initialize the SRAM contents and clock settings after backup power has been lost (See Section 7.1). |
| | | OFF | Normal operation | | |
| 4 | CNFG | ON | Normal operation | ON | Always set to ON |
| | | OFF | Do not set (reserved for future use) | | |
| 5 | E-INIT | ON | Force Ethernet address setting for Port A to 192.168.1.1 and Port B to 192.168.2.1 | OFF | Enables use of the default Ethernet addresses |
| | | OFF | Normal Operation | | |
| 6 | DHCP | ON | DHCP-configured IP settings | OFF | Enables use of DHCP for IP setting configuration |
| | | OFF | Manually-configured IP settings | | |

This page left intentionally blank

6 LED Outputs

The following table shows the indicators that show the operating status of the controller and error information.

| | Indicator | Color | Status |
|------------------------------------------------------------------------------------|-----------|-------|---------------------------------------------------------------|
| RDY ○ ○ RUN ALM ○ ○ ERR BAT ○ ○ CTRL LINK A ○ ○ TRX A LINK B ○ ○ TRX B | RDY | Green | Lit during normal operation. |
| | RUN | Green | Lit during execution of user program. |
| | ALM | Red | Lit when alarm occurs. |
| | ERR | Red | Lit when malfunction occurs. |
| | CTRL | Green | Lit when option card is communicating to the servo amplifier. |
| | BAT | Red | Lit during battery alarm. |
| | TRX A | Green | Lit during Ethernet CN11A activity. |
| | LINK A | Green | Lit during Ethernet CN11A link up. |
| | TRX B | Green | Lit during Ethernet CN11B activity. |
| | LINK B | Green | Lit during Ethernet CN11B link up. |

This page left intentionally blank

7 Battery

7.1 Battery Installation

A 3.6V lithium battery must be used to retain SRAM data in the controller when the power is off. SRAM will last for one hour without the battery connected. The battery power can be applied through the battery connector (CN14), or through the I/O connector (CN13 pins 7[+] & 32[-]). The battery is necessary for preserving retained variables, absolute encoder offset, and real-time clock data.

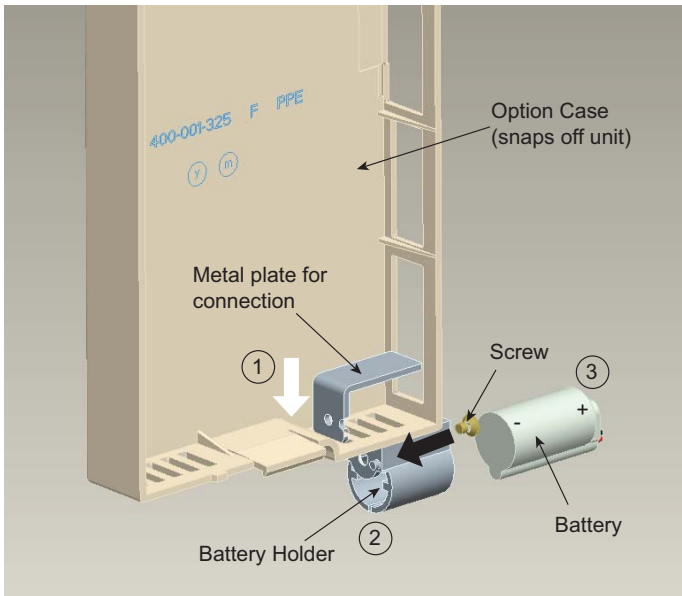

To initialize the non-volatile memory and clock settings after a battery is attached for the first time (or any time backup power has been lost), use the following procedure.

1. Power off the MP2600iec.
2. Set the "INIT" switch (S11) to ON.
3. Power on the MP2600iec and wait for the "RDY" LED to illuminate.
4. Power off the MP2600iec.
5. Set the "INIT" switch (S11) to OFF.

Battery Holder Installation Instructions:

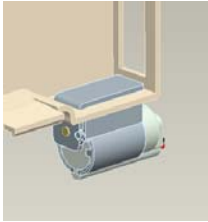

1. Remove the plastic case from the controller by pressing the tabs at the top and bottom.
2. Insert the tab of the metal plate into the last vent slot on the bottom front of the case as shown.
3. Line up the hole in battery holder with the hole in the metal plate and secure the battery holder with the screw provided.
4. Attach the extension cable to the battery and place the battery into the battery holder with the cable facing forward.
5. Attach the plastic case to the controller.
6. Plug the battery extension cable into the battery connector (CN14).

8 Ethernet

8.1 Connectivity Information

The MP2600iec supports 100MB speeds exclusively. Two separate networks are possible using both CN11A and CN11B. A default gateway can be specified only for the network attached to CN11A.

8.2 Ethernet Connector Details

Ethernet Connector Specification and Pin Array

The following table provides the Ethernet connector specifications.

| Connector Name | Number of Pins | Connector Model | | |
|----------------|----------------|-------------------|-----------------|-------------------|
| | | Module Side | Cable Side | Manufacturer |
| Ethernet | 8 | RJ-45 CAT5 Socket | RJ-45 CAT5 Plug | Pulse Engineering |

The following table provides Ethernet connector pin array / indicator light details.



| Pin Number | Signal Name | Description |
|------------|-------------|-------------------------|
| 1 | TXD+ | Transmitted data + side |
| 2 | TXD- | Transmitted data – side |
| 3 | RXD+ | Received data + side |
| 4 | – | – |
| 5 | – | – |
| 6 | RXD- | Received data – side |
| 7 | – | – |
| 8 | – | – |

8.3 Ethernet Cable

For the Ethernet cable, use a twisted pair cable with RJ-45 connector. Yaskawa strongly recommends the use of shielded ethernet cables. Ethernet ports are capable of auto-crossover, so crossover cables are not necessary.

8.4 Ethernet Connection Examples

Connection Example 1 (When using a repeater HUB)

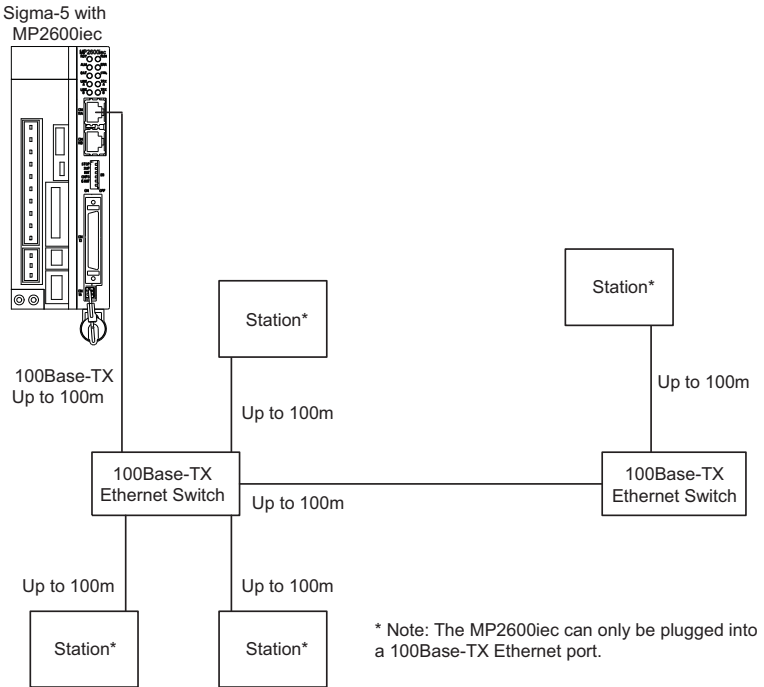

Specification

| Item | When Connecting to a Ethernet Switch |
|-------------------------------|--------------------------------------|
| Cable Length between Node-HUB | 100 m or less |
| Cable Length between HUBs | 100 m or less |
| Number of HUBs between Nodes | Unlimited |

Connection Example 2

Sigma-5 with MP2600iec

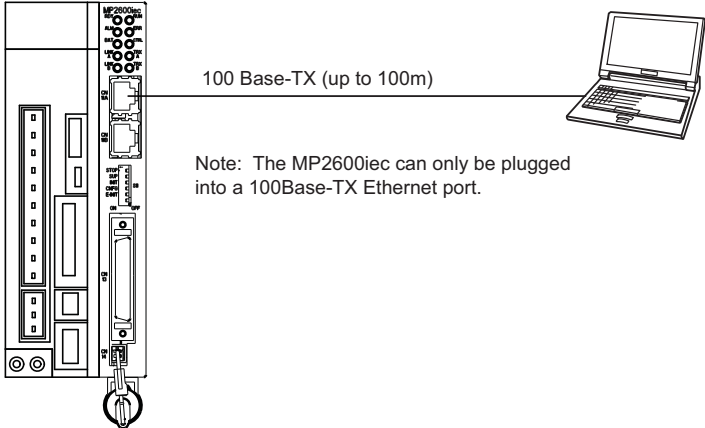

■ Caution

High frequency wave noise from other devices in the installation environment may cause errors in communications. When designing a system, use protective measures to avoid the influence of high frequency wave noise as follows:

1. Wiring

Wire Ethernet cables so that they are well-separated from other cable systems such as the main circuit or power lines.

2. Communication system (Ethernet)

- Communicate data to a remote device.
- Yaskawa strongly recommends shielded Ethernet cables.

3. Attach a ferrite core.

This will help reduce the occurrence of electrical interference.

Recommended ferrite core:

| Model | Manufacturer |
|-------------|------------------------------|
| E04SR301334 | Seiwa Electric Mfg. Co., Ltd |



Connection Example 3

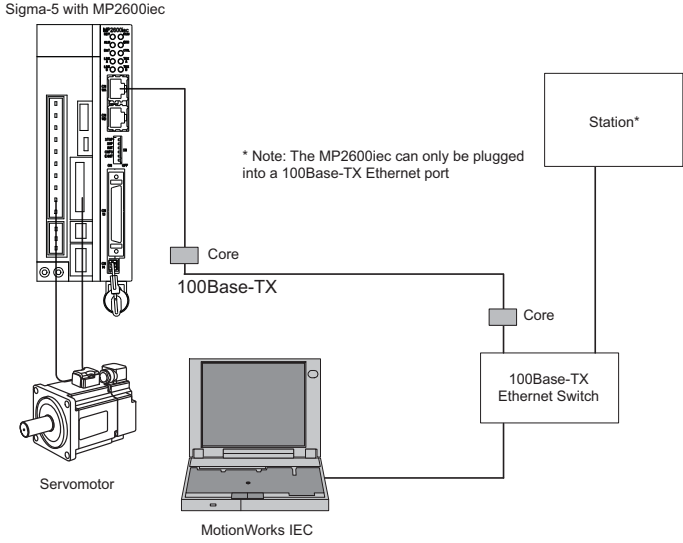

9 Cable Diagrams

9.1 CBK-U-MP2B-xx

Terminal Block - Controller

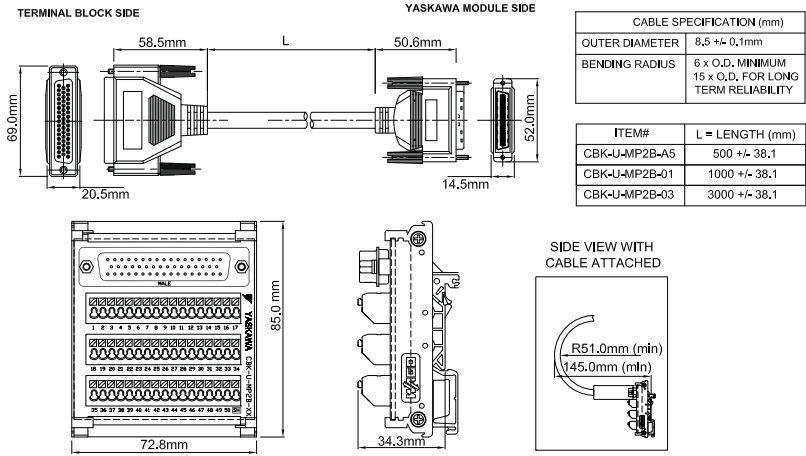

CBK-U-MP2B-XX Function Chart for MP2600iec

| Pin No. | Signal Name | I/O | Function | Pin No. | Signal Name | I/O | Function |
|---------|-------------|-----|-----------------------------------------|---------|-------------|-----|---------------------------------------------------------------------|
| 1 | AO | O | Analog output | 26 | AO_GND | O | Analog output ground |
| 2 | AI | I | Analog input | 27 | AI_GND | I | Analog input ground |
| 3 | - | - | - | 28 | reserved | - | - |
| 4 | PA+ | I | Phase A pulse (+) | 29 | PB+ | I | Phase B pulse (+) |
| 5 | PA- | I | Phase A pulse (-) | 30 | PB- | I | Phase B pulse (-) |
| 6 | GND | P | Encoder input ground | 31 | GND | P | Encoder input ground |
| 7 | BAT+ | P | Controller SRAM Battery (+) | 32 | BAT- | P | Controller SRAM Battery (-) |
| 8 | - | - | - | 33 | - | - | - |
| 9 | PILC5V | I | Phase-C latch pulse (-) for 5VDC input | 34 | PILC12V | I | Phase-C latch pulse (-) for 12VDC input |
| 10 | PILC24V | I | Phase-C latch pulse (-) for 24VDC input | 35 | PIL | I | Phase-C latch pulse (+) |
| 11 | DO_00- | O | Digital output 0 (-) | 36 | DO_01- | O | Digital output 1 (-) |
| 12 | DO_02- | O | Digital output 2 (-) | 37 | DO_03- | O | Digital output 3 (-) |
| 13 | DICOM | I | Digital input common | 38 | DICOM | I | Digital input common |
| 14 | DI_00 | I | Digital input 0 | 39 | DI_01 | I | Digital input 1 (shared with pulse latch input) |
| 15 | DI_02 | I | Digital input 2 | 40 | DI_03 | I | Digital input 3 |
| 16 | DI_04 | I | Digital input 4 | 41 | DI_05 | I | Digital input 5 |
| 17 | DI_06 | I | Digital input 6 | 42 | DI_07 | I | Digital input 7 |
| 18 | DO_04- | O | Digital output 4 (-) | 43 | DO_05- | O | Digital output 5 (-) |
| 19 | DO_06- | O | Digital output 6 (-) | 44 | DO_07- | O | Digital output 7 (-) |
| 20 | - | - | - | 45 | - | - | - |
| 21 | DO_00+ | O | Digital output 0 (+) | 46 | DO_01+ | O | Digital output 1 (+) |
| 22 | DO_02+ | O | Digital output 2 (+) | 47 | DO_03+ | O | Digital output 3 (+) |
| 23 | DO_04+ | O | Digital output 4 (+) | 48 | DO_05+ | O | Digital output 5 (+) |
| 24 | DO_06+ | O | Digital output 6 (+) | 49 | DO_07+ | O | Digital output 7 (+) (shared with position agreement 'COIN' signal) |
| 25 | - | - | - | 50 | - | - | - |

I = Input, O = Output, P = Power

9.2 CFC-U-MP2B-xx

Flying Lead - Controller

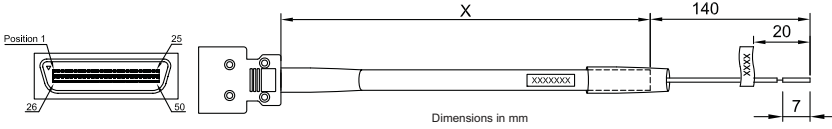

| Model | X = Cable Length |
|---------------|------------------|
| CFC-U-MP2B-A5 | 500 mm |
| CFC-U-MP2B-01 | 1000 mm |
| CFC-U-MP2B-03 | 3000 mm |

| CABLE SPECIFICATION (mm) | |
|--------------------------|---------|
| OUTER DIAMETER | 8,1 |
| BENDING RADIUS | 12 O.O. |

CFC-U-MP2B-xx I/O Pinout for MP2600ie

| Pin No. | Color (Solid/Band) | Signal Name | I/O | Function | Pin No. | Color (Solid/Band) | Signal Name | I/O | Function |
|---------|--------------------|-------------|-----|-----------------------------------------|---------|--------------------|-------------|-----|---------------------------------------------------------------------|
| 1 | BLK/RED | AO | O | Analog output | 26 | RED/BLK | AO_GND | O | Analog output ground |
| 2 | BLK/WHT | AI | I | Analog input | 27 | WHT/BLK | AI_GND | I | Analog input ground |
| 3 | RED/GRN | - | - | - | 28 | GRN/RED | - | - | - |
| 4 | BLK/BLU | PA+ | I | Phase A pulse (+) | 29 | BLK/BRN | PB+ | I | Phase B pulse (+) |
| 5 | BLU/BLK | PA- | I | Phase A pulse (-) | 30 | BRN/BLK | PB- | I | Phase B pulse (-) |
| 6 | RED/BLU | GND | P | Encoder input ground | 31 | BLU/RED | GND | P | Encoder input ground |
| 7 | RED/WHT | BAT+ | P | Controller SRAM Battery (+) | 32 | WHT/RED | BAT- | P | Controller SRAM Battery (-) |
| 8 | BLK/GRN | - | - | - | 33 | GRN/BLK | - | - | - |
| 9 | BLK/YEL | PILC5V | I | Phase-C latch pulse (-) for 5VDC input | 34 | ORG/BLK | PILC12V | I | Phase-C latch pulse (-) for 12VDC input |
| 10 | BLK/ORG | PILC24V | I | Phase-C latch pulse (-) for 24VDC input | 35 | YEL/BLK | PIL | I | Phase-C latch pulse (+) |
| 11 | RED/YEL | DO_00- | O | Digital output 0 (-) | 36 | WHT/ORG | DO_01- | O | Digital output 1 (-) |
| 12 | RED/BRN | DO_02- | O | Digital output 2 (-) | 37 | BLU/YEL | DO_03- | O | Digital output 3 (-) |
| 13 | RED/ORG | DICOM | I | Digital input common | 38 | ORG/RED | DICOM | I | Digital input common |
| 14 | GRN/WHT | DI_00 | I | Digital input 0 | 39 | WHT/GRN | DI_01 | I | Digital input 1 (shared with pulse latch input) |
| 15 | GRN/BLU | DI_02 | I | Digital input 2 | 40 | BLU/GRN | DI_03 | I | Digital input 3 |
| 16 | GRN/YEL | DI_04 | I | Digital input 4 | 41 | YEL/GRN | DI_05 | I | Digital input 5 |
| 17 | GRN/BRN | DI_06 | I | Digital input 6 | 42 | BRN/GRN | DI_07 | I | Digital input 7 |
| 18 | GRN/ORG | DO_04- | O | Digital output 4 (-) | 43 | BLU/BRN | DO_05- | O | Digital output 5 (-) |
| 19 | WHT/BLU | DO_06- | O | Digital output 6 (-) | 44 | BLU/ORG | DO_07- | O | Digital output 7 (-) |
| 20 | WHT/YEL | - | - | - | 45 | YEL/WHT | - | - | - |
| 21 | YEL/RED | DO_00+ | O | Digital output 0 (+) | 46 | ORG/WHT | DO_01+ | O | Digital output 1 (+) |
| 22 | BRN/RED | DO_02+ | O | Digital output 2 (+) | 47 | YEL/BLU | DO_03+ | O | Digital output 3 (+) |
| 23 | ORG/GRN | DO_04+ | O | Digital output 4 (+) | 48 | BRN/BLU | DO_05+ | O | Digital output 5 (+) |
| 24 | BLU/WHT | DO_06+ | O | Digital output 6 (+) | 49 | ORG/BLU | DO_07+ | O | Digital output 7 (+) (shared with position agreement 'COIN' signal) |
| 25 | WHT/BRN | - | - | - | 50 | BRN/WHT | - | - | - |

(I = Input, O = Output, P = Power)

9.3 SBK-U-VBA-xx

Terminal Block - Servo Amplifier.

YASKAWA MODULE SIDE

TERMINAL BLOCK SIDE

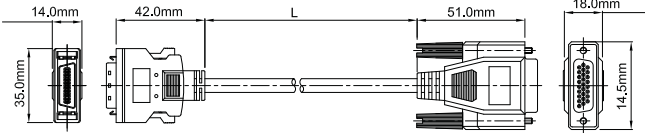

| CABLE SPECIFICATION (mm) | |
|--------------------------|---------------------------------------------------------|
| OUTER DIAMETER | 6.5 +/- 0.2mm |
| BENDING RADIUS | 6 x O.D. MINIMUM 15 x O.D. FOR LONG TERM RELIABILITY |

| ITEM# | L = LENGTH (mm) |
|--------------|-----------------|
| SBK-U-VBA-A5 | 500 +/- -38.1 |
| SBK-U-VBA-01 | 1000 +/- -38.1 |
| SBK-U-VBA-03 | 3000 +/- -38.1 |

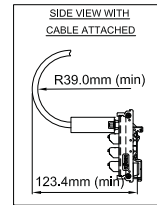
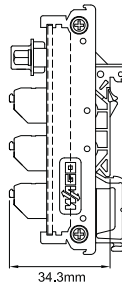
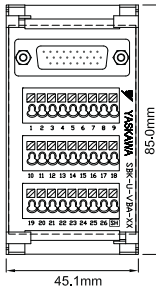

SBK-U-VBA-xx Function Chart for SGD V Servo Amplifier

| Pin No. | SGDV Mechatrolink-II type / SGD V Option type | |
|---------|-----------------------------------------------|-----------------------------------------------------------------------|
| | Signal | Function |
| 1 | /BK+ (/SO1+) | Brake interlock output (+) (General purpose output 1 (+)) |
| 2 | /BK- (/SO1-) | Brake interlock output (-) (General purpose output 1 (-)) |
| 3 | ALM+ | Servo alarm output (+) |
| 4 | ALM- | Servo alarm output (-) |
| 5 | - | |
| 6 | +24VIN | Control power supply for sequence signal input |
| 7 | P-OT (/SI1) | Forward run prohibited input (General purpose input 1) |
| 8 | N-OT (/SI2) | Reverse run prohibited input (General purpose input 2) |
| 9 | /DEC (/SI3) | Zero-point return deceleration switch input (General purpose input 3) |
| 10 | /EXT1 (/SI4) | External latch signal 1 input (General purpose input 4) |
| 11 | /EXT2 (/SI5) | External latch signal 2 input (General purpose input 5) |
| 12 | /EXT3 (/SI6) | External latch signal 3 input (General purpose input 6) |
| 13 | /SI0 | General purpose input 0 |
| 14 | BAT (+) | Battery (+) input |
| 15 | BAT (-) | Battery (-) input |
| 16 | SG | Signal ground |
| 17 | PAO | Phase-A pulse output (+) |
| 18 | /PAO | Phase-A pulse output (-) |
| 19 | PBO | Phase-B pulse output (+) |
| 20 | /PBO | Phase-B pulse output (-) |
| 21 | PCO | Phase-C pulse output (+) |
| 22 | /PCO | Phase-C pulse output (-) |
| 23 | /SO2+ | General purpose output 2 (+) |
| 24 | /SO2- | General purpose output 2 (-) |
| 25 | /SO3+ | General purpose output 3 (+) |
| 26 | /SO3- | General purpose output 3 (-) |

Note: General purpose input and output signals are shown with their default signals assigned - signal assignment may have been changed by parameter

9.4 JZSP-CSI02-x-E

Flying Lead - Servo Amplifier

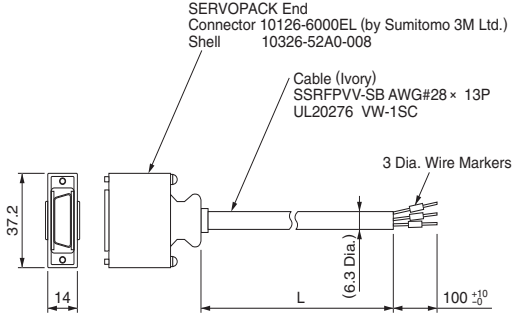

Dimensions in mm

| Model | Cable Length |
|----------------|--------------|
| JZSP-CSI02-1-E | 1000 mm |
| JZSP-CSI02-2-E | 2000 mm |
| JZSP-CSI02-3-E | 3000 mm |

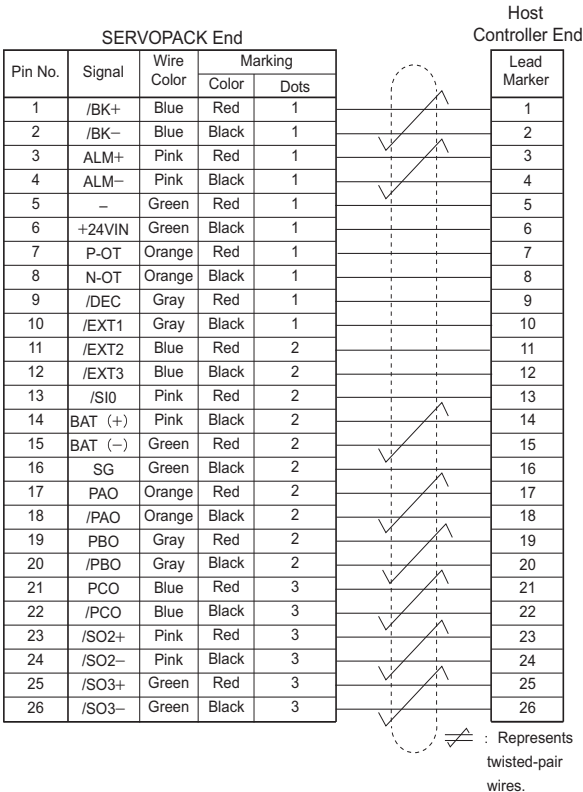

10 Firmware Upgrade

It is possible to upgrade the Controller firmware in the field.

For detailed instructions, please refer to Product Note PN.MCD.08.083: Upgrading the MP2□□□iec Controller Firmware. This document may be downloaded from our website, www.yaskawa.com.

This page left intentionally blank

11 EMC Installation Conditions

This section describes the recommended installation conditions that satisfy EMC guidelines for each model of the SGD V SERVOPACK. The conditions required for the standard type (base-mounted) of the SERVOPACK are described. Refer to this section for other SERVOPACK models such as the rack-mounted types as well.

This section describes the EMC installation conditions satisfied in test conditions prepared by Yaskawa. The actual EMC level may differ depending on the actual system's configuration, wiring, and other conditions. However, because this product is built-in, check that the following conditions are still met after being installed in the user's product.

The applicable standards are EN55011/A2 group 1 class A, EN61800-3, and EN61000-6-2.

Ethernet Communication Cables: Use a category 5 or higher cable with double, aluminum tape and braided shielding according to the standard EN50288-2-2.

Single-phase 100 V

SGDV-□□□FE1A (□□□ = R70, R90, 2R1, 2R8) + SGDV-OCC02A

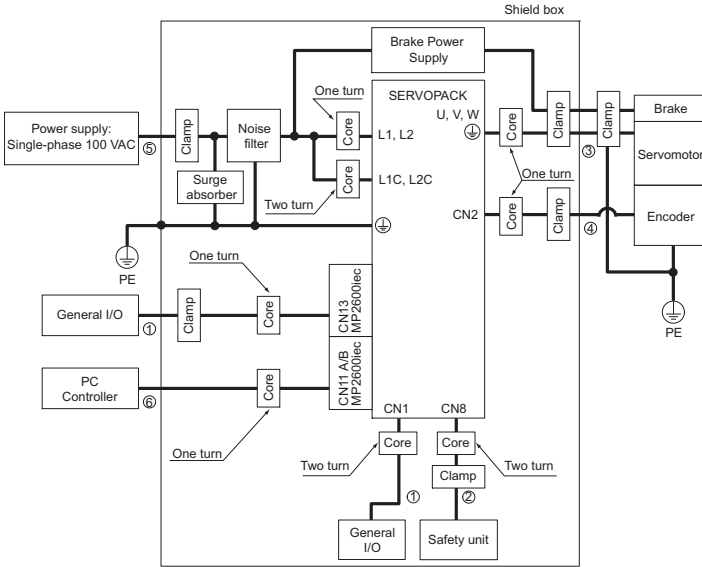

| Symbol | Cable Name | Specification |
|--------|------------------------------|---------------|
| ① | I/O signal cable | Shield cable |
| ② | Safety signal cable | Shield cable |
| ③ | Motor main circuit cable | Shield cable |
| ④ | Encoder cable | Shield cable |
| ⑤ | Main circuit cable | Shield cable |
| ⑥ | Ethernet communication cable | Shield cable |

Three-phase 200 V

SGDV-□□□AE1A (□□□ = R70, R90, 1R6, 2R8, 3R8, 5R5, 7R6) +
SGDV-OCC02A

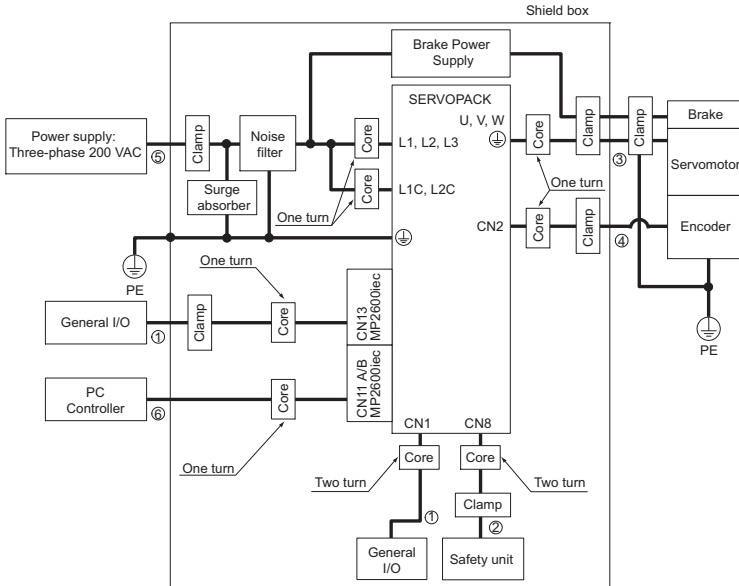

| Symbol | Cable Name | Specification |
|--------|------------------------------|---------------|
| ① | I/O signal cable | Shield cable |
| ② | Safety signal cable | Shield cable |
| ③ | Motor main circuit cable | Shield cable |
| ④ | Encoder cable | Shield cable |
| ⑤ | Main circuit cable | Shield cable |
| ⑥ | Ethernet communication cable | Shield cable |

Three-phase 200 V
 SGDV-□□□AE1A (□□□ = 120) + SGDV-OCC02A

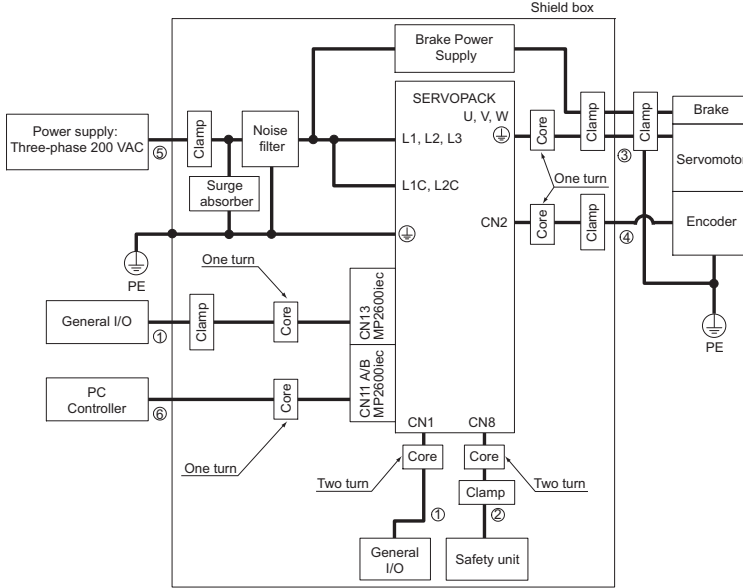

| Symbol | Cable Name | Specification |
|--------|------------------------------|---------------|
| ① | I/O signal cable | Shield cable |
| ② | Safety signal cable | Shield cable |
| ③ | Motor main circuit cable | Shield cable |
| ④ | Encoder cable | Shield cable |
| ⑤ | Main circuit cable | Shield cable |
| ⑥ | Ethernet communication cable | Shield cable |

Three-phase 200 V SGDV-□□□AE1A (□□□ = 180, 200, 330) + SGDV-OCC02A

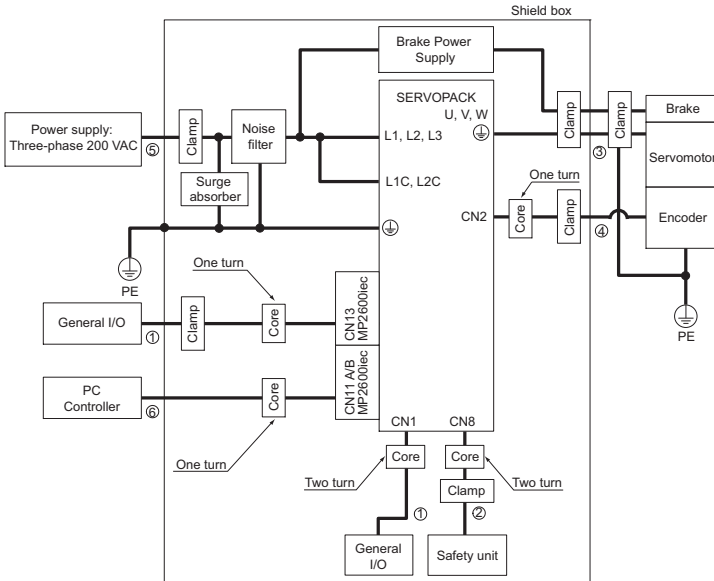

| Symbol | Cable Name | Specification |
|--------|------------------------------|---------------|
| ① | I/O signal cable | Shield cable |
| ② | Safety signal cable | Shield cable |
| ③ | Motor main circuit cable | Shield cable |
| ④ | Encoder cable | Shield cable |
| ⑤ | Main circuit cable | Shield cable |
| ⑥ | Ethernet communication cable | Shield cable |

Three-phase 200 V
 SGDV-□□□AE1A (□□□ = 470, 550, 590, 780) + SGDV-OCC02A

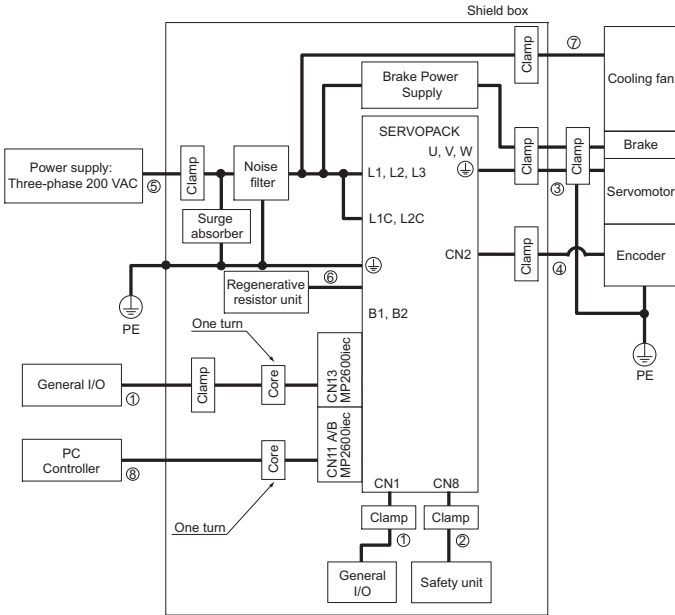

| Symbol | Cable Name | Specification |
|--------|----------------------------------|------------------|
| ① | I/O signal cable | Shield cable |
| ② | Safety signal cable | Shield cable |
| ③ | Motor main circuit cable | Shield cable |
| ④ | Encoder cable | Shield cable |
| ⑤ | Main circuit cable | Shield cable |
| ⑥ | Regenerative resistor unit cable | Non-shield cable |
| ⑦ | Cooling fan cable | Shield cable |
| ⑧ | Ethernet communication cable | Shield cable |

Three-phase 400 V

SGDV-□□□□DE1A (□□□ = 1R9, 3R5, 5R4, 8R4, 120, 170)

+ SGDV-OCC02A

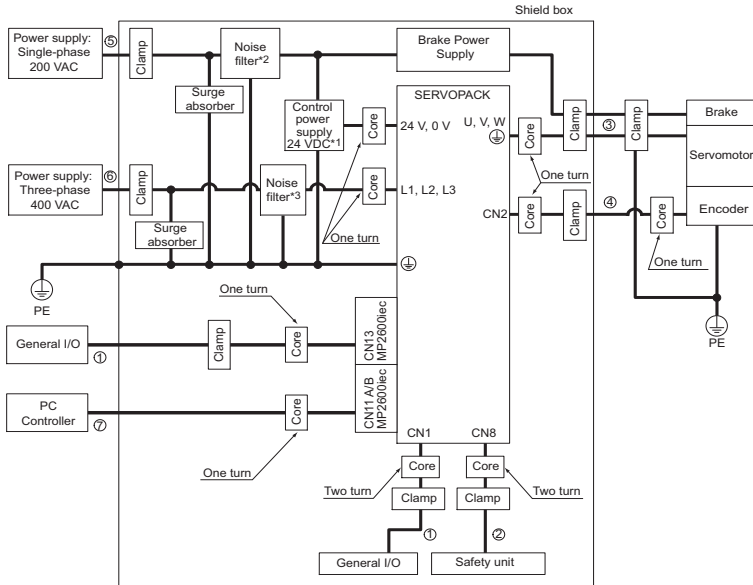

| Symbol | Cable Name | Specification |
|--------|------------------------------|---------------|
| ① | I/O signal cable | Shield cable |
| ② | Safety signal cable | Shield cable |
| ③ | Motor main circuit cable | Shield cable |
| ④ | Encoder cable | Shield cable |
| ⑤ | Control power cable | Shield cable |
| ⑥ | Main circuit cable | Shield cable |
| ⑦ | Ethernet communication cable | Shield cable |

- * 1. Products that have received CE marking are recommended for the 24 VDC power supply.
- * 2. Install the following noise filter on the power line between the single-phase 200 V power supply and the 24 VDC power supply.
Model number: FN2070-6/07 (SCHAFFNER).
- * 3. For more information on this filter, refer to Sigma-5 Product Catalog (YEA-KAEPS80000042).

Three-phase 400 V

SGDV-□□□□DE1A (□□□ = 210, 260, 280, 370) + SGDV-OCC02A

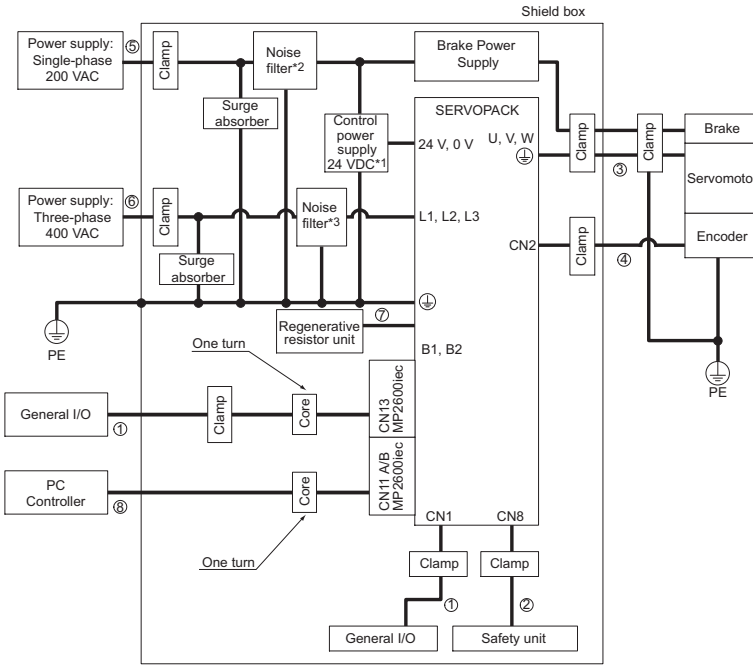

| Symbol | Cable Name | Specification |
|--------|----------------------------------|------------------|
| ① | I/O signal cable | Shield cable |
| ② | Safety signal cable | Shield cable |
| ③ | Motor main circuit cable | Shield cable |
| ④ | Encoder cable | Shield cable |
| ⑤ | Control power cable | Shield cable |
| ⑥ | Main circuit cable | Shield cable |
| ⑦ | Regenerative resistor unit cable | Non-shield cable |
| ⑧ | Ethernet communication cable | Shield cable |

- * 1. Products that have received CE marking are recommended for the 24 VDC power supply.
- * 2. Install the following noise filter on the power line between the single-phase 200 V power supply and the 24 VDC power supply.
Model number: FN2070-6/07 (SCHAFFNER).
- * 3. For more information on this filter, refer to Sigma-5 Product Catalog (YEA-KAEPS80000042).

Attachment Methods of Ferrite Cores

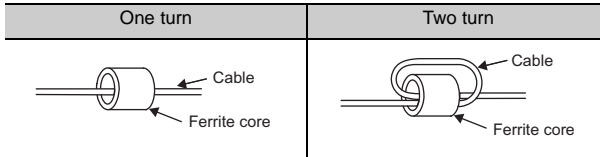

Recommended Ferrite Core

| Cable Name | Ferrite Core Model | Manufacturer |
|--------------------------|--------------------|-----------------|
| Motor main circuit cable | ESD-SR-250 | NEC TOKIN Corp. |

Recommended Noise Filter and Surge Absorber

For more information on recommended noise filters and surge absorbers, refer to Sigma-5 Product Catalog. (YEA-KAEPS800000 42)

Fixing the Cable

Fix and ground the cable shield using a piece of conductive metal.

- Example of Cable Clamp

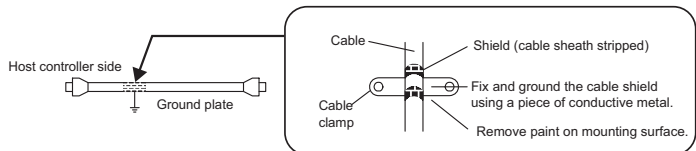

Shield Box

A shield box, which is a closed metallic enclosure, is effective as reinforced shielding against electromagnetic interference (EMI) from SERVOPACKs. The structure of the box should allow the main body, door, and cooling unit to be attached to the ground. The box opening should be as small as possible.

Note: Do not connect the digital operator and the analog monitor cable to the SERVOPACK during operations. Connect them only when the machinery is stopped during maintenance.



IRUMA BUSINESS CENTER (SOLUTION CENTER)

480, Kamifujisawa, Iruma, Saitama, 358-8555, Japan
Phone: 81-4-2962-5696 Fax: 81-4-2962-6138

YASKAWA ELECTRIC CORPORATION

New Pier Takeshiba South Tower, 1-16-1, Kaigan, Minatoku, Tokyo, 105-6891, Japan
Phone: 81-3-5402-4511 Fax: 81-3-5402-4580
<http://www.yaskawa.co.jp>

YASKAWA AMERICA, INC.

2121 Norman Drive South, Waukegan, IL 60085, U.S.A.
Phone: (800) YASKAWA (800-927-5292) or 1-847-887-7000 Fax: 1-847-887-7370
<http://www.yaskawa.com>

YASKAWA ELÉTRICO DO BRASIL COMÉRCIO LTDA.

Avenda Fagundes Filho, 620 Bairro Saude, São Paulo, SP04304-000, Brasil
Phone: 55-11-3585-1100 Fax: 55-11-5581-8795
<http://www.yaskawa.com.br>

YASKAWA ELECTRIC EUROPE GmbH

Hauptstraße 185, 65760 Eschborn, Germany
Phone: 49-6196-569-300 Fax: 49-6196-569-398

YASKAWA ELECTRIC UK LTD.

1 Hunt Hill Orchardton Woods, Cumbernauld, G68 9LF, United Kingdom
Phone: 44-1236-735000 Fax: 44-1236-458182

YASKAWA ELECTRIC KOREA CORPORATION

7F, Doore Bldg. 24, Yeoido-dong, Youngdungpo-Ku, Seoul, 150-877, Korea
Phone: 82-2-784-7844 Fax: 82-2-784-8495

YASKAWA ELECTRIC (SINGAPORE) PTE. LTD.

151 Lorong Chuan, #04-01, New Tech Park, 556741, Singapore
Phone: 65-6282-3003 Fax: 65-6289-3003

YASKAWA ELECTRIC (SHANGHAI) CO., LTD.

No. 18 Xizang Zhong Road, Room 1702-1707, Harbour Ring Plaza, Shanghai, 200001, China
Phone: 86-21-5385-2200 Fax: 86-21-5385-3299

YASKAWA ELECTRIC (SHANGHAI) CO., LTD. BEIJING OFFICE

Room 1011A, Tower W3 Oriental Plaza, No. 1 East Chang An Ave.,
Dong Cheng District, Beijing, 100738, China
Phone: 86-10-8518-4086 Fax: 86-10-8518-4082

YASKAWA ELECTRIC TAIWAN CORPORATION

9F, 16, Nanking E. Rd., Sec. 3, Taipei, Taiwan
Phone: 886-2-2502-5003 Fax: 886-2-2505-1280