

Confident. Consistent. Capable. 

MOTION CONTROL PRODUCTS



IT'S PERSONAL
YASKAWA

YASKAWA

Be Capable of More.

If you're a machine builder or equipment user, you know all about high expectations, limited resources and tight deadlines. Your success depends on suppliers who respond with precisely the right products, delivered with consistency and reliability that never fails.

Yaskawa has been putting this brand of customer success in motion for 100 years. It shows in today's commitment to innovative automation technology, to engineering expertise, and to the operational strength that is the proof behind our promise.



CONFIDENT

Products That Perform.

Product performance is more than just a specification. It is the confidence that your machines will work as expected ... every time ... in a way that consistently outperforms your competition.

Breakthrough Performance. Your machine functions at a level that can't be achieved with other automation solutions.

A Competitive Price. You can provide an effective, trustworthy solution at a cost that makes your machine an exceptional value.

Quality, Right Out of the Box. Your systems work as expected, the first time and every time.



CONSISTENT

Excellence in Operation.

Problems with component quality, supply chain hiccups and downtime surprises are simply unacceptable. You need a partner with the operational rigor and expertise to engineer them out of existence.

Inventory for Faster Fulfillment.

Your products are available precisely when and where you need them.

Legendary Quality. Your equipment continues to operate reliably and without intervention.

Global Service and Support. You can rely on timely, helpful technical assistance wherever you or your equipment may be.



CAPABLE

Engineering Expertise. Right Now.

Focus your engineers on their core competencies while still delivering effective machine automation, thanks to a team of Yaskawa engineers who can instantly add power to automation design, development and support.

Motion Application Expertise. Call on proven automation experts to assist with electromechanical design and development.

Software Development. Turn to a team of automation software specialists to streamline your development process.

Engineered Systems. Implement complete mechanical and electrical sub-systems that are fully supported for the life of your machine.



“It’s Personal” is our commitment to giving you a great experience each time you deal with Yaskawa.

We train people, create products and treat customers with the belief that everything we do matters. With an attitude like this, it’s only natural to see everything we do as an intensely personal act.

We commit to that at Yaskawa. We make it happen.

Because to us ... it’s personal.

PRODUCTS THAT PERFORM

Power Up Your Productivity

When More is Not Enough.

In a rapidly changing global marketplace, today's landmarks for world-class machine performance are tomorrow's everyday expectations. Your customers demand the maximum in machine effectiveness, throughput and quality, regardless of a machine's mechanical and design limitations. Your job is to do it all, and at a competitive cost.

Your Need: Performance Plus.

To stay ahead of competition, you need to continually push the edge of the envelope on machine performance. This extraordinary effort consumes your time, stresses machine mechanisms and impacts the reliability of your finished product. The result is a risk of lost revenue, or of disappointing your key customers.

This environment leaves no room for components that can't be trusted, or for suppliers that create delays in development and delivery.

What If...

- You could significantly reduce, or completely eliminate, the time spent optimizing the motion performance of your machine?
- Your servo system could overcome the mechanical limitations of your design?
- You could confidently achieve the highest attainable levels of throughput and effectiveness?



BE CONFIDENT

**Product performance
is more than just a
specification.**



Your Gain: A Boost in Productivity

With motion control systems from Yaskawa, you have access to solutions that provide real impact on equipment effectiveness. You enjoy confidence that your machines will work as expected every time, which gives you an advantage over your competitors.

Tuning Time Savings.

Yaskawa's well-earned reputation for the best performance in the industry is enhanced by our Tuning-less Mode, that keeps your machine running at peak efficiency for life by eliminating the need to optimize tuning gains. Electronic Vibration Suppression automatically compensates for limitations in a machine's mechanical design, creating consistent performance in a machine's output.

Initial Quality.

The definition of initial quality is simple: you get what you expect. Yaskawa products ship on time, work out of the box every time, perform as expected, and continue to do so for the life of your machine.

Competitive Price.

Yaskawa maintains a #1 market share in some of the world's most price-sensitive industries, which is proof of Yaskawa's superior balance between operational performance and return on your investment.



EXCELLENCE IN OPERATION

Resources, Responsiveness and Reliability.

Today, Quality is Only the Beginning.

Your global customer base means your machines must operate anywhere in the world. Your customers' cultures may be different, but they share one thing in common: the need for instant gratification when it comes to product availability, flawless product performance and immediate 24/7 service and support.

Your Need: Speed and Success.

When your customers are demanding instant perfection, you can't afford to work with ordinary suppliers. Everyone in your supply chain must be completely reliable in supply and rapid in response to any customer question.

Quality problems simply cannot be part of the equation. Nor can a shortage in engineering support in a fast-tracked machine design process.

What If...

- You had no worries about the reliability of your automation system?
- You could reduce your machine lead time and spare parts inventory?
- You had expert service and support wherever your machines might be located?

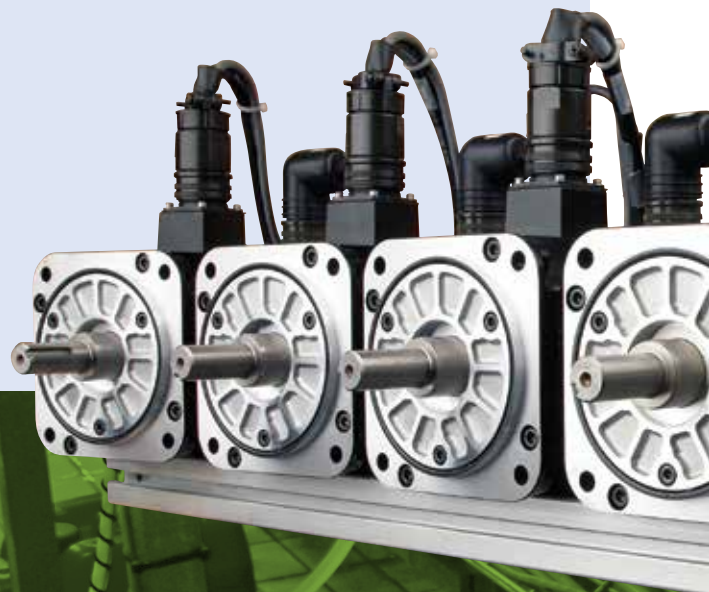

BE CONSISTENT

Yaskawa quality is the industry benchmark.

From 2011 to 2013, Yaskawa shipped nearly 150,000 Sigma-5 motors in North America with only 10 warranty failures.



Your Gain: Global Excellence

Yaskawa has a long track record for reliable quality, responsive support and rapid product availability. The reason behind these achievements is a simple one: our customers can't afford to settle for anything less.

Inventory for Faster Fulfillment.

Yaskawa maintains a \$14M inventory of motion products in the US, for 95%+ on-time response to customer requests

A Legacy of Quality.

Yaskawa's award-winning quality has been the motion industry's quality benchmark for decades. Yaskawa products practically never fail, and we can stand behind this statement with 100 years of evidence.

Global Service and Support.

As a truly global company, Yaskawa can offer local service and support worldwide. Whether your machine is installed in Asia, Europe or the Americas, Yaskawa can help reduce service costs by providing expert service anywhere you need it.

IT'S PERSONAL
YASKAWA

ENGINEERING EXPERTISE, NOW.

Insight and Innovation. Instantly.

Top Resources for Tough Problems.

Today's companies face an acute talent shortage. At the same time, the demand for innovative solutions and effective technologies is stronger than ever. New designs must be brought to market in months or weeks instead of years, all while increasing efficiency, flexibility and quality.

Few companies can afford the luxury of a large engineering staff. True automation expertise is increasingly rare, and the competition for hiring automation engineers is stiff.

Engineers, or Firefighters?

Your engineering staff needs to focus on your company's core competencies. Instead, they are distracted with putting out fires when they should be creating innovations.

These limitations slow the development of automation solutions. They also lead to unreliable long-term operation of your machine. Trial and error in the development process is no longer an option. Nor is downtime or lost production.

What if...

- You could add expert automation engineers to your staff at the exact moment you need them?
- Responsibility for designing and supporting your automation could be handed off to someone you trusted?
- Your engineering staff was free to focus on areas where they can truly add value?



BE CAPABLE OF MORE

You no longer have the luxury of a large engineering staff.



Your Gain: Effective Innovation

For the past 100 years of industrial history, Yaskawa engineers have worked side-by-side with machine builders and end users in manufacturing. Then as now, we've functioned as an extension of your engineering staff to create elegant, reliable automation.

The Yaskawa commitment begins by listening, fully understanding your application and process, the results you need to achieve, your time frame and cost structure. This effort to understand your design and process is unique. It's what sets us apart, and it results in a set of tangible benefits that go directly to your engineering bottom line.

Motion Application Expertise.

Yaskawa's engineering expertise can be applied to any stage of machine development.

- System concept design
- Component selection
- Electrical design
- Mechatronic design
- Machine start-up
- Programming
- Optimization
- Troubleshooting

Software Development.

Software design and development can be the key to an automated machine's success or the reason for its failure. Yaskawa software expertise makes the difference, thanks to a staff of engineers who understand proper software design and the ways it can impact real-world machine operation.

Engineered Systems.

Under the banner of Engineered Systems, Yaskawa offers a range of advanced products and services. They include complete machine retrofits, enclosure design and manufacturing, electromechanical assembly design, and integration of Yaskawa servo technology into a "purpose built" mechanism for your application.

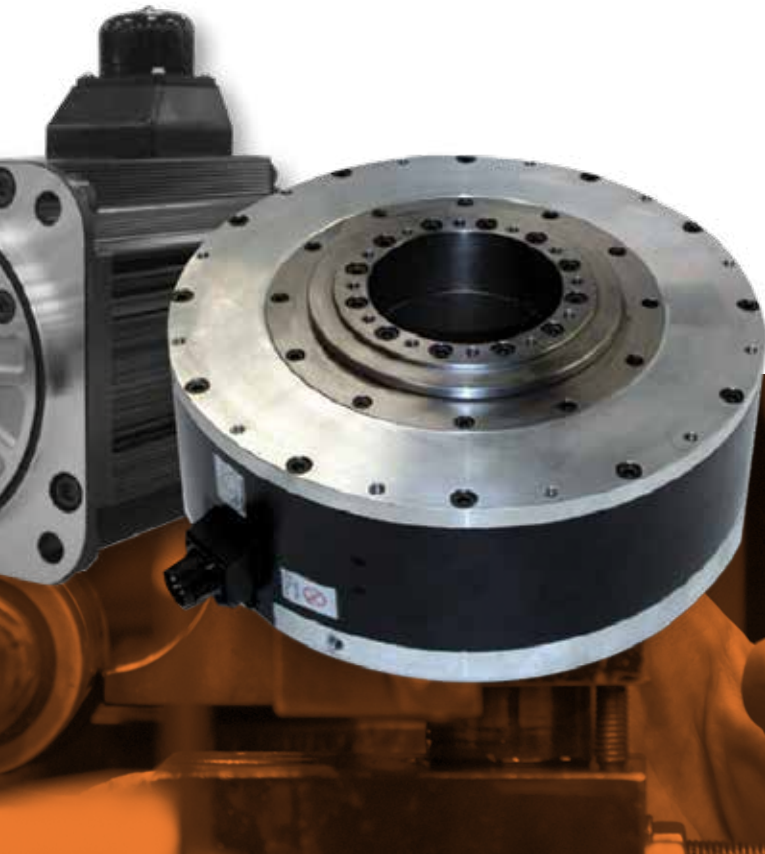

Global Overview

Yaskawa - Global Leader in Automation, Drive Technology, and Robotics.

Yaskawa is one of the world's leading manufacturers of drive technology, industrial automation, and robotics. Founded in 1915, Yaskawa has been a pioneer in the drive to optimize the productivity and efficiency of machines and industrial systems.

- \$3.6B/year in global sales
- 800,000 servo amplifiers per year
- 900,000 servo motors per year
- 1.8 million inverters per year
- 20,000 robots per year
- Over 14,000 associates worldwide
- Yaskawa Sales, Service, and Manufacturing companies in 25 countries

Yaskawa Global Locations.

North America & South America

U.S.A.
Brazil
Canada
Mexico

Asia Pacific

China
Japan
Korea
Taiwan
Singapore
Thailand
Indonesia
India

Africa

South Africa

Europe

Germany
Sweden
U.K.
Israel
Italy
France
Spain
Finland
Netherlands
Slovenia
Czech Republic
Turkey



IT'S PERSONAL
YASKAWA

Over the past 30 years,
Yaskawa has produced more than
10 million servo amplifiers, 18 million variable
frequency drives, and 300,000 robots.

Product Portfolio: Total System Solutions.

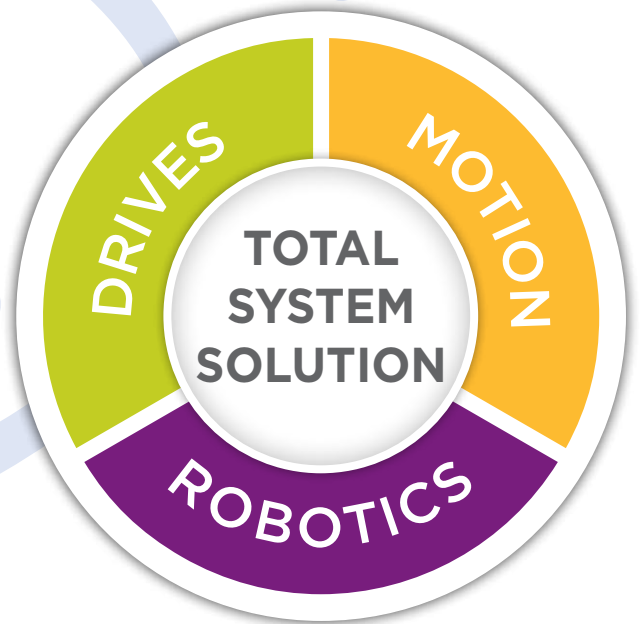

SOFTWARE

Software

MotionWorks® IEC, Yaskawa's IEC61131-3 programming environment, gives a programmer the best of several programming languages in one development platform.



CONTROL

Machine Controllers

MPiec Machine Controllers integrate Yaskawa's powerful motion engine with the IEC61131-3 and PLCopen programming standards, for control from 1 to 62 axes.



INPUT OUTPUT

I/O

Yaskawa's VIPA SLIO is one of the most effective and modern decentralized I/O systems available, providing exceptional usability in an extremely compact and functional design.



SERVO AMPLIFIERS & MOTORS

Servo Amplifiers and Motors

Rotary, Linear, and Direct Drive servos from 3W to 55kW offer advanced features, including Tuning-less Mode and Electronic Vibration Suppression.



INVERTER DRIVES

Inverter Drives

Yaskawa drives incorporate the latest technological advancements in variable speed AC motor control, with power ranges from fractional HP to 2250 HP.



ROBOTICS

Robotics

The Yaskawa Robotic product portfolio ranges from 4-15 axis industrial robots with load capacities of 2 to 800 kg to special machines, devices, and turnkey systems.



MPi^{ec} MACHINE CONTROLLERS



Easy for You. Consistent for Everyone.

To stay a step ahead of the competition, you need programming software that is easy to learn, familiar in format and efficient to work with.

Your controller hardware must be readily accessible to peripheral devices anywhere in the world, yet keep functional control and user experience perfectly consistent from machine to machine.

The Demand: Flexible and Reliable.

Today's customers need to keep a finger on the pulse of their machines at all times. Success means maintaining peak productivity, total reliability and endless freedom to interact with the systems they control.

What if ...

- Key elements of code are already written for you, using a standard, globally recognized programming language?
- Your customers can safely access your machine controller from anywhere in the world?
- Programming one of your machines easily leads to programming all your machines?

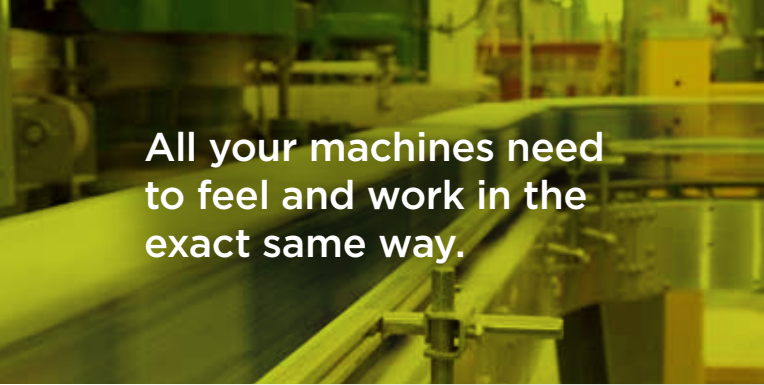

All your machines need to feel and work in the exact same way.

Yaskawa Control: What You Gain

With easy-to-learn MotionWorks® IEC software and MPiec hardware, your engineers start programming faster and stay connected more easily.

The result? Faster machine commissioning and more rapid machine delivery to market.

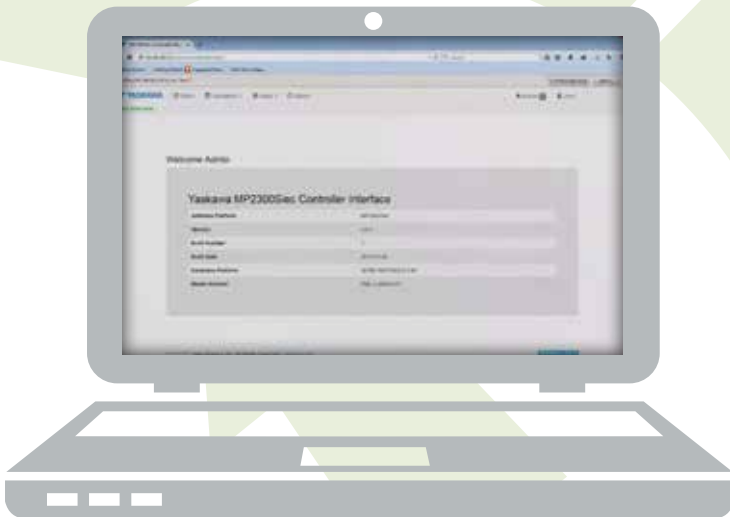

A Familiar Programming Standard

MotionWorks IEC complies with IEC 61131-3, and provides five globally recognized standard programming languages. It includes motion function blocks that adhere to the PLCopen standard. Experienced control engineers will find this software comfortably familiar, and learning to program with MotionWorks IEC has never been easier.

Built-in Yaskawa Toolboxes

Yaskawa toolboxes make programming common functions so easy, it's like having a Yaskawa engineer working by your side. Development time is reduced because standard code elements are already written and ready for use.

A Reusable Code Library

Import and re-use previously developed logic to speed up new projects. Re-use your own work or draw on logic created by others.

Easy Connectivity, Worldwide

An MPiec controller is your gateway to full control of a machine at any remote location with internet access. Keep a constant finger on the pulse of machine operation, from your own factory floor or anywhere worldwide.

Web Server Updates

MPiec controllers allow loading of programs and updating of firmware from any web browser, with no other software required. Browser-based controller status data helps reduce maintenance time and cost.

Scalability

All our single-axis to multi-axis MPiec controllers utilize the same MotionWorks IEC software platform, making programming and maintenance consistent for all machine sizes.

Three Networks to Choose From

MPiec controllers include the MECHATROLINK motion network, plus Modbus TCP and EtherNet/IP communication networks at no extra cost. This ensures an economical way of connecting to all the devices in your machine.

SYSTEM CONFIGURATION

MPiec Controller



HMI



Modbus TCP

Ethernet



VIPA SLIO I/O

MECHATROLINK



Sigma-5 SERVOPACKS



Rotary Motors

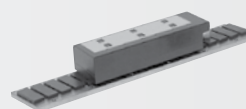

Linear Motors

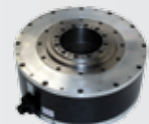

Direct Drive Motors

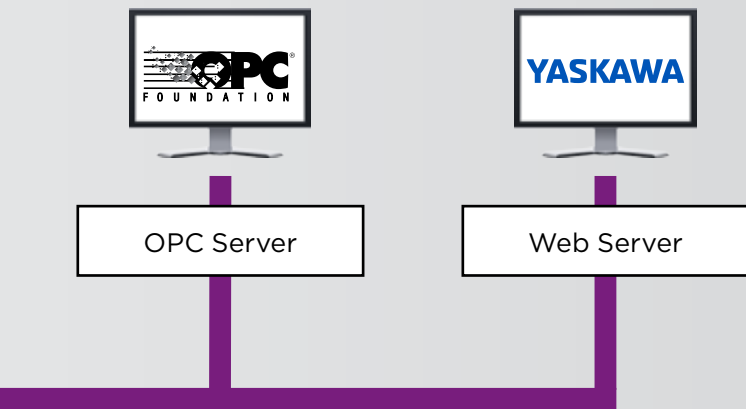

A controller that gets you to the position you want, when you want it:

- Deterministic high speed MECHATROLINK network
- MECHATROLINK retry function
- Dedicated CPU for your motion needs
- High CPU scan rate

Program all of your controllers the same way every time:

- Standard IEC 61131-3 programming languages
- Reusable PLCopen function blocks
- Reusable standard Yaskawa toolboxes
- Decades of high quality motion experience

Your entire machine at your fingertips with Yaskawa controllers:

- Sigma-5 servos via MECHATROLINK
- Built in web server
- OPC server
- EtherNet/IP
- Modbus TCP
- Wide range of HMIs and I/Os



MPiec Machine Controllers

SOFTWARE



- Number of Tasks: 1
- Number of Resources: 1
- IEC 61131-3 Languages: Ladder Diagram, Function Block, Structure Text
- POU Grouping: No
- Configurable Task Priority: No
- Configurable I/O Task Assignment: No
- Auto Save Setting: No
- Debug PowerFlow: No
- Password Protection: No
- Project Comparison: No



- Number of Tasks: 16
- Number of Resources: 1
- IEC 61131-3 Languages: Ladder Diagram, Function Block, Structure Text, Sequential Function Chart, Instruction List
- POU Grouping: Yes
- Configurable Task Priority: Yes
- Configurable I/O Task Assignment: Yes
- Auto Save Setting: Yes
- Debug PowerFlow: Yes
- Password Protection: Yes
- Project Comparison: Yes

Reusable Code and Yaskawa Application-specific Toolboxes

Drawing on decades of motion experience, Yaskawa created toolboxes with pre-developed code for specific applications. Leverage Yaskawa expertise to minimize programming time and effort. Libraries also enable importing and re-use of logic you've previously developed, saving even more time on subsequent projects.

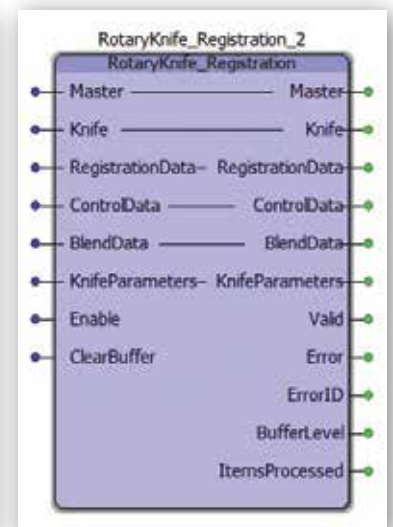
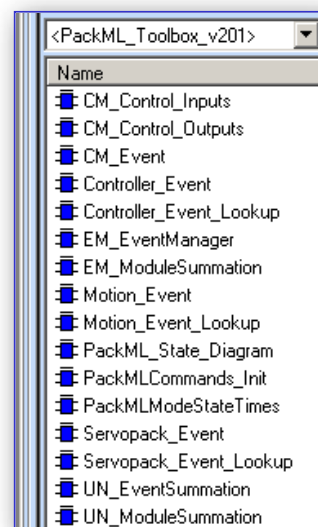

Sequential Function Chart

Sequential Function Chart (SFC) is one of the standardized languages available in IEC 61131-3 and is supported in the Professional version of MotionWorks® IEC.

SFC allows the programmer to graphically represent program elements, for easier organization of steps, actions and transitions. Active steps are indicated in red to simplify troubleshooting of complex operations.

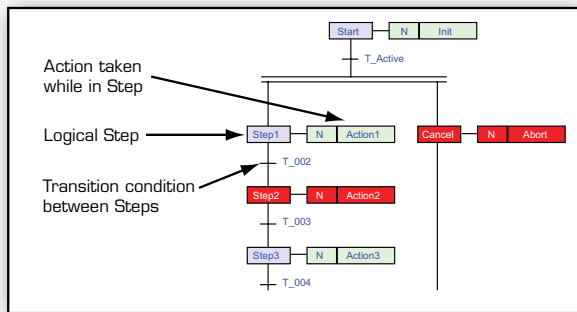

Standard Programming Environment

MotionWorks IEC software complies to the IEC 61131-3 standard. It also has motion function blocks that adhere to the PLCopen standard, which is your assurance that programs will be developed and executed with predictable behavior.



Cam Editor

Let Yaskawa handle the hard work of camming applications with a Cam Editor built into MotionWorks IEC Pro. Create, edit, export and import Cam profiles, or convert cam tables back and forth from Structured Text code for programming use.

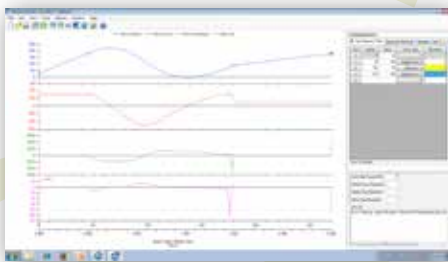

Camming Function Blocks

Electronic camming controls the positional relationship of a pair of axes based on a master/slave lookup table.

MotionWorks IEC includes 10 function blocks dedicated to camming. Yaskawa creates customizations based on the PLCopen specification, previous controller cam technology, and decades of synchronized motion experience. The function blocks fall into one of four functional topics:

Cam Data Management

- CamFileSelect
- CamStructSelect
- ReleaseCam

Cam Engagement

- CamIn
- CamOut

On-the-Fly Adjustments

- CamShift
- CamScale
- SlaveOffset

Cam Data Transfer

- ReadCamTable
- WriteCamTable

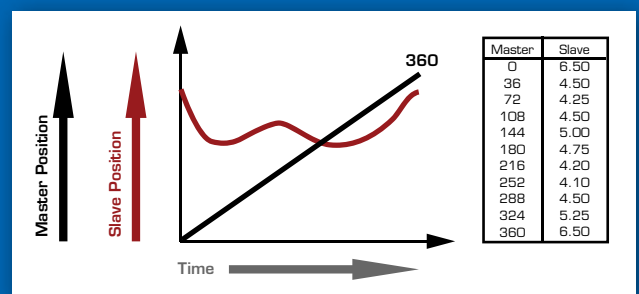
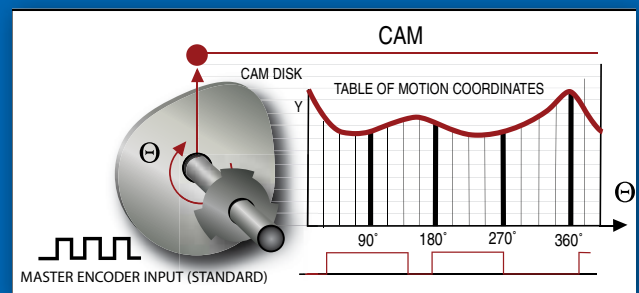

CONTROLLER HARDWARE

You need powerful processing to meet today's needs and prepare for tomorrow's innovations. At the same time, your machine control must offer outstanding ease of use and an extensive track record of automation success. MPiec machine control offers both, plus extra features that add industry-leading user flexibility.

All MPiec Machine Controllers are equipped with the MECHATROLINK motion network. MECHATROLINK combines the speed of modern motion networks with unmatched noise immunity and robust performance. The within-cycle RETRY function of MECHATROLINK responds to a communication error by automatically resending the packet within the same cycle. This creates far fewer gaps in the the flow of data, even in extremely high noise environments.

Without the RETRY function, all data for all slaves are eliminated and slaves must wait for the next cycle. The master must retransmit at a higher rate to compensate for dropped information. The result can be poor quality in machined parts, as shown in the test data at left.

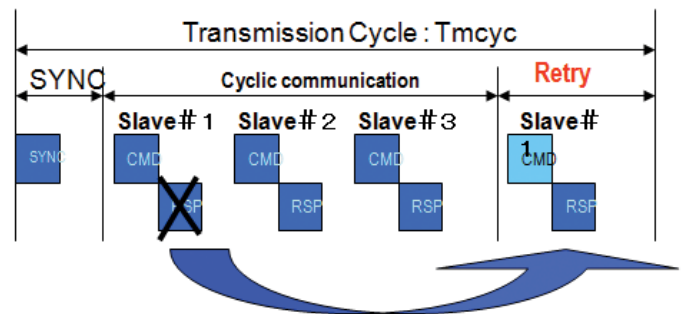
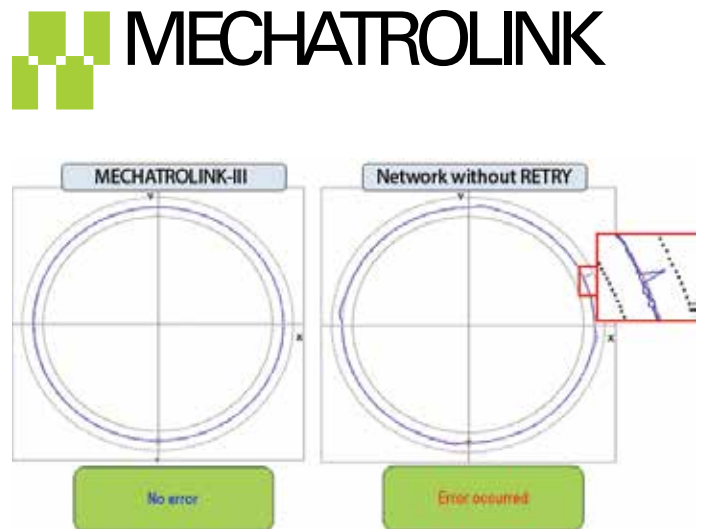

Controller-Centric Commissioning

The MECHATROLINK motion network provides a conduit to configure the machine from a single location with one software tool, resulting in minimal commissioning time.

Remote I/O

Interface with the system using Yaskawa's own MECHATROLINK I/O, VIPA SLIO I/O, or third-party remote I/O modules from Phoenix, Wago or Opto 22 via MECHATROLINK or Ethernet.

Local I/O

MPiec controller hardware can be expanded to include your choice of eight option cards to accommodate most automation requirements.

IEC on the Drive

The MP2600iec Motion Controller offers a compact controller/amplifier combination, providing standardized programming on Yaskawa's latest high quality servo system.

Scalability

The use of one software platform for all MPiec machine controllers enables users to easily scale up their applications from single to multi-axis control.

Programmable Amplifier Outputs

The controller can operate local outputs on a SERVOPACK, reducing panel cost and saving panel space when only a few outputs are necessary.

Web-based System Access

MPiec Machine Controllers have a built-in web interface for better system access. Plug into a local network and adjust parameters using any web browser, or log in anywhere in the world via a secure internet connection.

- Monitor vital control status, diagnostic and alarm information
- Change settings or update firmware remotely
- Connect via cable and enjoy on-site control with your favorite browser, or access from any remote location
- Connect via Ethernet on a computer, an Android™ or Apple® tablet



MPiec Machine Controllers

CONTROLLER HARDWARE

MPiec Machine Controllers offer a wide range of hardware for applications ranging from 1 to 62 axes. All controllers are equipped with the reliable MECHATROLINK motion network.

MP2600iec

- Processor Speed: 200 MHz
- Motion Network: Dual Port RAM access
- Motion Networks Speed: As fast as 1 ms
- Network Capability: OPC, EtherNet/IP, Modbus TCP
- Axis Count: 1.5
- Option Card Slots: None (On board I/O)



MP2300Siec / MP2310iec

- Processor Speed: 240 MHz
- Motion Network: MECHATROLINK-II
- Motion Networks Speed: As fast as 0.5 ms
- Network Capability: OPC, EtherNet/IP, Modbus TCP
- Axis Count: 4, 8 or 16
- Option Card Slots: 1 or 3



MP3300iec

- Processor Speed: 400MHz
- Motion Network: MECHATROLINK-III
- Motion Network Speed: As fast as 0.25 ms
- Network Capability: OPC, EtherNet/IP, Modbus TCP
- Axis Count: 4, 8 or 20
- Option Card Slots: 1 or 3



MP3200iec

- Processor Speed: 1 GHz
- Motion Network: MECHATROLINK-III
- Motion Networks Speed: As fast as 0.25 ms
- Network Capability: OPC, EtherNet/IP, Modbus TCP
- Axis Count: 4, 8, 16, 32 or 62
- Option Card Slots: 3, 5 or 8



System Components

MECHATROLINK-III Network Components				
DESCRIPTION		PART NUMBER	NOTES	
MP3200iec	CPU Module	PMC-U-MP320 □□	□□: Maximum number of MECHATROLINK Axes: 04:4 • 08: 8 • 16:16 • 32:32 • 62:62	
	Power Supply Module	JEPMC-PS□3012-E	□: Input Power D: 24 VDC • A: 100/200 VAC	
	Option Module Rack	JEPMC-BUB300□-E	For optional I/O modules	□: Slot number: 3:3 slots • 5: 5 Slots • 8: 8 Slots
MP3300iec	CPU Module	PMC-U-MP330 □□	□□: Maximum number of MECHATROLINK Axes: 04:4 • 08: 8 • 20:20	
	24VDC Power and Option Rack	JEPMC-BU330□-E	□□: Number of slots: 4: 1 slot, 3: 3 slots	
MECHATROLINK-II Network Components				
DESCRIPTION		PART NUMBER	NOTES	
MP2300Slec	Controller	PMC-U-MP23S □□	without I/O module	
		PMC-U-MP23S □□L1	with factory installed LIO-01	
		PMC-U-MP23S □□L2	with factory installed LIO-02	
MP2310iec	Controller	PMC-U-MP231 □□	without I/O module	
□□: Maximum number of MECHATROLINK Axes: 04:4 • 08: 8 • 16:16				
Single-Axis Controller Option with SERVOPACK				
DESCRIPTION		PART NUMBER	NOTES	
MP2600iec	Controller/SERVOPACK	SGDV□□□□E1A002000300	□□□□: denotes output capacity and voltage of Σ-V SERVOPACK	
MECHATROLINK-III Network Components				
DESCRIPTION		PART NUMBER	NOTES	
Software	MotionWorks IEC Express	PDE-U-IE□Sx	□: Software Version: 2:2 - 3:3	x: License Type: E: Electronic
	MotionWorks IEC Pro	PDE-U-IE□Px	□: Software Version: 2:2 - 3:3	x: License Type: E: Electronic • H: Floating License
	MotionWorks IEC OPC Server	PDE-U-OPCPx	x: Licenses: A:1 • B:5 • C:10 • D: 20	
Option Cards (for MP3200iec, MP3300iec, MP2300Slec, MP2310iec)	JAPMC-AN2300	Analog Inputs (AI-01)	(8) channels; +/- 10V @ 16-bit resolution @ 20kΩ or 4-20mA @ 15-bit @ 250Ω	
	JAPMC-AN2310	Analog Outputs (AO-01)	(4) channels; +/- 10V @16-bit resolution; 5mA max load current	
	JAPMC-DO2300	Output Module (DO-01)	(64) 24VDC sinking outputs; IOmA/output	
	JAPMC-IO2300-E	I/O Module (LIO-01)	(16) 24VDC sinking or sourcing inputs; (16) 24VDC sinking outputs; IOmA/output;(1) Encoder Counter; A/B/C channels; differential; latch response time 5μs; max frequency 500kHz	
	JAPMC-IO2301-E	I/O Module (LIO-02)	(16) 24VDC sinking or sourcing inputs; (16) 24VDC sinking outputs; IOmA/output; (1) Encoder Counter; A/B/C channels; differential; latch response time 5μs; max frequency 500kHz	
	JAPMC-IO2303	I/O Module (LIO-04)	(32) 24VDC sinking or sourcing inputs; (32) 24VDC sinking outputs; IOmA/output	
	JAPMC-IO2304	I/O Module (LIO-05)	(32) 24VDC sinking or sourcing inputs; (32) 24VDC sourcing outputs; 100mA/output	
	JAPMC-IO2305-E	Multi-Function (LIO-06) I/O Option Module	Analog/Digital/Encoder	
	JAPMC-CM2301-E	Communications Option (2BIF-Y1)	(1) Ethernet port 10 MBit; (1) RS232 port	
Terminal Block Conversion Kits	CBK-U-MP2A-□□	For LIO-01/02	□□: Cable Length: A5:0.5m • 01: 1.0m • 03: 3.0m	
	CBK-U-MP2B-□□	For LIO-04/05/06/ MP2600iec		
	SBK-U-VBA-□□	For SGD Servo Amp- CNI		

MPiec Machine Controllers

VIPA SLIO I/O

If you've wished that Input/Output could be **FASTER** and **EASIER**, VIPA SLIO is for you. Yaskawa's new decentralized I/O system is full of features that make connection simpler and I/O functions more efficient.

Easy Web Interface

SLIO diagnostic and status information is accessible through a web interface, delivering complete system status data from any EtherNet/IP or Modbus TCP fieldbus module into a standard browser. Remote access via Internet is also available.



High Speed Backplane Bus

Achieve reaction times as fast as 20 microseconds with VIPA SLIO's high speed backplane bus. Connect as many as 64 modules at a time, while maintaining speeds up to 48 Mbit/s.



One-touch Hardware Configurator

VIPA SLIO puts an end to hours of tedious manual I/O configuration. The MotionWorks IEC VIPA SLIO Hardware Configurator sets up a complete I/O system with the touch of a single button.

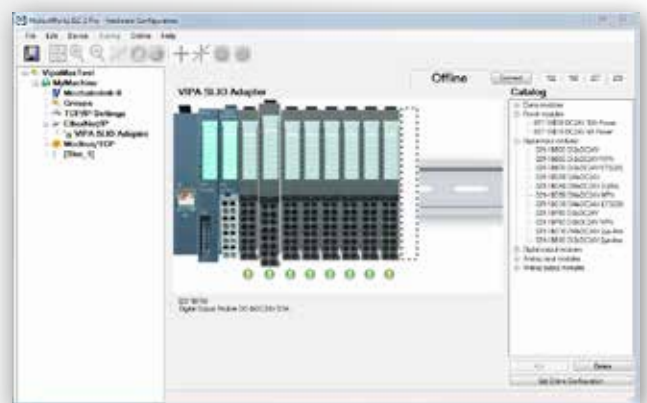

Compact

Intelligent

Flexible

Installer Friendly Design

Engineered for error-free installation, SLIO can be installed by an average technician without consulting a machine designer or installation engineer.

- Easy, safe assembly with no tools required.
- Staircase-shaped wiring level saves space, eases connection
- Clamp terminal assignment is clearly printed on each module
- Labeling strips clearly indicate module function, replace easily after a reconfiguration

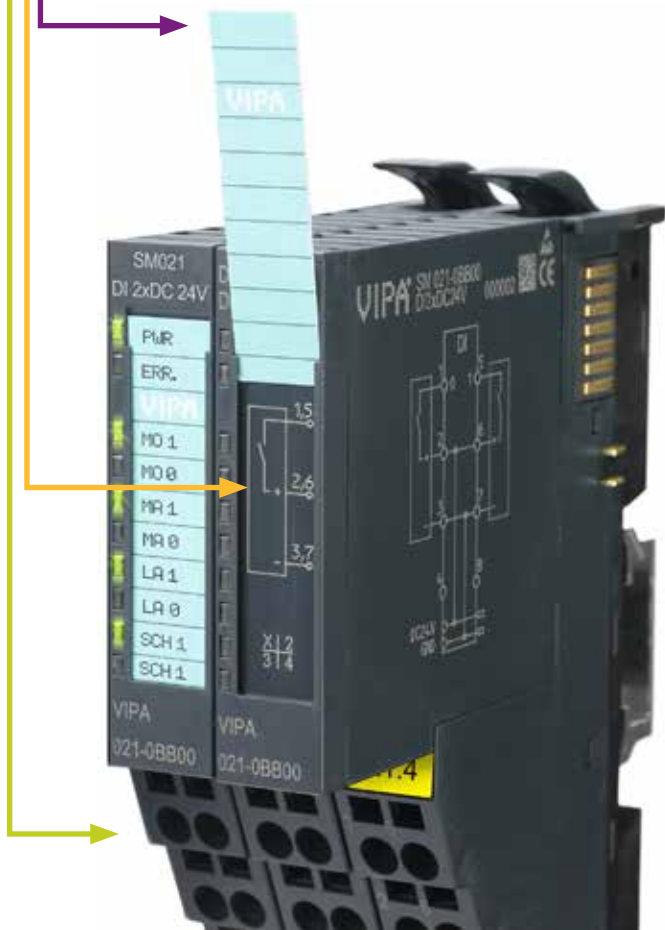

The SLIO system is designed for customers who want to modularize and standardize, yet remain flexible at the same time. SLIO can help reduce setup time and minimize user errors.

Reconfigure Without Rewiring

Updating or amending a SLIO system is as easy as removing an existing module and snapping in a new one. System functions can be changed without removing the wiring from the contact block.



VIPA SLIO I/O

Modular Construction for Quick Assembly

Compact: Width 12.9 mm, height 109 mm, depth 76.5 mm

Standardized: Direct mounting on 35 mm standard profile rail

Extendable: The flexible design of SLIO makes it easy to expand as needed; add up to 64 signal and function modules per interface.

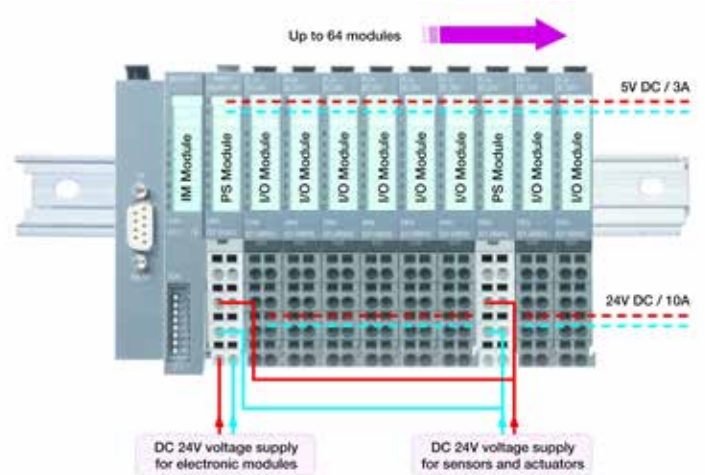

Interchangeable Function Modules

Choose from a selection of 120+ interchangeable signal and function modules, ready to be snapped into an existing contact block for instant reconfiguration to a new function.

- Analog and digital inputs and outputs
- Communication processor modules
- Coupler modules
- Potential distributor modules
- Power modules
- Temperature modules
- Future modules add tomorrow's functions with the same snap-in interconnection

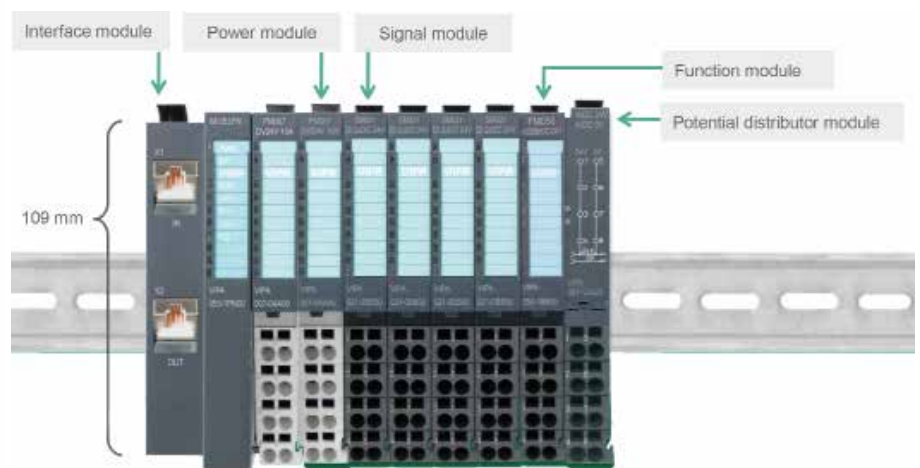

Modules Supported by MotionWorks IEC

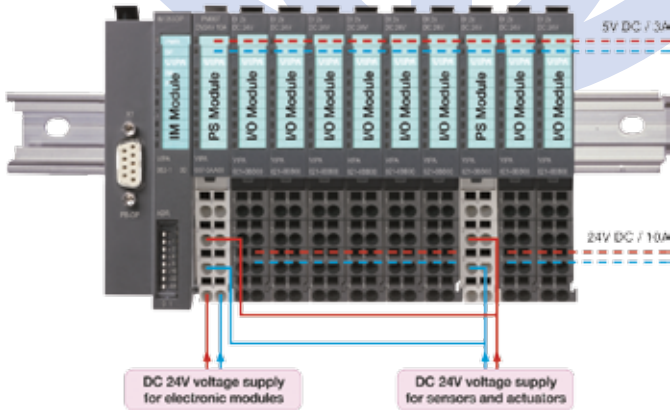

Fieldbus Module

EtherNet/IP, 10 A (3A bus supply)

Power Modules

DC 24V, 10A

DC 24V, 4 A (2A bus supply)

Digital Input

	2X	4X	8X
DC 24 V	•	•	•
DC 24 V (2us to 4ms)	•	•	
DC 24 V (3 wire)		•	
DC 24 V (NPN)	•	•	•

Digital Output

	2X	4X	8X
DC 24 V, 0.5 A	•	•	•
DC 24 V, 2A	•	•	
DC 24 V, 0.5 A (NPN)	•	•	•
DC 24 V, 0.5 A (PWM)	•		
DC 30 V/AC 230 V/3A (Relay)	•	•	

Analog Input

	1X	2X	4X
0 to 10 V, 12 Bit		•	•
0 (4) to 20 mA, 12 Bit		•	•
0 (4) to 20 mA (2 wire), 12 Bit		•	
+/- 10 V, 12 Bit		•	•
Thermocouple, 16 Bit		•	
Ohm Resistance, 16 Bit			•
0 to 10 V, 16 Bit		•	•
0 (4) to 20 mA, 16 Bit		•	•
+/- 10 V, 16 Bit		•	

Analog Output

	1X	2X	4X
0 to 10 V, 12 Bit		•	•
0 (4) to 20 mA, 12 Bit		•	•
+/- 10 V, 12 Bit		•	•
0 to 10 V, 16 Bit		•	•
+/- 10 V, 16 Bit		•	•

SIGMA-5 SERVOS



One Choice to Get Everything in Motion.

The machines you design need to be flexible in function, easy to operate, physically compact and cost effective. It's easy to achieve one of these attributes, but your customers demand them all. Now.

Tomorrow's Challenge

The high expectations continue long after your machine leaves the drawing board. You'll also need superior product reliability and years of consistent performance, plus support that sustains your user through years ... possibly even decades ... of successful production.

What if ...

- The mechanical complexity of your machine could be reduced while at the same time allowing for increased flexibility?
- Your required engineering time to commission a machine could be cut in half?
- You could build a quieter, more efficient machine that always delivers optimal performance?

Simplify your machine design while improving its overall effectiveness.

Sigma-5 Servos: In Tune with Your Needs

After 25 years of innovation and five generations of servo systems, Yaskawa has a very precise solution for automation's toughest challenges. It's coupled with the confidence you gain from a motion control vendor that ships more servo axes annually than any other company worldwide.

Tuning-less Operation

Every Sigma-5 SERVOPACK is equipped with a tuning-less function that is enabled from the moment you pull it out of the box. This function allows the amplifier to detect load inertia and automatically adjust the servo gains at the update rate of the position loop (a lightning fast 62.5 microseconds.)

You'll never need to adjust the servo tuning gains again. The amplifier compensates for changes in load inertia, wear-related changes to machine mechanics and other variations that occur from machine to machine.

Vibration Suppression

Sigma-5 SERVOPACKs neutralize vibration caused by the motion of the motor and natural resonances within the machine. It detects actual vibration frequencies and cancels them out of the motion command, creating a new machine cycle that is quicker, quieter, and more efficient.



Without Vibration
Suppression



With Vibration
Suppression

One Choice for All Applications

The complete Sigma-5 product portfolio spans a wide power range, allowing users to standardize on the same family of motors and amplifiers. Rotary, direct drive and linear servo motors are all part of the Sigma-5 family.



99.993% Quality

In a recent internal study of 150,000 servo motors shipped, Yaskawa found that only 10 were returned for warranty repair.

PACKED WITH PERFORMANCE

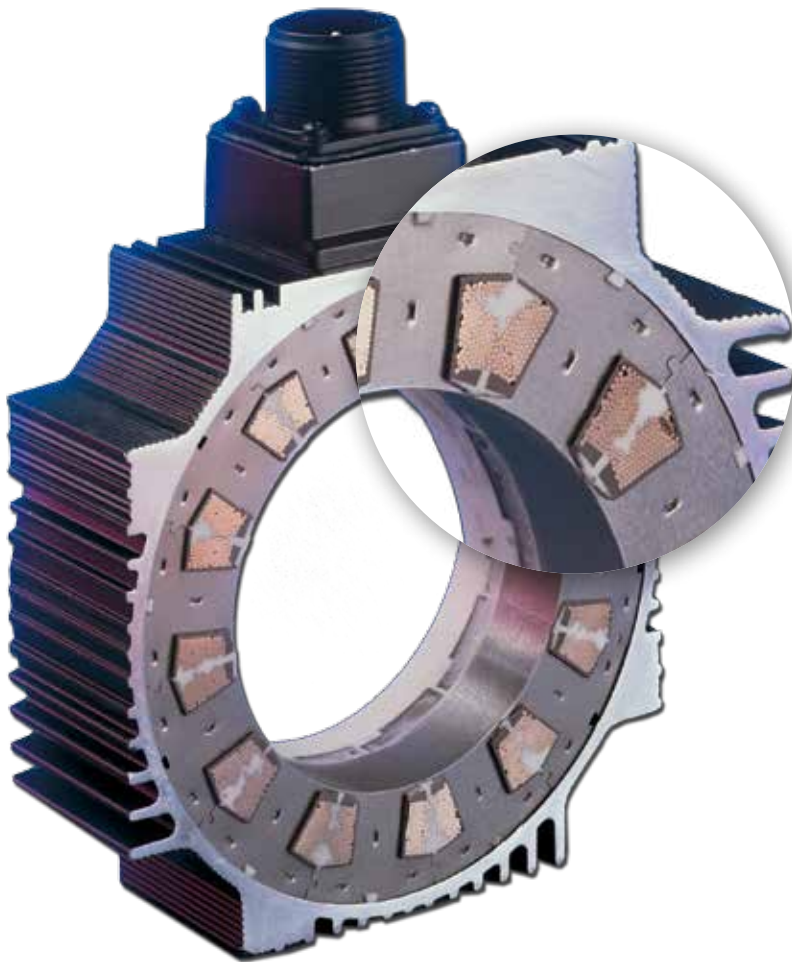

More torque in less space, for an easier fit in your tightest application.

- Yaskawa's segmented stator core design and automated winding techniques pack nearly twice the copper into the stator gap, for much more torque output from every square millimeter of space.
- Encapsulated windings prevent shorts between windings, improving heat dissipation.
- Precise machining is used to minimize the air gap between rotor magnets and stator windings, for higher running torque and reduced cogging torque.
- By reducing the space taken up by the end turns of the winding, overall motor length is significantly reduced.
- Neodymium-Iron-Boron rotor magnets optimize flux density in the motor.





Motors, Amps Paired for Performance

Yaskawa optimizes the efficiency of your system by designing and testing servo motors and amplifiers jointly. This minimizes failures caused by:

- Motor overheating
- Motor runaway
- Encoder signal loss
- System commissioning errors
- Incompatible motor/drive combinations

Eliminate Mechanical Breakdowns

Simplify your machine's design, decrease part counts and cut assembly time by replacing mechanical linkages with reliable, flexible servo control.

- Designed to accommodate up to a 20:1 inertia mismatch
- Reduce gearbox size, or eliminate gearboxes altogether
- Reduce maintenance points in machinery and improve safety



Wide Range

The variety of motor form factors and options allows for flexibility in machine design.

Smart and Accurate

Serial encoders store motor parameters, making system startup quick and easy. System accuracy is improved with 20-bit resolution.

Absolute Standard

All Sigma-5 motors come equipped with absolute encoders, eliminating costly switches and complicated homing routines.

Sigma-5 Servo Motors

SMALL CAPACITY

Sigma-5 series rotary servo motors feature a wide range of outputs, down to 3W. 20-bit absolute feedback is standard on every servo, including low and medium inertia models.

Small Capacity, Low Inertia



SGMMV

- 3 W to 30 W
- 24/48 VDC Input
- 100/200 VAC Input
- 17-bit absolute feedback



SGMAV

- 50W to 1kW
- 100/200 VAC Input
- IP65 Protection
- 20-bit absolute feedback

Small Capacity, Medium Inertia



SGMJV

- 50W to 750W
- 100/200 VAC Input
- IP65 Protection
- 20-bit absolute feedback



SGMPH

- 50W to 750W
- 100/200 VAC Input
- IP65 Protection
- 20-bit absolute feedback
- Half the overall length of a conventional motor

Model Number Designation

SGMMV - A1 A 2 A 2 1

SGMMV

Rated Output
 B3: 3.3W A1: 10W
 B5: 5.5W A2: 20W
 B9: 11W A3: 30W

Power Supply Voltage
 A: 200VAC
 E: 24VDC / 48VDC

Serial Encoder
 2: 17-bit absolute

Options
 1: Standard
 C: 24VDC Brake

Shaft End
 2: Straight
 C: Straight w/flat seat

Design Revision
 A: Standard

SGM□V - 01 A 3 A 6 1

SGMJV/SGMAV

Rated Output
 A5: 50W 04:400W
 01: 100W 06:
 600W
 C2: 150W 08: 750W
 02: 200W 10: 1.0kW

Power Supply Voltage
 A: 200VAC

Encoder
 3: 20-bit absolute
 D: 20-bit incremental
 A: 13-bit incremental

Options
 1: Standard
 C: 24VDC Brake
 S: Shaft Seal
 E: Shaft Seal & Brake

Shaft End
 6 Straight with key and tap
 2: Straight w/o key

Design Revision
 A: Standard

SGMPH - 01 A A E 4 1

SGMPH

Rated Output
 01: 100W 08: 750W
 02: 200W 15: 1.5kW
 04: 400W

Power Supply voltage
 A: 200VAC
 B: 100VAC





Encoder
 A: 13-bit incremental
 B: 16-bit absolute

Options
 1: Standard
 C: 24VDC Brake
 S: Shaft Seal
 E: Shaft Seal & Brake

Shaft End
 4: Straight with keyway

Design Revision
 E: Standard

Small Capacity Model Specifications

Rotary Servomotor Model	Rated Power	Rated Torque	Peak Torque	Rated Speed	Max Speed	Rotary Inertia	SERVOPACK Model: SGDV-□□□□				
		N-m	N-m	rpm	rpm	kg-cm ²	24/48 VDC	100 VAC	200 VAC	400 VAC	
 <p>SGMMV Low Inertia Ultra-Small Capacity</p>	SGMMV-B3E	3.3 W	0.0105	0.0263	3000	6000	0.000441	1R7E	N/A	N/A	N/A
	SGMMV-B5E	5.5 W	0.0175	0.0438	3000	6000	0.000796	1R7E			
	SGMMV-B9E	11 W	0.0350	0.0875	3000	6000	0.002210	1R7E			
	SGMMV-A1A	10 W	0.0318	0.0955	3000	6000	0.000272	2R9E	R90F	R90A	
	SGMMV-A2A	20 W	0.0637	0.1910	3000	6000	0.000466	2R9E	R90F	R90A	
	SGMMV-A3A	30 W	0.0955	0.2860	3000	6000	0.000668	2R9E	2R1F	1R6A	
 <p>SGMAV Low Inertia Small Capacity</p>	SGMAV-A5A	50 W	0.159	0.477	3000	6000	0.0242	N/A	R70F	R70A	N/A
	SGMAV-01A	100 W	0.318	0.955	3000	6000	0.0380		R90F	R90A	
	SGMAV-C2A	150 W	0.477	1.43	3000	6000	0.0531		2R1F	1R6A	
	SGMAV-02A	200 W	0.637	1.91	3000	6000	0.116		2R1F	1R6A	
	SGMAV-04A	400 W	1.27	3.82	3000	6000	0.190		2R8F	2R8A	
	SGMAV-06A	550 W	1.75	5.25	3000	6000	0.326		N/A	5R5A	
	SGMAV-08A	750 W	2.39	7.16	3000	6000	0.769			5R5A	
	SGMAV-10A	1.0 kW	3.18	9.55	3000	6000	1.20			120A	
 <p>SGMJV Medium Inertia Small Capacity</p>	SGMJV-A5A	50 W	0.159	0.557	3000	6000	0.0414	N/A	R70F	R70A	N/A
	SGMJV-01A	100 W	0.318	1.11	3000	6000	0.0665		R90F	R90A	
	SGMJV-C2A	150 W	0.477	1.67	3000	6000	0.0883		2R1F	1R6A	
	SGMJV-02A	200 W	0.637	2.23	3000	6000	0.259		2R1F	1R6A	
	SGMJV-04A	400 W	1.27	4.46	3000	6000	0.442		2R8F	2R8A	
	SGMJV-06A	550 W	1.91	6.69	3000	6000	0.667		N/A	5R5A	
	SGMJV-08A	750 W	2.39	8.36	3000	6000	1.57			5R5A	
 <p>SGMPH Medium Inertia Small Capacity</p>	SGMPH-01B	100 W	0.32	0.960	3000	5000	0.0491	N/A	R90F	N/A	N/A
	SGMPH-02B	200 W	0.64	1.91	3000	5000	0.193		2R8F		
	SGMPH-01A	100 W	0.32	0.960	3000	5000	0.0491		N/A	R90A	
	SGMPH-02A	200 W	0.64	1.91	3000	5000	0.193			2R8A	
	SGMPH-04A	400 W	1.27	3.82	3000	5000	0.331			2R8F	
	SGMPH-08A	750 W	2.39	7.10	3000	5000	2.10		N/A	5R5A	
	SGMPH-15A	1.5 kW	4.77	14.3	3000	5000	4.02			120A	

Sigma-5 Servo Motors

MEDIUM/LARGE CAPACITY

Sigma-5 medium and large capacity rotary servo motors feature a wide range of outputs between 300W to 55kW.

Medium Capacity, Low Inertia



SGMGV

- 300W to 15kW
- 200/400 VAC Input
- IP67 Protection
- 20-bit absolute feedback

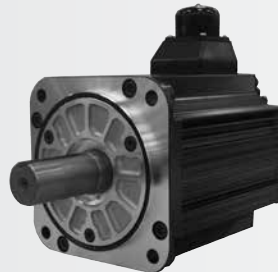

SGMSV

- 1kW to 7kW
- 200/400 VAC Input
- IP67 Protection
- 20-bit absolute feedback

Large Capacity, Medium Inertia





SGMVV

- 22kW to 55kW
- 200/400 VAC Input
- 20-bit absolute feedback
- Permanent Magnet Design

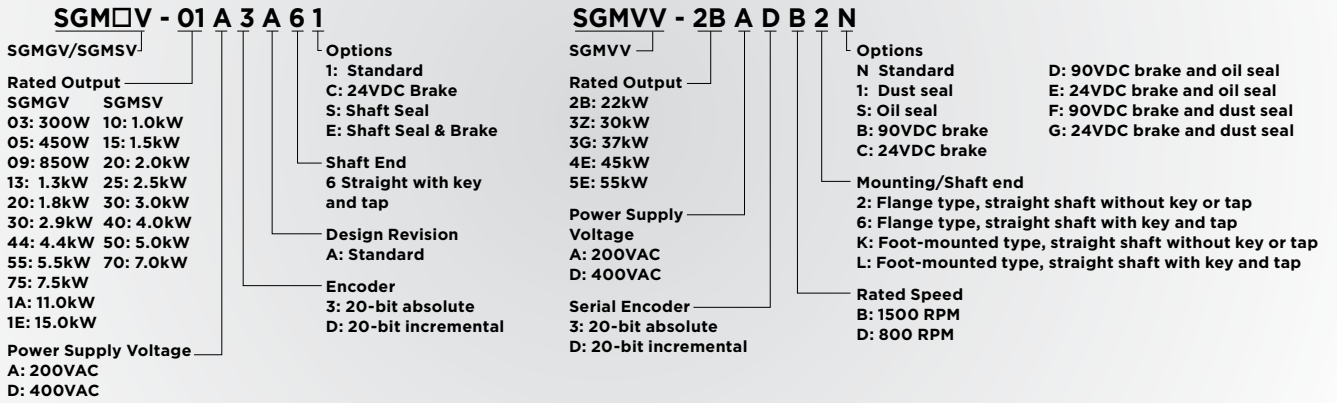
Model Number Designation



Medium/Large Model Specifications

Rotary Servomotor Model	Rated Power	Rated Torque	Peak Torque	Rated Speed	Max Speed	Rotary Inertia	SERVOPACK Model: SGMV-□□□□				
							24/48 VDC	100 VAC	200 VAC	400 VAC	
 <p>SGMSV Low Inertia Medium Capacity</p>	SGMSV-10□	1.0 kW	3.18	9.54	3000	6000	1.74	N/A	N/A	7R6A	3R5D
	SGMSV-15□	1.5 kW	4.90	14.7	3000	5000	2.00			120A	5R4D
	SGMSV-20□	2.0 kW	6.36	19.1	3000	5000	2.47			180A	8R4D
	SGMSV-25□	2.5 kW	7.96	23.9	3000	5000	3.19			200A	120D
	SGMSV-30□	3.0 kW	9.80	29.4	3000	5000	7.00			200A	120D
	SGMSV-40□	4.0 kW	12.6	37.8	3000	5000	9.60			330A	170D
	SGMSV-50□	5.0 kW	15.8	47.6	3000	5000	12.3			330A	170D
	SGMSV-70A	7.0 kW	22.3	54.0	3000	5000	12.3			550A	N/A
 <p>SGMGV Medium Inertia Medium Capacity</p>	SGMGV-03□	300 W	1.96	5.88	1500	3000	2.48	N/A	N/A	3R8A	1R9D
	SGMGV-05□	450 W	2.86	8.92	1500	3000	3.33			3R8A	1R9D
	SGMGV-09□	850 W	5.39	13.8	1500	3000	13.9			7R6A	3R5D
	SGMGV-13□	1.3 kW	8.34	23.3	1500	3000	19.9			120A	5R4D
	SGMGV-20□	1.8 kW	11.5	28.7	1500	3000	26.0			180A	8R4D
	SGMGV-30□	2.9 kW	18.6	45.1	1500	3000	46.0			330A	120D
	SGMGV-44□	4.4 kW	28.4	71.1	1500	3000	67.5			330A	170D
	SGMGV-55□	5.5 kW	35.0	87.6	1500	3000	89.0			470A	210D
	SGMGV-75□	7.5 kW	48.0	119	1500	3000	125			550A	260D
	SGMGV-1A□	11 kW	70.0	175	1500	2000	242			590A	280D
SGMGV-1E□	15 kW	95.4	224	1500	2000	303	780A	370D			
 <p>SGMVV Medium Inertia Large Capacity</p>	SGMVV-2BA□B	22 kW	140	350	1500	2000	366	N/A	N/A	121H1	N/A
	SGMVV-3ZA□B	30 kW	191	478	1500	2000	498			161H1	
	SGMVV-3GA□B	37 kW	236	589	1500	2000	595			201H1	
	SGMVV-2BA□D	22 kW	262	526	800	1300	705			121H1	
	SGMVV-3ZA□D	30 kW	358	752	800	1300	1290			161H1	
	SGMVV-3GA□D	37 kW	442	930	800	1300	1564			201H1	
	SGMVV-2BD□B	22 kW	140	350	1500	2000	366			750J ¹	
	SGMVV-3ZD□B	30 kW	191	478	1500	2000	498			750J ¹	
	SGMVV-3GD□B	37 kW	236	589	1500	2000	595			101J ¹	
	SGMVV-4ED□B	45 kW	286	715	1500	2000	1071			131J ¹	
	SGMVV-5ED□B	55 kW	350	875	1500	2000	1290			131J ¹	
	SGMVV-2BD□D	22 kW	262	526	800	1300	705			750J ¹	
	SGMVV-3ZD□D	30 kW	358	752	800	1300	1290			750J ¹	
	SGMVV-3GD□D	37 kW	442	930	800	1300	1564			101J ¹	
	SGMVV-4ED□D	45 kW	537	1182	800	1300	1804			131J ¹	

¹: Separate converter unit required. See product manual for more details.

DIRECT DRIVE SERVO MOTORS

Reduce Downtime

By eliminating gear reduction and creating a direct coupling to the machine load, direct drive motors simplify your machine's design. Eliminating couplings and other components in the machine's mechanical transmission will ultimately lead to fewer breakdowns and long-term reliability you can trust.

Increase Performance

Direct drive motors eliminate the inefficiencies that develop as mechanical transmission components wear over time. Say goodbye to mechanical backlash as well. As compliance is reduced, the responsiveness of the servo system can be dramatically improved.

Reduce Size and Cost

Directly coupling a compact direct drive servo motor to your machine load will save physical space, which can lead to a more space-efficient machine. When precision gearheads and other mechanical transmission components are gone, the cost of your machine will go down as well.

Boost the Quality of Your Design

Implementing direct drive motor technology leads to a host of improvements in the quality of your machine designs.

- Machines with direct drive motors typically emit less audible noise.
- Eliminating mechanical transmissions reduces the need for preventive maintenance.
- Overall efficiency and performance can be significantly increased, leading to a lower long term cost.



Typical Applications

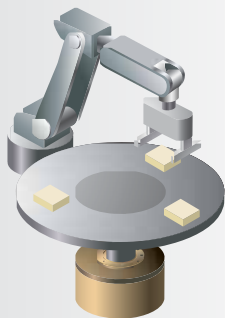

Rotary Table

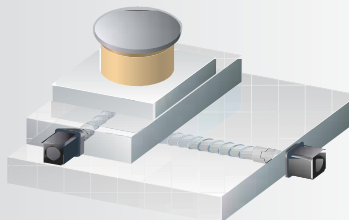

XY Table



Semiconductor Handling Robot

Model Number Designation

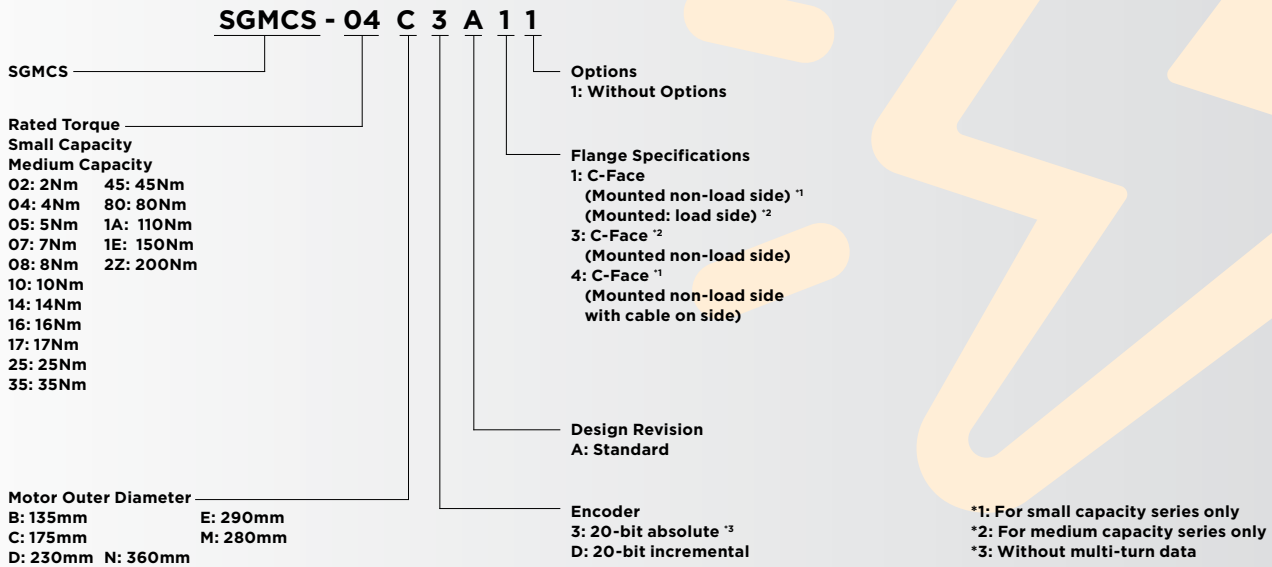

Medium/Large Model Specifications

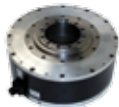
Rotary Servomotor Model	Rated Power	Rated Torque	Peak Torque	Rated Speed	Max Speed	Rotary Inertia	SERVOPACK Model: SGD□-□□□□		
		N-m	N-m	rpm	rpm	kg-cm ²	100 VAC	200 VAC	
 <p>SGMCS Small Capacity</p>	SGMCS-02B	42 W	2.0	6.0	200	500	28.0	2R1F	2R8A
	SGMCS-05B	105 W	5.0	15.0	200	500	51.0	2R1F	2R8A
	SGMCS-07B	147 W	7.0	21.0	200	500	77.0	2R1F	2R8A
	SGMCS-04C	84 W	4.0	12.0	200	500	77.0	2R8F	2R8A
	SGMCS-10C	209 W	10.0	30.0	200	400	140	2R8F	2R8A
	SGMCS-14C	293 W	14.0	42.0	200	300	220	2R8F	2R8A
	SGMCS-08D	168 W	8.0	24.0	200	500	285	2R8F	2R8A
	SGMCS-17D	356 W	17.0	51.0	200	350	510	2R8F	2R8A
	SGMCS-25D	393 W	25.0	75.0	150	250	750	2R8F	2R8A
	SGMCS-16E	335 W	16.0	48.0	200	500	930	2R8F	5R5A
SGMCS-35E	550 W	35.0	105	150	250	1430	2R8F	5R5A	
 <p>SGMCS Medium Capacity</p>	SGMCS-45M	707 W	45.0	135	150	300	388	N/A	7R6A
	SGMCS-80M	1.26 kW	80.0	240	150	300	627		120A
	SGMCS-80N	1.26 kW	80.0	240	150	300	865		120A
	SGMCS-1AM	1.73 kW	110	330	150	300	1360		180A
	SGMCS-1EN	2.36 kW	150	450	150	250	2470		200A
	SGMCS-2ZN	3.14 kW	200	600	150	250	3060		200A

Sigma-5 Servo Motors

LINEAR SERVO MOTORS

Yaskawa offers a full range of linear servo products that are designed to handle the most demanding applications.



SGLG: Coreless

- 200V windings
- 40 to 3000N of peak force
- Standard and high force magnetic ways
- Zero cogging for minimal force ripple



SGLF: Iron Core

- 200 or 400V windings
- 86 to 2400N of peak force
- 5 m/s peak speed

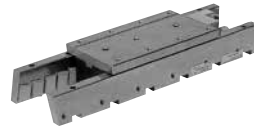

SGLT: Dual Magnet Iron Core

- 200V or 400V windings
- 380 to 7500N of peak force
- 5 m/s peak speed
- Very little cogging



Sigma Trac: Linear Motor Stage

- Factory assembled, integrated stage
- 200 or 400V windings
- Stroke lengths from 80mm to 2m
- 220 to 1200N of peak force
- Sub-micron repeatability

Model Number Designation

SGLG, SGLF, SGLT

Moving Coil

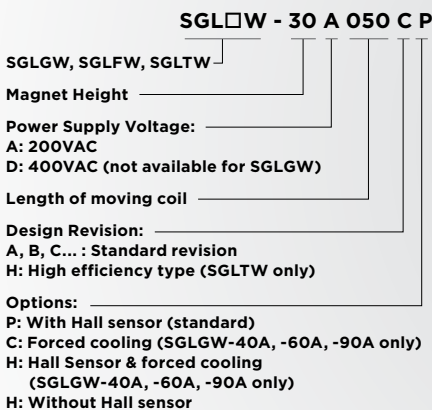

Magnetic Way

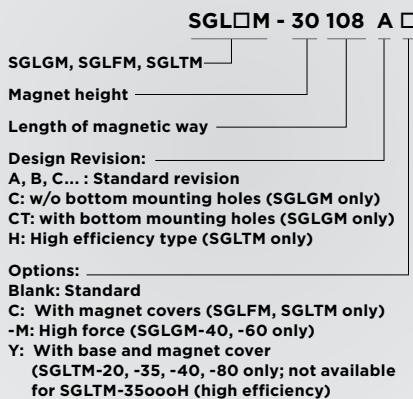

Sigma Trac

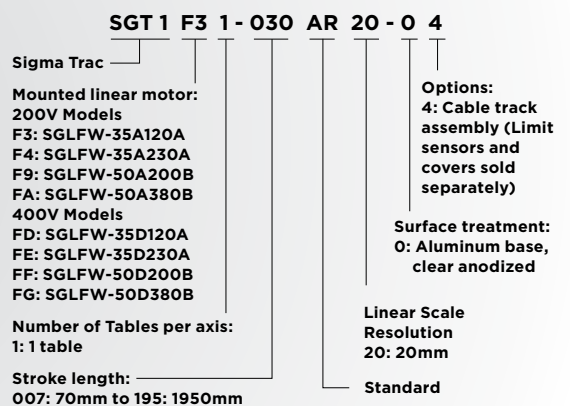

Need for Speed?

If your application requires linear speeds and accelerations that go beyond the capabilities of traditional mechanisms, take a look at Yaskawa linear motors.

More Performance

Direct coupling to the machine load eliminates mechanical linkages, significantly improving responsiveness and reliability.

Engineered Solutions

The Sigma Trac linear motor stage reduces machine design complexity and commissioning time.

Medium/Large Model Specifications

Linear Servomotor Coil Model		Rated Force N	Peak Force N	Rated Speed m/s	Peak Speed m/s	Moving Coil Mass kg	SERVOPACK Model: SGDV-□□□□		
							100 VAC	200 VAC	400 VAC
 <p>SGLGW Coreless Type with Standard Magnetic Way</p>	SGLGW-30A050CP	12.5	40	1.5	5	0.10	R70F	R70A	N/A
	SGLGW-30A080CP	25	80	1.5	5	0.15	R90F	R90A	
	SGLGW-40A140CP	47	140	2.0	5	0.34	R90F	R90A	
	SGLGW-40A253CP	93	280	2.0	5	0.60	2R1F	1R6A	
	SGLGW-40A365CP	140	420	2.0	5	0.87	2R1F	1R6A	
	SGLGW-60A140CP	70	220	2.3	4.8	0.42	2R8F	2R8A	
	SGLGW-60A253CP	140	440	2.3	4.8	0.76	2R8F	2R8A	
	SGLGW-60A365CP	210	660	2.3	4.8	1.1	N/A	5R5A	
	SGLGW-90A200CP	325	1300	1.8	4	2.2		120A	
	SGLGW-90A370CP	550	2200	1.8	4	3.6		180A	
SGLGW-90A535CP	750	3000	1.8	4	4.9	200A			
 <p>SGLGW Coreless Type with High Force Magnetic Way</p>	SGLGW-40A140CP	57	230	1.0	4.2	0.34	2R1F	1R6A	N/A
	SGLGW-60A140CP	85	360	1.0	4.2	0.60	2R1F	1R6A	
	SGLGW-40A253CP	114	460	1.0	4.2	0.87	2R8F	2R8A	
	SGLGW-40A365CP	171	690	1.0	4.2	0.42	N/A	3R8A	
	SGLGW-60A253CP	170	720	1.0	4.2	0.76		3R8A	
	SGLGW-60A365CP	255	1080	1.0	4.2	1.1		7R6A	
 <p>SGLFW Iron Core Type</p>	SGLFW-20□□090AP	25	86	5.0	5.0	0.70	2R1F	1R6A	N/A
	SGLFW-20□□120AP	40	125	3.5	5.0	0.90	2R1F	1R6A	
	SGLFW-35□□120AP	80	220	2.5	5.0	1.3	2R1F	1R6A	1R9D
	SGLFW-35□□230AP	160	440	3.0	5.0	2.3	N/A	3R8A	1R9D
	SGLFW-50□□200BP	280	600	1.5	5.0	3.5		5R5A	3R5D
	SGLFW-50□□380BP	560	1200	1.5	5.0	6.9		120A	5R4D
	SGLFW-1Z□□200BP	560	1200	1.5	4.9	6.4		120A	5R4D
SGLFW-1Z□□380BP	1120	2400	1.5	4.9	11.5	200A		120D	
 <p>SGLTW Dual Magnet Iron Core Type</p>	SGLTW-20A170AP	130	380	3.0	5.0	2.5	N/A	3R8A	N/A
	SGLTW-35A170AP	220	660	2.5	5.0	3.7		5R5A	
	SGLTW-35□□170HP	300	600	2.5	4.8	4.9		5R5A	3R5D
	SGLTW-50□□170HP	450	900	2.0	3.2	6.0		5R5A	3R5D
	SGLTW-20A320AP	250	760	3.0	5.0	4.6		7R6A	N/A
	SGLTW-20A460AP	380	1140	3.0	5.0	6.7		120A	
	SGLTW-35A320AP	440	1320	2.5	5.0	6.8		120A	
	SGLTW-35□□320HP	600	1200	2.0	4.8	8.8		120A	8R4D
	SGLTW-50□□320HP	900	1800	2.0	3.1	11.0		120A	8R4D
	SGLTW-35A460AP	670	2000	2.5	5.0	10.0		180A	N/A
	SGLTW-40□□400BP	670	2600	1.5	3.1	15.0		180A	120D
	SGLTW-40□□600BP	1000	4000	1.5	3.1	23.0		330A	170D
	SGLTW-80□□400BP	1300	5000	1.5	2.5	24.0		330A	170D
SGLTW-80□□600BP	2000	7500	1.5	2.5	35.0	550A	260D		
 <p>Sigma Trac Linear Motor Stage</p>	SGTIF31-□□□AR20-04	80	220	4.6	5.0	4.3	2R1F	1R6A	N/A
	SGTIF41-□□□AR20-04	160	440	5.0	5.0	6.6	N/A	3R8A	
	SGTIF91-□□□AR20-04	280	600	4.2	5.0	8.5		5R5A	
	SGTIFA1-□□□AR20-04	560	1200	4.4	5.0	14.5		120A	
	SGTIFD1-□□□AR20-04	80	220	4.6	5.0	4.3	N/A	N/A	1R9D
	SGTIFE1-□□□AR20-04	160	440	5.0	5.0	6.6		N/A	1R9D
	SGTIFF1-□□□AR20-04	280	600	4.2	5.0	8.5		N/A	3R5D
SGTIFG1-□□□AR20-04	560	1200	4.4	5.0	14.5	N/A	N/A	5R4D	

Product Overview

SIGMA-5 SERVOPACKS



Finely Tuned For Extra Productivity.

Every Sigma-5 rotary, direct drive and linear servo motor has a companion SERVOPACK, equipped with intelligent features which improve your machine's effectiveness.

Simplified Tuning

System tuning can be the most time-consuming part of commissioning a machine. To help, Yaskawa built a "tuning-less" function into every SERVOPACK that automatically optimizes the tuning gains of each servo axis in your application. Regardless of changes in machine load, run rate, or duty cycle, the Sigma-5 SERVOPACK adjusts to provide the highest levels of performance...and all without the need for operator effort.

Tuning-Less Function

Get up and running quickly

Right out of the box, the tuning-less function automatically compensates for mismatches in load to rotor inertia up to 20:1.

Setting time:
100 to 150 ms
range

Advanced Autotuning

Minimize setting time with less vibration

Advanced auto tuning automatically adjusts nearly 20 gain and filter parameters, including new feed-forward gain and friction compensation.

Setting time:
10 ms
range

One Parameter Tuning

Precise user-driven adjustment

Improve your machine's performance even further with easy fine-tuning adjustments that won't bury you in complex options.

Setting time:
0 to 4 ms
range



SERVOPACKs with features that amp up productivity

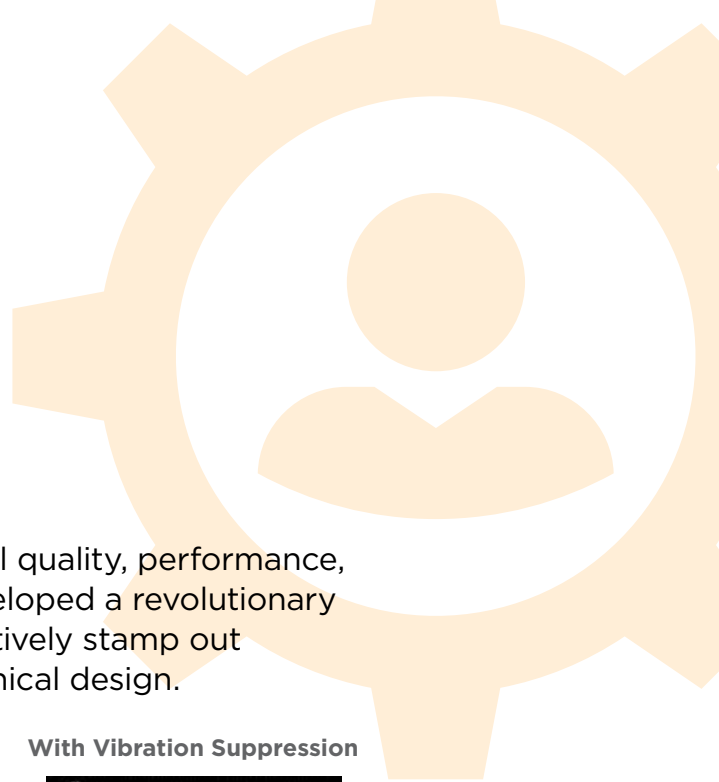

Vibration Suppression

Every motion-induced vibration affects the overall quality, performance, and efficiency of your machine. Yaskawa has developed a revolutionary set of vibration suppression algorithms that effectively stamp out vibrations automatically, regardless of the mechanical design.

Without Vibration Suppression

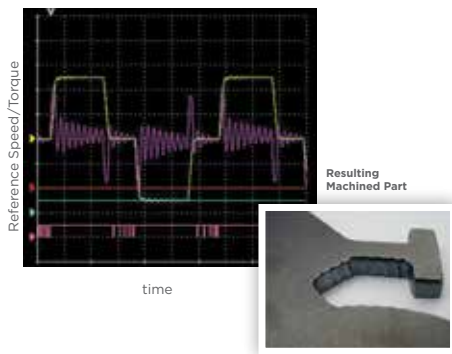

With Vibration Suppression

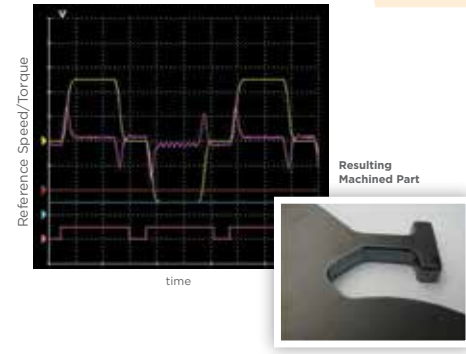

Servo Amplifier/Motor Matched Pairs

Sigma-5 SERVOPACKs are tested jointly with their corresponding servo motors to optimize the efficiency of the system. This minimizes failures caused by:

- Motor Overheating
- Motor Runaway
- Encoder Signal Loss
- System Commissioning Errors

Settling Time

Vibration suppression, model following and other performance enhancing algorithms are coupled with extremely high frequency response to allow for significant improvements in settling time.

Simpler Machine Commissioning

Automatic motor recognition by the SERVOPACK ensures proper installation.



FEATURE-PACKED FOR YOUR MACHINE

A choice of open protocol, high speed deterministic digital networks



MECHATROLINK

- Used with Yaskawa's full line of IEC61131-3 motion controllers
- Superior immunity to noise in challenging industrial environments
- Retry function minimizes data drop-outs

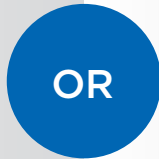

EtherCAT®

- Adheres to CoE device profile (CiA402)
- Distributed clock for synchronized operation
- Variety of system architectures (cascade, line, star, ring)

Functional Safety

A Safe Torque Off (STO) circuit is standard equipment in every SERVOPACK. Safety functions SS1 (Safe Stop 1), SS2 (Safe Stop 2), and SLS (Safe Limited Speed) are integrated with selection of an optional safety module

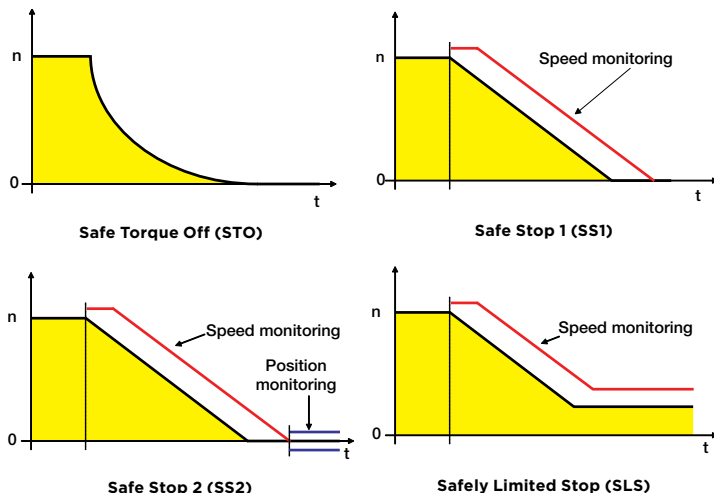

Primary Feedback Option

- 20-bit serial absolute encoder
- Motor data stored in the encoder
- Simplified cable design

Secondary Feedback Option (Full Closed Loop Control)

- Allows user to close position loop around secondary feedback device near the load.
- Helps eliminate the effects of mechanical compliance and thermal variances.
- Delivers more precise control and improved machine performance.

MP2600iec Single Axis Controller

- IEC61131-3 compatibility is your assurance that programs are developed and executed with predictable behavior.
- MotionWorks IEC software provides scalability between single and multi-axis control.
- EtherNet/IP and Modbus TCP connectivity links you to nearly every HMI and PLC on the market.
- A built-in web server offers standard controller diagnostic information, eliminating the need for special software for maintenance personnel.



SigmaLogic™ with EtherNet/IP

- Add On Instructions (AOIs) for use with Rockwell PLCs
- Dual EtherNet/IP ports onboard
- No Yaskawa software required
- Basic point to point moves, blended speed moves, homing, jogging, electronic gearing



Analog Voltage / Pulse Train

- +/- 10VDC Analog torque or velocity
- Pulse train reference
- Contact speed



Wide Range

A power range from 10W to 55kW, with 100-480 VAC operation.

Scaleable as Needs Change

Switching from a single axis controller to a multi axis model is easier, thanks to the fact that programming from a single axis SERVOPACK can be used in any Yaskawa multi-axis controller without revision.

Simple Commissioning

An automatic motor recognition function uses data resident within Yaskawa servo motors to configure a SERVOPACK for safe and effective operation.



ENGINEERED SOLUTIONS

Turning Servos into Services

You Need Solutions.

Today's machine builders and manufacturers need to bring new designs to market in months or weeks instead of years. At the same time, you no longer have the luxury of a large staff of engineers or the help of in-house experts in automation engineering.

The Challenge: Expertise.

Design and support of automation is a challenge to your resources. Your automation design must be immediately effective and reliable in the long run. There's simply no room for downtime, lost production or support difficulties down the line.

What if:

- You could add expert automation engineers to your staff at the exact moment you need them?
- You could hand off responsibility for designing and supporting your machine automation to someone you trusted?
- You could keep your engineering staff focused on areas where your company truly adds value?



More than 75% of manufacturers report a moderate to severe shortage of skilled resources*.

A Portfolio of Services

The experts at Yaskawa function as an extension of your engineering staff to create elegant, reliable automation.

We begin by understanding your application and process, the results you need to achieve, your time frame and cost structure. This level of understanding is what sets Yaskawa Engineered Systems apart, and makes us Capable of More.

Motion Application Services

Yaskawa's engineering expertise can be applied to any stage of machine development.

- System Concept Design
- Component Selection
- Electrical Design
- Mechatronic Design
- Machine Start-up
- Programming
- Optimization
- Troubleshooting

Software Development

Make Yaskawa's staff of programming professionals your software design and development team, and get a staff of engineers who understand proper software design and its impact on real-world machine operation.

Engineered Systems

Under the banner of Engineered Systems, Yaskawa offers a range of advanced products and services. They include complete machine retrofits, enclosure design and manufacturing, electromechanical assembly design and integration of Yaskawa servo technology into a "purpose built" mechanism for your application.

Purpose-Built Mechanisms: Yaskawa integrates servo technology into complete assemblies, including flexures, four-bar linkages, integrated ballscrew motors, and direct drive systems. Each mechanism is tested and characterized, with a documented, serialized fingerprint and a full warranty provided for each assembly. Yaskawa will continue to service and support each assembly for the entire life of your machine.

Systems Engineering: Yaskawa Engineered Systems provides valuable engineering expertise, including:

- Complete electrical enclosures and custom cables
- Retrofits and training for legacy equipment
- Upgrading your legacy machine controls and servos to the latest technologies
- 365 days a year, 24-hour support.

Yaskawa works with you during the entire cycle of a systems project, from defining scope and schedule to specifying components, electrical and software design, installation and line start-up. Our engineering expertise extends to support robot, servo, PLC, VFD, and controller products from Yaskawa and a wide variety of other suppliers.

*2014 Manufacturing Skills and Training Study, The Manufacturing Institute (affiliate of the National Association of Manufacturers). A copy of the report is available on request.



YASKAWA



Yaskawa America, Inc.
Drives & Motion Division

2121 Norman Drive South
Waukegan, IL 60085

1-800-YASKAWA (927-5292) • Local: 847-887-7000 • Fax: 1-847-887-7310

www.yaskawa.com

