

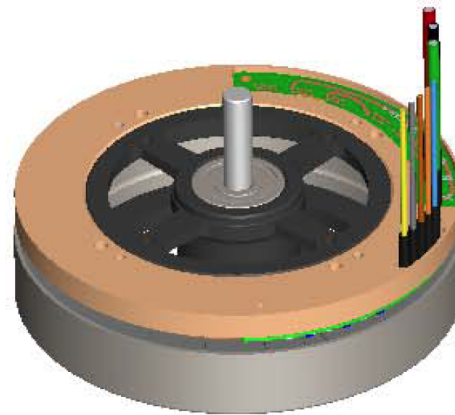

# TG30XX SERIES SUMMARY

The TG30XX series includes 12 high performance brushless permanent magnet machines designed with a common stator and mount architecture. There are 3 rotor options to allow optimization of weight and efficiency based on application torque requirements. The stator has 4 wiring options that enable a range of operating voltages.

Performance and mechanical parameters of the rotor options are summarized here. Consult the data sheet for details on the winding options.



PERFORMANCE SUMMARY <sup>1</sup>		TG303X	TG304X	TG305X
Max continuous torque	Nm	0.14	0.19	0.21
Max permissible speed	RPM	30600	28400	17900
Max continuous shaft power	W	103	132	151
Max efficiency	%	80%	82%	82%
Peak torque - 1s (3s)	Nm	0.41 (0.25)	0.53 (0.32)	0.62 (0.37)

MECHANICAL SUMMARY		TG303X	TG304X	TG305X
Max outer diameter	in (mm)	2.808 (71)	2.938 (75)	3.008 (76)
Through hole diameter	in (mm)	2.424 (62)	2.404 (61)	2.404 (61)
Total axial height	in (mm)	0.647 (16)	0.657 (17)	0.647 (16)
Partset mass (rotor & stator)	lbs (g)	0.254 (115)	0.311 (141)	0.34 (154)
Total motor assembly mass	lbs (g)	0.38 (171)	0.43 (197)	0.46 (210)
Rotor Inertia	lbm-ft <sup>2</sup> (kg-m <sup>2</sup> )	1.22E-3 (5.14E-5)	2.16E-3 (9.12E-5)	2.56E-3 (1.08E-4)

MODEL NUMBER	TG30	X	X	- X010	EXAMPLE: TG3053 - P010
Machine series	↑				
Rotor configuration		↑			
Winding configuration			↑		
Mounting option (M-Framed, P-Frameless Part Set)				↑	

<sup>1</sup> For more details including wiring options and operating parameters see the individual datasheets.