

Swivels up to 250 Kg

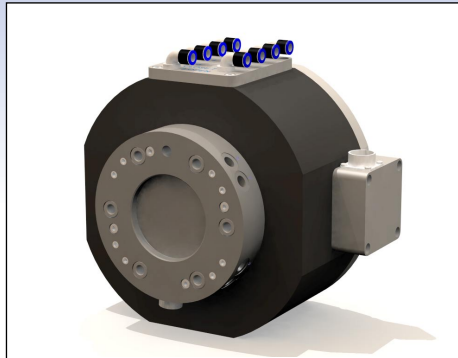

Swivels

The new generation of Swivels provide air supply and electrical signals without limiting your robots motion capabilities. You can spin the 6:th axis free from hoses, cables and other obstacles. The low weight, high corrosion resistance and minimum servicing will shorten your cycle-times, enhance your productivity and minimize downtime in any application involving substantial robot motions.

Advantages:

- No limitation of robot working space
- Fast and efficient retooling
- Minimum installation time
- Easier to reach tight positions due to fixed hosing and slim design

Technical data

Swivel	Part no.	Handling capacity (kg)	Electrical channels	Air channels	Weight (kg)	Max rpm	Max. moment (Nm)
S250-8	P6415	250	-	8	11.8	60	1790
S250-8E	P6416	250	18	8	12	60	1790

Electrical

Max voltage	60 V
Max current	2.0 A
Connections	19 socket Souriau

Air

Max air pressure	10 bar
Air flow	1600 l/min
Air quality	Oil-clean and waterless filtered air, max 25 µm particle content
Air connections	G 1/4"

Dimensional drawings

S250-8E:

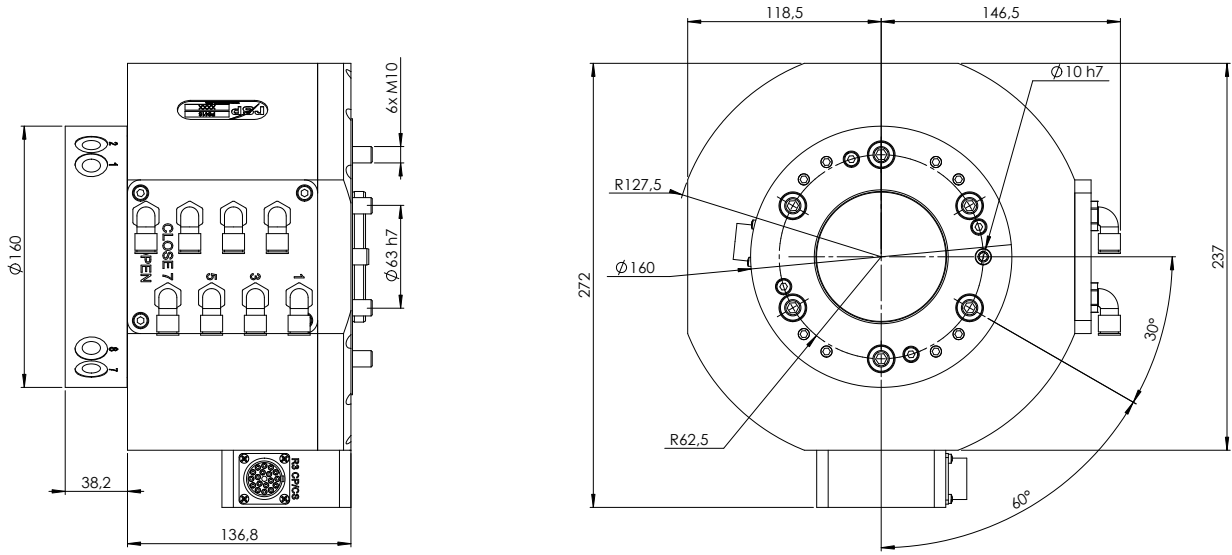

B0902-1 Mar 2007

Robot System Products offer complete, standardised media supply solutions for robot-based automation. We design, manufacture, and market a wide range of standard robot peripherals such as tool changers, swivels, hose packages, vacuum grippers and die-casting systems throughout the world.

Visit us at www.robotssystemproducts.com

