

Superior machine safeguarding and operator protection

F3SG-R Series Safety Light Curtains

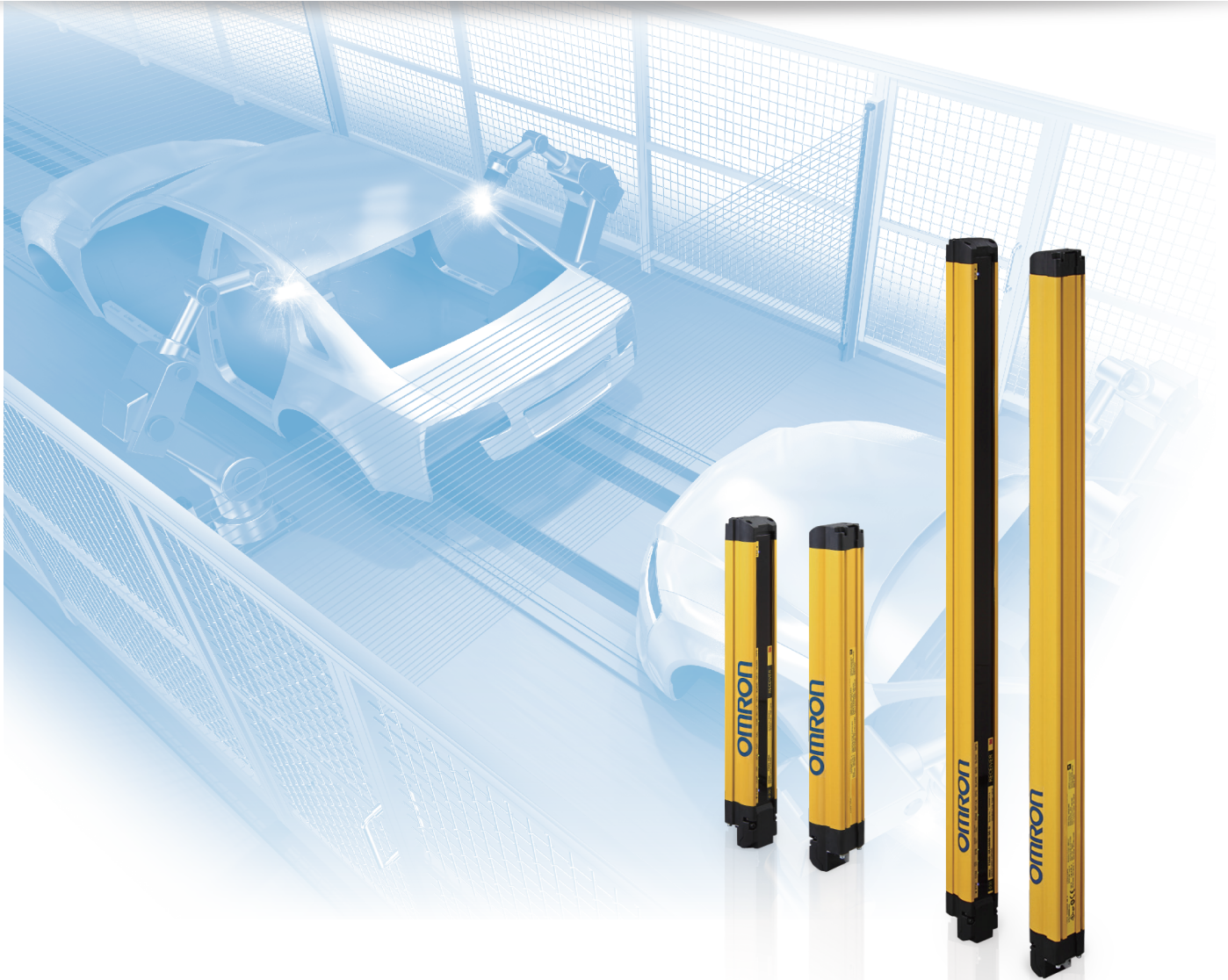

- Compact easy installation
- Robust even in severe environments
- Global reliable safety solutions

Next generation safety light

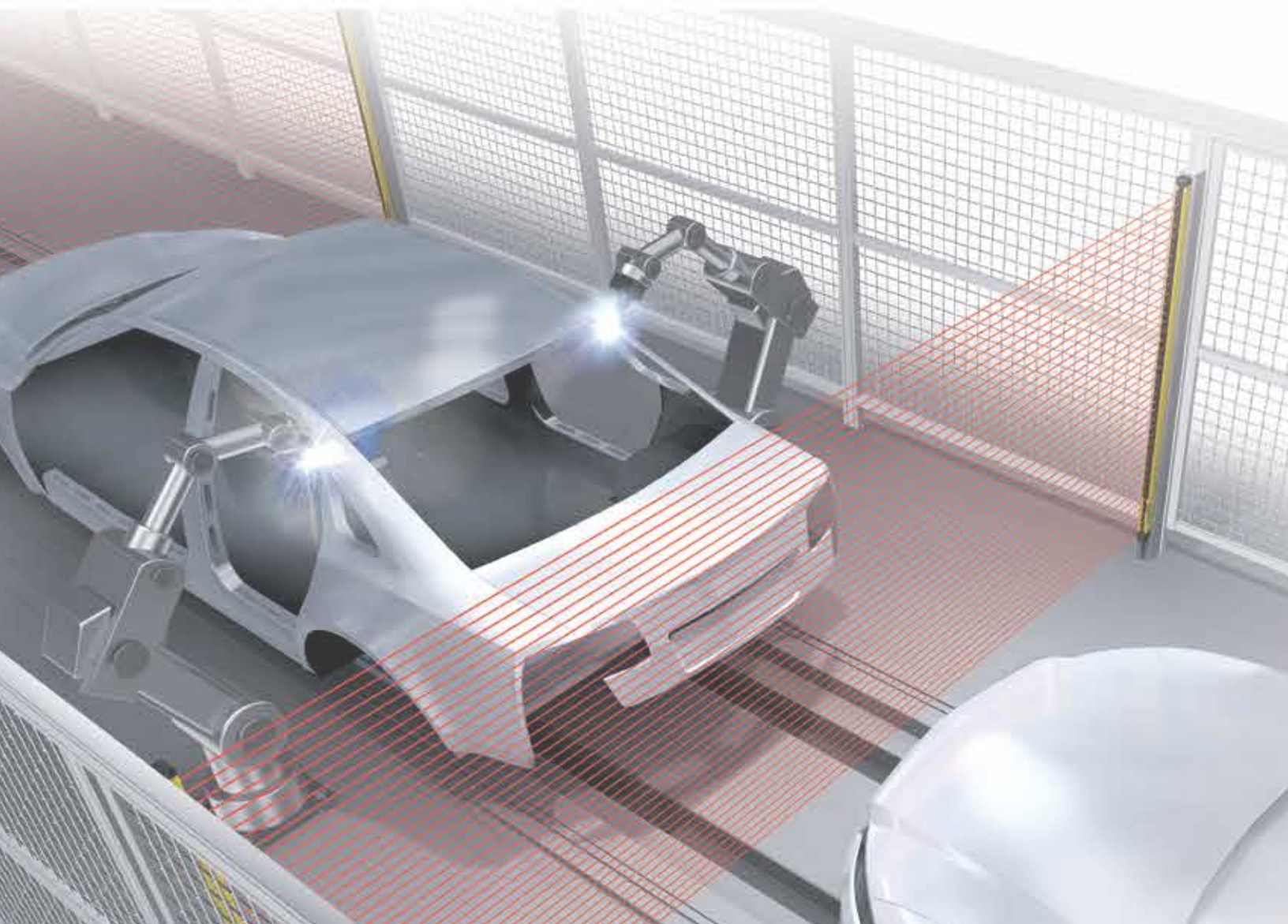

Advanced

Advanced type suitable for flexible production line applications

Economy

Economy type ideal for simple On/Off detection applications

NEW

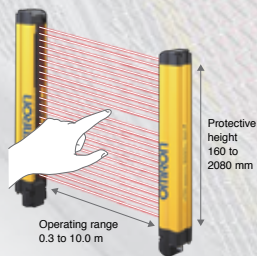

F3SG-4RA□□□□-14
Detection capability: Dia. 14 mm

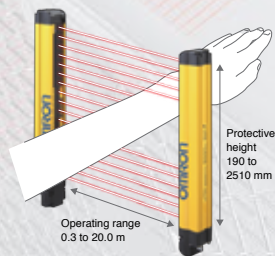

F3SG-4RA□□□□-30
Detection capability: Dia. 30 mm

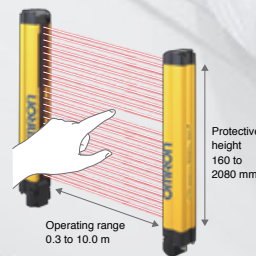

F3SG-4RE□□□□-14
Detection capability: Dia. 14 mm

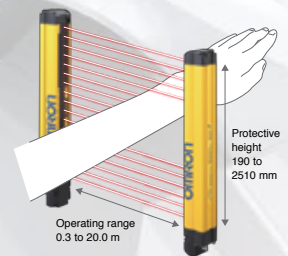

F3SG-4RE□□□□-30
Detection capability: Dia. 30 mm

curtain packed with powerful features, offering both robustness and reliability

F3SG-R Benefit

If just one single safety light curtain can be used in a variety of environments, the time required for selection, installation, and maintenance can be reduced.

Selection & Design

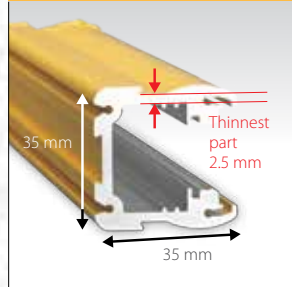

Easy Selection & Design

In almost any environment

Waterproof and shock-resistant yet compact body. Conforms to major international standards.

Ensuring safety in various production lines

The dynamic muting function automatically sets a minimum muting zone according to workpiece height. It can be used for a variety of production lines.

Complete safety measures by detecting presence

Distinguish between small objects and human entry by changing resolution and response time. This maintains a high level of safety while minimizing unexpected machine downtime.

Set-up

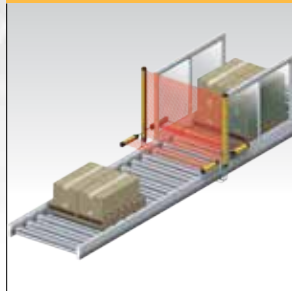

Easy Set-up

Drastically reduced set-up time and wiring

The Smartclick connectors and optical synchronization enable smooth set-up of machines.

Simple, two-step optical adjustment

Quick adjustment by checking beam alignment with the LED indicators and Configuration Tool SD Manager2.

Flexible installation

More flexible layout by eliminating the need of synchronization wiring and using extension cables.

Operation



Stable Operation

Quick troubleshooting and predictive maintenance

The sticker and error logs stored in the F3SG-R helps speed troubleshooting. Accumulated log data facilitates systematic maintenance.

Mutual interference prevention

The DIP switches are used to change emission light intensity to prevent mutual interference with other sensors.

Robustness

Allows use in a variety of environments

Protects itself and production sites

Robust and compact | Robust housing | Advanced Economy

All models are equipped with a robust housing that can be used in harsh conditions and withstand shocks caused by sudden human contact or a dropped tool. A scratch-resistant material is used for the optical surface preventing unexpected machine stops.

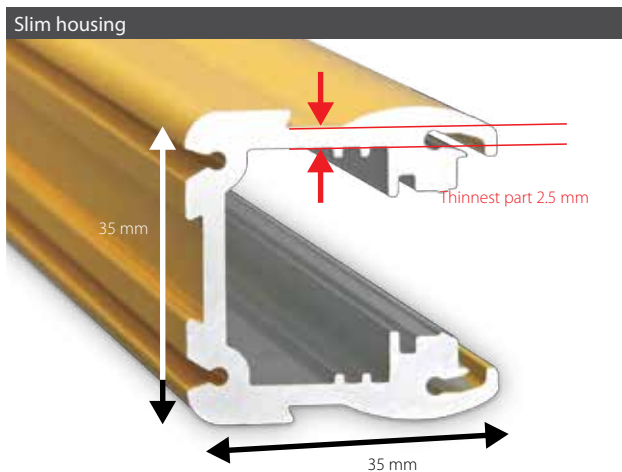

The housing structure is significantly improved to enhance resistance against shock and vibration and to reduce the thickness of the housing material from 3 mm to 2.5 mm.

Protection cover

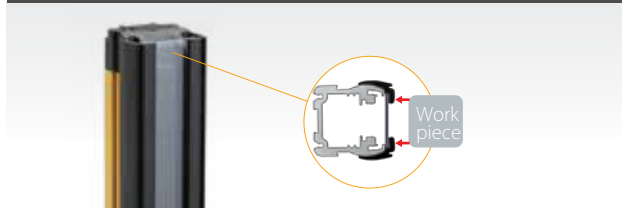

The optical surface can be protected from contact with workpieces by using the optional protection cover.

Downsized

The robust housing can be used in harsh conditions and withstand shocks caused by sudden human contact or a dropped tool. The scratch-resistant material is used for the optical surface to prevent unexpected machine stops.

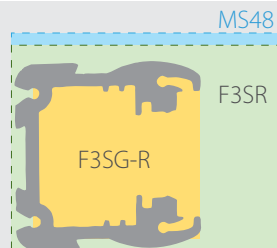

Cross-section is
Approx. **60%**
of previous model

In almost any environment | For global use |

The F3SG-R is designed to be used in a variety of environments around the world, conforming to international standards.

For global use

Advanced



PNP or NPN can be selected with the DIP switch. The same cables are used.



The F3SG-R conforms to major international standards.

For harsh environments

Advanced Economy

Secured against torsion

5
times more
torsion resistant*

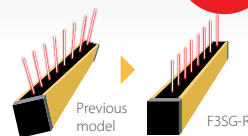

The risk of optical axis misalignment due to vibration or aging is greatly reduced.

*Compared to OMRON previous model in December 2014.



IP67 protection allows use in environments that are subject to water.

Reliable even in harsh environments

Advanced Economy

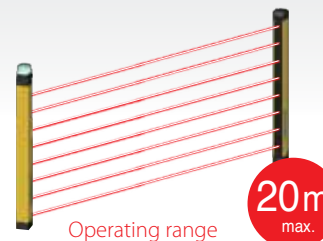

The newly designed high-power optical system provides best-in-class* light transmission and operating range. This allows stable operation even in dusty or other environments where light transmission is reduced.

*Based on OMRON investigation in December 2014.

New muting functionality

Increases both productivity and safety

Easily distinguishes between workers and objects

Increasing both productivity and safety

| Muting function | **Advanced**

The F3SG-R provides advanced muting function that detects the zone where workpieces pass or the position of a machine or robot and disable beams of the detected part. This increases both safety and productivity.

By adding the smart muting actuator, the F3SG-R provides stable operation even for the production lines where errors occur due to vibration caused by the passing workpiece.

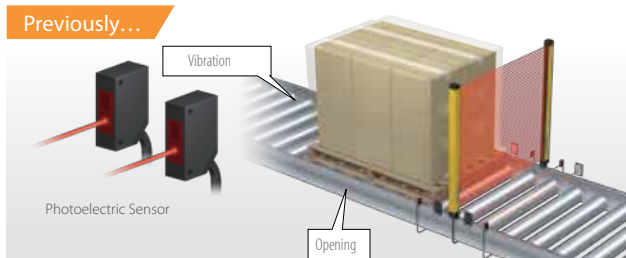

The point detection muting sensor mistakenly disabled muting while a workpiece was passing, which led to unexpected machine stops.

Smart muting actuator



The muting actuator detects the surface of a passing workpiece. Even if a workpiece moves due to vibration, muting is kept enabled until the workpiece has passed. This prevents unexpected machine stops.

Adjustment time reduced by 80%*

| Smart muting actuator |

The use of the dedicated actuator can significantly reduce the time required to adjust the sensor to detect workpieces even in unstable conveying conditions.

*Compared to the previous model
(Based on OMRON investigation in September 2014)



Previously... Many processes including programming and adjustment were required

Since bypass processing to disable the safety light curtain was performed via the PLC, programming before installation required time and work. It also took a lot of time and work to install and adjust many muting sensors (sensors and reflectors).

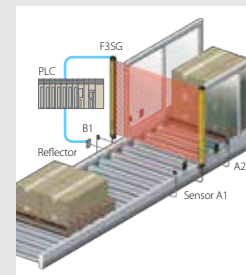

Powerful features

Prevent unexpected machine stops

Ensure stable operation

Auto-configuration of muting zone

| Dynamic Muting | **Advanced**

When workpieces with various heights are conveyed on the same line, partial muting is automatically performed based on the height of the workpiece. This advanced muting function can automatically perform normal detection at the zone where a workpiece does not pass.

Automatically minimizes muting zone according to workpiece size

1

When the muting sensor detects that a workpiece passes, all beams are muted.

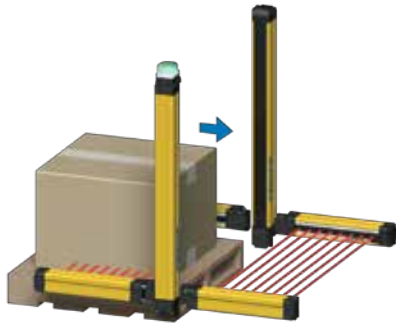

2

The only beams interrupted by the workpiece are kept muted and other beams are released from the muting state three seconds after the workpiece pass through the safety light curtain. Muting is disabled after the workpiece has passed.

Monitors human entry into the zone where a workpiece does not pass.

Keeps the zone muted when a workpiece passes.

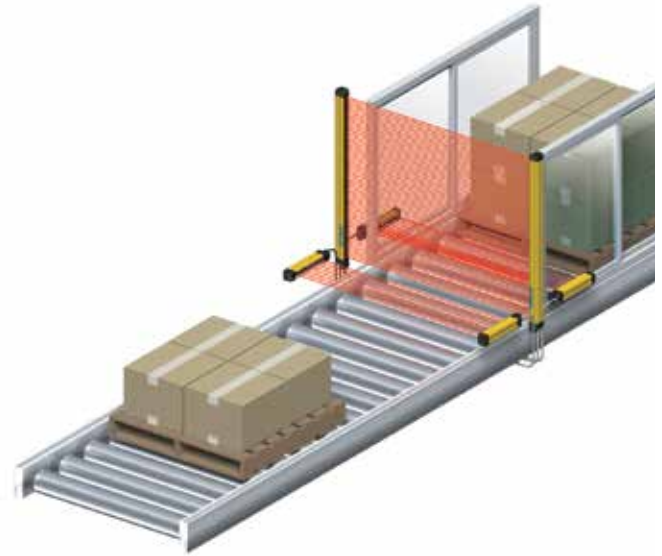
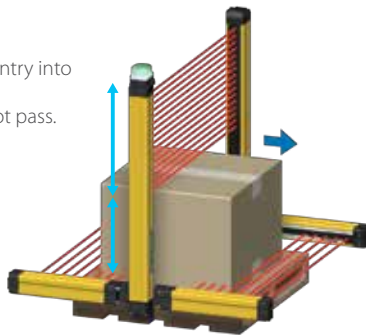

Minimizing setting and detection errors

| Configuration Tool SD Manager2 | **Advanced**

The function to log the muting sensor operating conditions of the F3SG-R visualizes the installation position and setting conditions of the sensor to achieve reliable configuration. The stop due to the muting error can be analyzed using the data stored in the F3SG-R. Quick identification of the cause can reduce unexpected machine downtime.

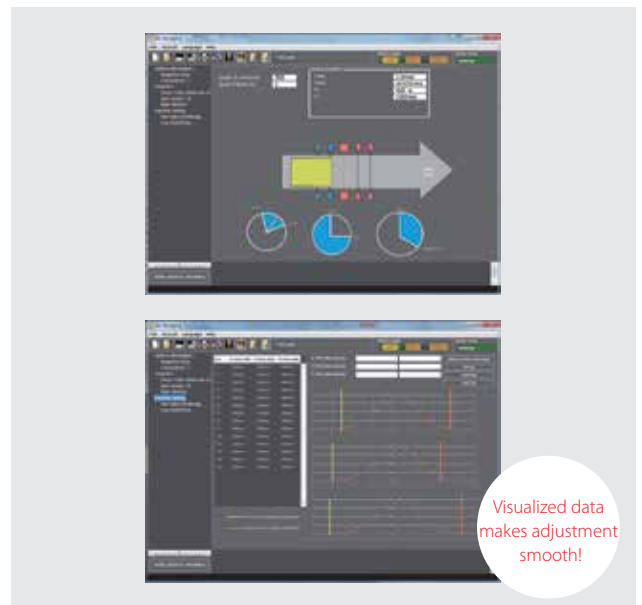

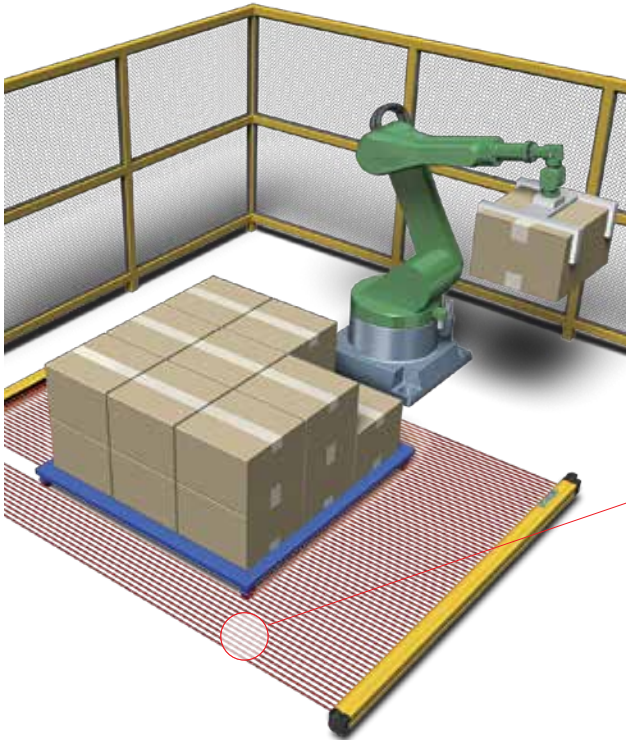

Detecting both objects and workers

| Reduced Resolution | **Advanced**

With the Reduced Resolution function that is used to change the number of interrupted beams (1 to 3 beams), the F3SG-R can detect human entry while workability is maintained. This makes it easier to distinguish between objects and workers.

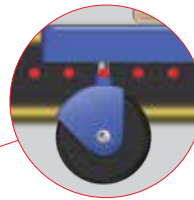

- Keep the safety outputs ON even when an object like a transport vehicle (with the size of 1 to 3 beams) is present intermittently.
- Turn safety outputs OFF when an object with the size over 3 beams, like an ankle.

Preventing accidental stops due to small debris

| Response Time Adjustment | **Advanced**

This function is used to distinguish between an instant passing of a small object such as an insect and a human passing by changing the time to respond to the block of the beam. Accidental machine stops can be avoided.

Ensuring safe restart

| Pre-reset | **Advanced**

The Pre-reset function prevents possible accidents and supports safe restart of machines. Even if a worker presses the reset switch of the safety light curtain without noticing another worker near the robot, restart will not be executed, unless certain conditions are met.

Helps prevent workers from being trapped

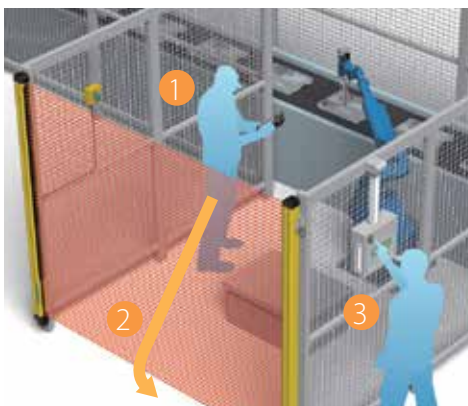

- 1 Press the pre-reset switch in the hazardous zone (safety fence)
- 2 Get out of the hazardous zone (safety fence)
- 3 Press the reset switch in the control panel to restart the F3SG-R. The machine is ready for restart.

The machine cannot be restarted until the pre-reset switch is pressed to restart the F3SG-R.

Smart

Wiring , beam adjustment, and operation check

Facilitate installation

No torque control required

| Smartclick | **Advanced** **Economy**

Smartclick connectors are used to quickly connect cables. Just turn the round waterproof M12 connector 1/8 of a turn. This stress-free connection reduces the time required for wiring and replacement when many devices are connected together.

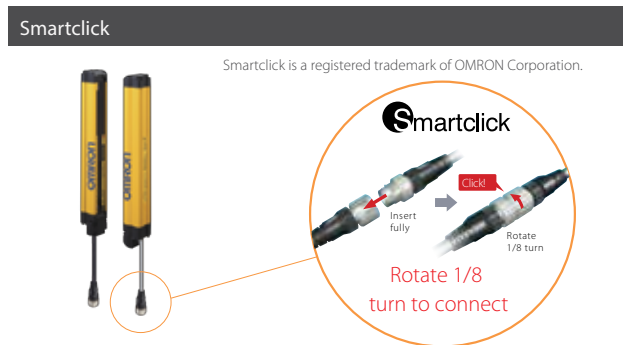

This popular connector is used for a variety of OMRON products to reduce time required for wiring and replacement when many devices are connected together.

Previously... Faulty connection and need of torque control

When many safety light curtains were connected, torque control of connectors was required and delay in set-up occurred due to failure of connection. The Smartclick connector can be connected with the existing screw-type M12 connector.

Long-distance wiring

| Maximum 100 m cable length | **Advanced** **Economy**

The total extension cable length is up to 100 m. Flexible wiring maximizes long-distance detection and optical synchronization functionality.

Simple wiring

| Simple wiring connector | **Advanced** **Economy**

Simple wiring connector can reduce wiring time. Fewer cables mean that the risk of disconnection and noise troubles can also be reduced.

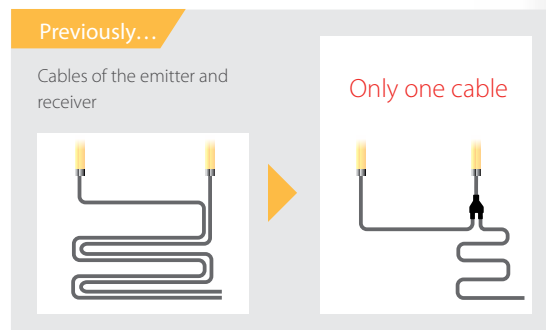

No limitation in wiring

| Optical synchronization | **Advanced** **Economy**

Optical synchronization eliminates the need of synchronization wiring between the emitter and receiver. Flexible wiring enables reducing disconnection risk and avoiding noise sources.

Flexible, new method

Fine tuning all beams, the F3SG-R provides high ambient light immunity and flexible detection functions.

High ambient light immunity

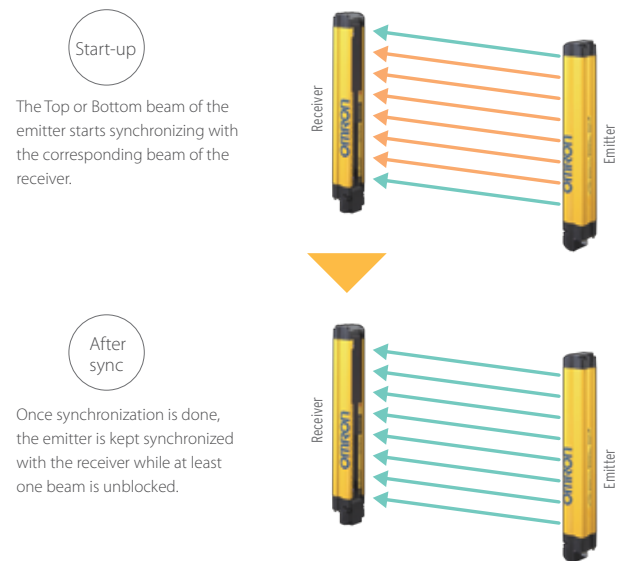

Previously... Limitations imposed by synchronization wiring

- Wiring between the emitter and receiver were required.
- With the previous synchronization function, if the Top or Bottom beam was blocked, synchronization was not maintained.

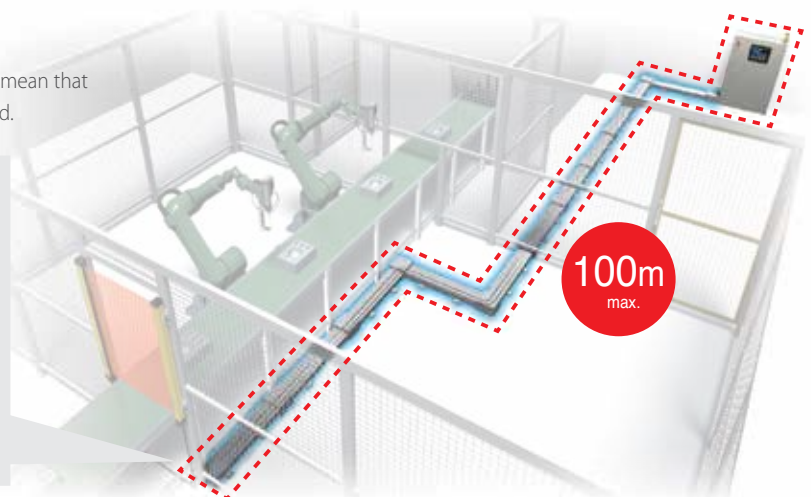

Simple two steps | Beam adjustment | Advanced

The benefit of robust, torsion-resistant housing contributes to reduce the time required to install the safety light curtain.

Simple adjustment: Coarse adjustment → positional alignment

Beam adjustment can be done easily by checking the TOP and BTM LED indicators. The SD Manager 2 helps install the safety light curtain by showing the incident light levels of each beam.

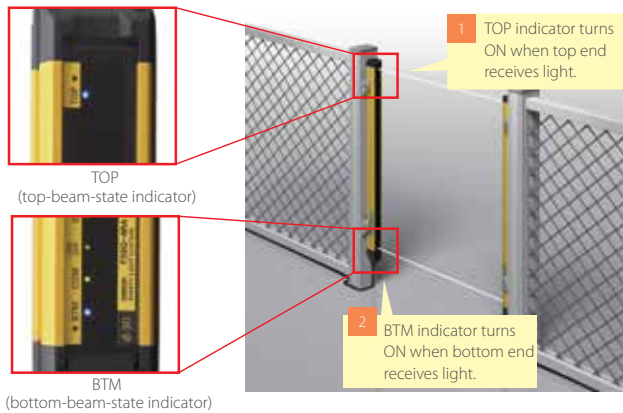

1 Adjustment is completed when the TOP, BTM, and STB LED indicators turn ON.



2 Finer adjustments can be made using the Configuration Tool SB Manager2.

Easy adjustment after mounting

| Mounting bracket | Advanced Economy

Two types of mounting brackets are available.

Standard fixed bracket
(Included)



Standard adjustable bracket
(sold separately)



After mounted on a safety fence, the F3SG-R can be slid vertically to adjust. This means this mounting bracket allows for a wider adjustment range than the existing top/bottom mounting bracket.

In addition to vertical adjustment, the angle can be adjusted up to $\pm 15^\circ$. adjusted up to $\pm 15^\circ$.



Standard fixed bracket

The bracket is included in the F3SG-R.

Protective height	No. of brackets included
Less than 1,280 mm	2 sets
1,280-2,270 mm	3 sets
2,350 mm or more	4 sets

Quick troubleshooting and predictive maintenance

Eliminate machine downtime to ensure stable operation

For global operators

| Multilingual troubleshooting | **Advanced** **Economy**

Troubleshooting in eight languages is published on the website to find causes and solutions of errors that occur during operation. Operators across the world can check the error details in their local languages, which will help them minimize time to troubleshoot.

Troubleshooting Web

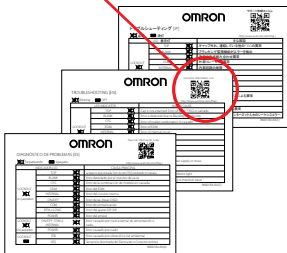

Troubleshooting guide sticker

* English, Chinese, Italian, Korean, French, German, Spanish, and Japanese



* The Interface Unit F39-GIF is required to connect with a personal computer.

Quick troubleshooting | Data logging 1 | **Advanced**

The error logs stored in the F3SG-R can be obtained by connecting with a personal computer via the interface unit. The Configuration Tool SD Manager2 analyzes error logs that helps to identify the cause of errors and suggest solutions. This helps simplify troubleshooting.

Reducing stops due to mutual interference

| Operating Range Selection | **Advanced** **Economy**

When other sensors are installed near the F3SG-R, Operating Range Selection helps reduce mutual interference.

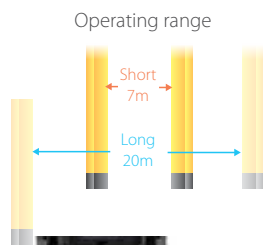

Mutual interference with the other sensor near the F3SG-R can be reduced by changing the mode from Long * to Short (7 m).

* Maximum operating range of 20 m for hand/arm protection or 10 m for finger protection.



The mode of Operating Range Selection can be selected with the DIP Switches on the emitter.

* For the F3SG-RE, the mode can be selected by wiring.

Systematic maintenance based on trend management

| Data logging 2 | **Advanced**

By using the Configuration Tool SD Manager2, the data of light intensity, power-ON time, and switching frequency of the F3SG-R can be collected regularly to predict when systematic and preventive maintenance is required.

Easy-to-use safety sensor

Ideal for simple on/off detection applications



NEW Economy

Robust but slim housing and basic safety functions are inherited from the F3SG-R Advance type. Providing only simple safety functions, the Economy type helps save TCO (Total Cost of Ownership) by reducing errors that require a lot of time to identify the causes.

Simple wiring

Only four wires are required for the minimum configuration, which is as simple as wiring a photoelectric sensor. Simple connection with a safety controller makes it easy to build a safety circuit. Commercially available M12 connector cables can be used for extension cables.

Fast response time of 5 ms

The Economy type that allows the distance between the light curtain and hazard source to be reduced is best suited to use in a small machine.

F3SG-R Line-up

For flexible production lines

Advanced type F3SG-RA

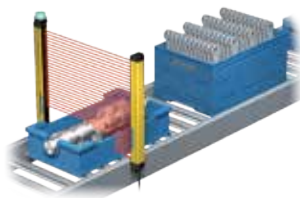

Economy type F3SG-RE



For small machines

List of Feature

Feature	Advanced type	Economy type	Factory default setting
	F3SG-RA	F3SG-RE	
PNP/NPN Selection	<input checked="" type="checkbox"/>		PNP output
External Test	<input checked="" type="checkbox"/>		24 V Active
Interlock	<input checked="" type="checkbox"/> <input type="checkbox"/>		Auto Reset Mode
Pre-Reset	<input checked="" type="checkbox"/> <input type="checkbox"/>		Disabled
External Device Monitoring(EDM)	<input checked="" type="checkbox"/> <input type="checkbox"/>		Disabled
Auxiliary Output		<input type="checkbox"/>	Muting /Override information
Muting		<input type="checkbox"/>	Standard Muting mode
Override		<input type="checkbox"/>	Enabled
Fixed Blanking	<input checked="" type="checkbox"/> <input type="checkbox"/>		Disabled
Floating Blanking	<input checked="" type="checkbox"/> <input type="checkbox"/>		Disabled
Reduced Resolution		<input type="checkbox"/>	Disabled
Warning Zone		<input type="checkbox"/>	Disabled
Scan Code Selection	<input checked="" type="checkbox"/>		CodeA (F3SG-RA only)
Operating Range Selection	<input checked="" type="checkbox"/>	<input checked="" type="checkbox"/>	Short mode
Response Time Adjustment		<input type="checkbox"/>	Standard mode
Lamp		<input type="checkbox"/>	Red:Disabled Orange:Disabled Green:Muting/Override information
Designated Beam Output		<input type="checkbox"/>	Disabled

Setting by DIP Switch Setting by Configuration Tool Setting by Wiring

OMRON AUTOMATION AMERICAS HEADQUARTERS • Chicago, IL USA • 847.843.7900 • 800.556.6766 • www.omron247.com

OMRON CANADA, INC. • HEAD OFFICE

Toronto, ON, Canada • 416.286.6465 • 866.986.6766 • www.omron247.com

OMRON ELECTRONICS DE MEXICO • HEAD OFFICE

México DF • 52.55.59.01.43.00 • 01-800-226-6766 • mela@omron.com

OMRON ELECTRONICS DE MEXICO • SALES OFFICE

Apodaca, N.L. • 52.81.11.56.99.20 • 01-800-226-6766 • mela@omron.com

OMRON ELETRÔNICA DO BRASIL LTDA • HEAD OFFICE

São Paulo, SP, Brasil • 55.11.2101.6300 • www.omron.com.br

OMRON ARGENTINA • SALES OFFICE

Cono Sur • 54.11.4783.5300

OMRON CHILE • SALES OFFICE

Santiago • 56.9.9917.3920

OTHER OMRON LATIN AMERICA SALES

54.11.4783.5300

OMRON EUROPE B.V. • Wegalaan 67-69, NL-2132 JD, Hoofddorp, The Netherlands. • +31 (0) 23 568 13 00 • www.industrial.omron.eu

Authorized Distributor:

Automation Control Systems

- Machine Automation Controllers (MAC) • Programmable Controllers (PLC)
- Operator interfaces (HMI) • Distributed I/O • Software

Drives & Motion Controls

- Servo & AC Drives • Motion Controllers & Encoders

Temperature & Process Controllers

- Single and Multi-loop Controllers

Sensors & Vision

- Proximity Sensors • Photoelectric Sensors • Fiber-Optic Sensors
- Amplified Photomicrosensors • Measurement Sensors
- Ultrasonic Sensors • Vision Sensors

Industrial Components

- RFID/Code Readers • Relays • Pushbuttons & Indicators
- Limit and Basic Switches • Timers • Counters • Metering Devices
- Power Supplies

Safety

- Laser Scanners • Safety Mats • Edges and Bumpers • Programmable Safety Controllers • Light Curtains • Safety Relays • Safety Interlock Switches