

Programmable Controllers
SYSMAC

OMRON
AUTOMATION & SAFETY

CJ2 FAMILY

PLCs with a proven track record



» Flexibility in communication

» **Faster machine development**

» Innovation through evolution

Innovation without growing pains

As a modern machine manufacturer you need to continuously increase the intelligence and flexibility of your product to remain competitive. But you also need to be absolutely certain that it all works perfectly, first time, every time.

The CJ2 is the result of years of experience as a market leader in the field of modular controllers and represents a logical next step in controller design. It offers greater performance and faster I/O response as well as extreme scalability - so you will only need one family. In addition, programming, debugging and networking are faster and easier. Welcome to the new CJ2 Family: built to give you innovation without growing pains.

The CJ2 can directly replace any previous generation CJ1 CPU with the following additional significant advantages:

Open to the world - High speed EtherNet/IP

Many CJ2 models offer a built-in multifunction EtherNet/IP port for high speed data exchange between PACs, PLCs, HMIs and I/O devices. In addition to the hundreds of third party suppliers, the CJ2 easily connects to Rockwell's ControlLogix, CompactLogix and MicroLogix controllers. EtherNet/IP is the most requested industrial Ethernet network in North America and it gives users powerful connectivity without the expense of adding extra hardware.

Advanced motion control

CJ2 units offer multi-axes synchronous control, and can replace expensive motion controllers.

Tag programming

Models with built-in EtherNet/IP use a common tag database between the controller and HMI that can reduce development time, allowing your products to get to market faster.

Scalable architecture

The CJ2 platform allows you to pick and choose the CPU & I/O based on your needs. This gives the user a common platform whether the machine has 16 I/O or 5000 I/O making stocking hardware simple and cost effective and reducing the training **necessary**



because the set up is the same throughout the CJ2 family.

One software

CX-One incorporates all the tools to program, monitor & troubleshoot your entire machine. This will save valuable time in installation, training, update and maintenance of individual software packages.

Simplicity

Reduce setup time as modules easily connect & lock together allowing the user to simply attach power, plug in a standard USB programming cable and begin programming. The CJ2 is about 1/2 to 1/3 the size of many other PACs & PLCs in the market allowing smaller panel sizes which saves money and produces a smaller footprint. Omron supports a single connection to monitor and program all devices located locally or networked. Remote troubleshooting over a modem or Internet can save thousands of dollars on travel & expenses and increase machine uptime.



The wide range of CPUs means you need only to get familiar with one PLC family for use in everything from simple stand-alone applications up to networked, high-speed machines.

Inspired by proven technology



Proved track record

The CJ2 Family is based on the highly popular CJ1, which after its launch in 2001 is operating in an extraordinary variety of applications all over the world. Now, as the natural successor, the CJ2 combines that field-proven technology with a wider choice of CPUs, more speed and memory, and a wider variety of communication interfaces.



Faster development

Tag-based communications technology will simplify the interfacing of the PLC to the outside world. On-line debugging improvements also help to accelerate software development so you can change the code and test the results quickly. The added function block memory will allow you improve to program structure and reuse of code even in the entry-level models.

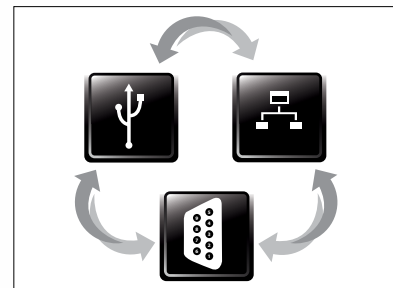

Talks to all

The CJ2 Family supports major open networking technologies including:

- Ethernet-based communication based on open industrial standards
- Serial communications over RS-232 C, RS-422, RS-485 and USB
- The major open Fieldbus standards
- Fast and accurate motion control networks.



Built to answer your needs

Omron has used its experience as a specialist machine automation supplier to develop the CJ2. The result is an extremely reliable controller that is also a powerful example of our commitment to continuous improvement. The CJ2 Family is a major opportunity to innovate and simultaneously reduce cost now and in the future.

It's the obvious choice for modern machine builders.



Power supply

Pulse I/O

CPUs

Wide range CPU capacity

To stay ahead in the machine-building business, you need to grow with your end-user's needs. Faster production, better quality control and better traceability require more speed and more memory. That's why the CJ2 Family offers a wide range of CPUs- to suit any task. From 5 Ksteps program capacity and 64 Kwords memory, right up to 500 Ksteps capacity and 832 Kwords.

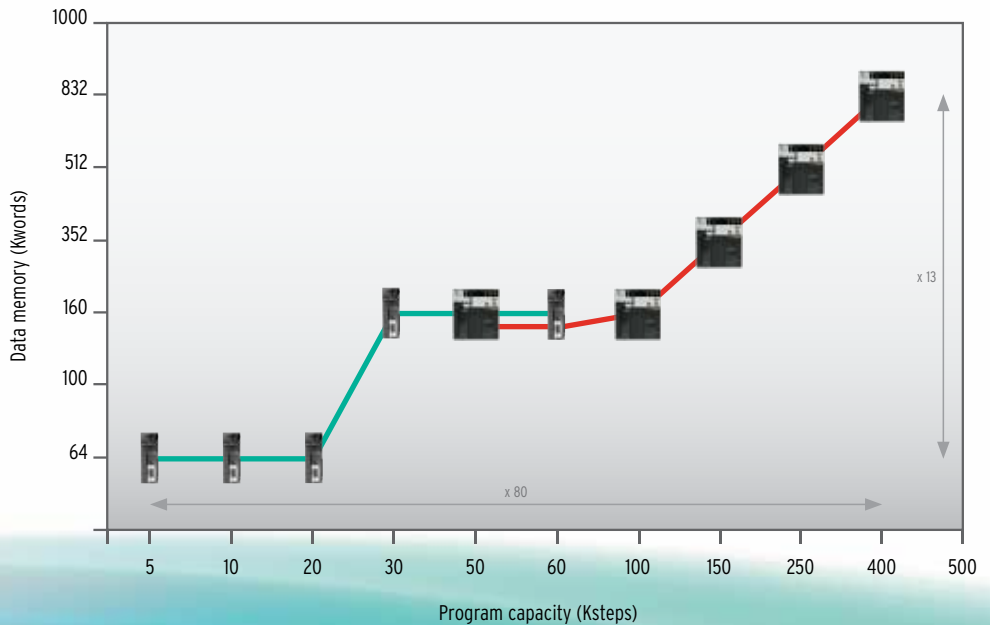
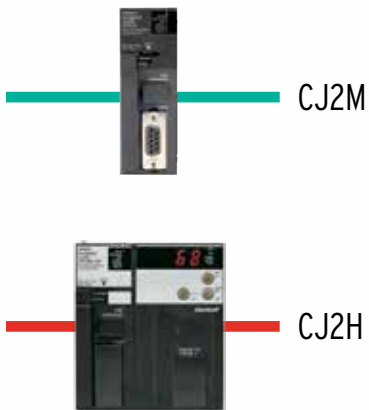



Communication

Motion

Analog I/O

Digital I/O

Higher precision

In addition to the greater CPU processing performance, Omron has also added new high-speed I/O units, such as analog input units with 20 μs conversion time, while new PLC instructions provide immediate access to fast I/O data. The result is even more real-time reliability.

Select what you need

With CJ2 you can also still connect to the existing CJ1 I/O units. You can benefit from CJ2's improvements without redesigning the entire system.

Easy connection by USB

Simply connect the cable, with no settings required

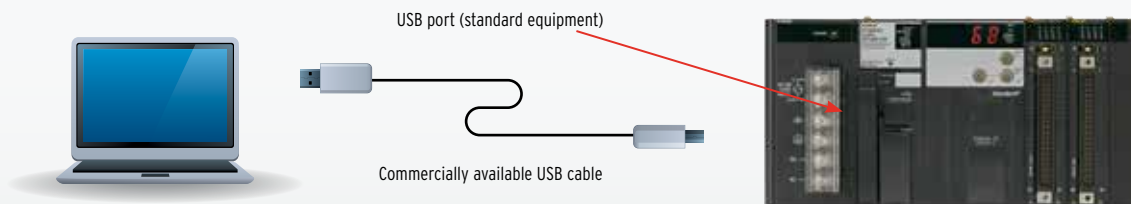

A CJ2 CPU Unit on an EtherNet/IP network can be accessed via USB, with no need for routing tables

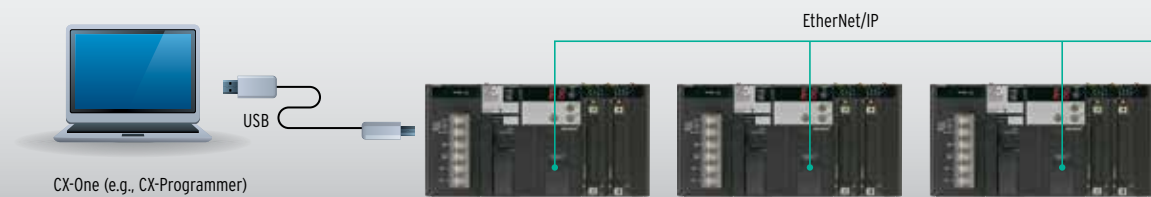

One family - Two performance classes

CJ2M for standard machine automation

The CJ2M Series is ideal for packaging and general machine automation needs. Connectivity is assured thanks to the built-in USB port and the choice of Ethernet and RS-232C/422/485 interfaces on the CPU.

Key Features

- Easy & Fast Connection: USB Programming Port
- Program Capacity : 5K Steps - 60K Steps
- Data Storage: 64K Words - 160K Words
- Dedicated Function Block Memory - 20K Steps
- Symbol, Comment Memory - 1MB

- Always accessible through standard USB port
- Standard Ethernet port with EtherNet/IP Data Link function
- Wide range of program capacities, from 5 Ksteps to 60 Ksteps
- Pulse I/O add-on modules have a special connection to the CPU and are controlled by convenient positioning instructions
- Serial option board for CJ2M-CPU3*
- Dedicated function block memory ensures efficient execution of function block software modules

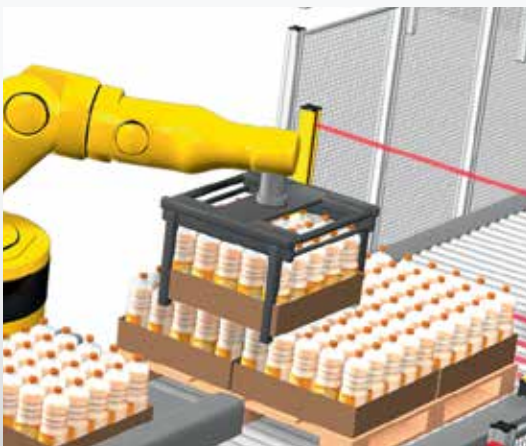

Pulse I/O modules

By mounting optional pulse I/O modules, you can extend the functionality of any CJ2M CPU with:

- interrupt inputs
- quick-response inputs
- high-speed counters
- incremental encoder inputs
- pulse frequency control outputs
- pulse width control outputs

Up to two modules can be mounted per CPU, allowing direct control of four motion axes. Using dedicated instructions, these axes can be controlled directly by the PLC program, without communication delays.

* Supported by the CJ2M CPU Unit with version 2.0 or higher.

CJ2H for ultra high speed capacity

The CJ2H Series is ideal for advanced machine automation needs such as those required in image processing inspection of electrical components and high speed sorting on conveyors.

Key Features

- Easy & Fast Connection: USB Programming Port
- Program Capacity : 50K Steps - 400K Steps
- Data Storage: 160K Words - 832K Words
- Symbol, Comment Memory - 3.5MB

Advanced motion control - made simple

The CJ2H's advanced motion control avoids the use of expensive motion controllers. Synchronized control is possible on up to 20 axes by using just five Position Control units (High-speed type). And, programming is easy - simply paste an electronic cam function block into a synchronized interrupt task.



- Always accessible through standard USB port
- Standard Ethernet port with EtherNet/IP Data Link function
- High program capacity of up to 400K Steps
- Higher precision for machine operation and processing quality
- Immediate refreshing of basic I/O ensures real-time processing
Faster response means higher precision and better quality
- High data memory capacity of up to 832 Kwords

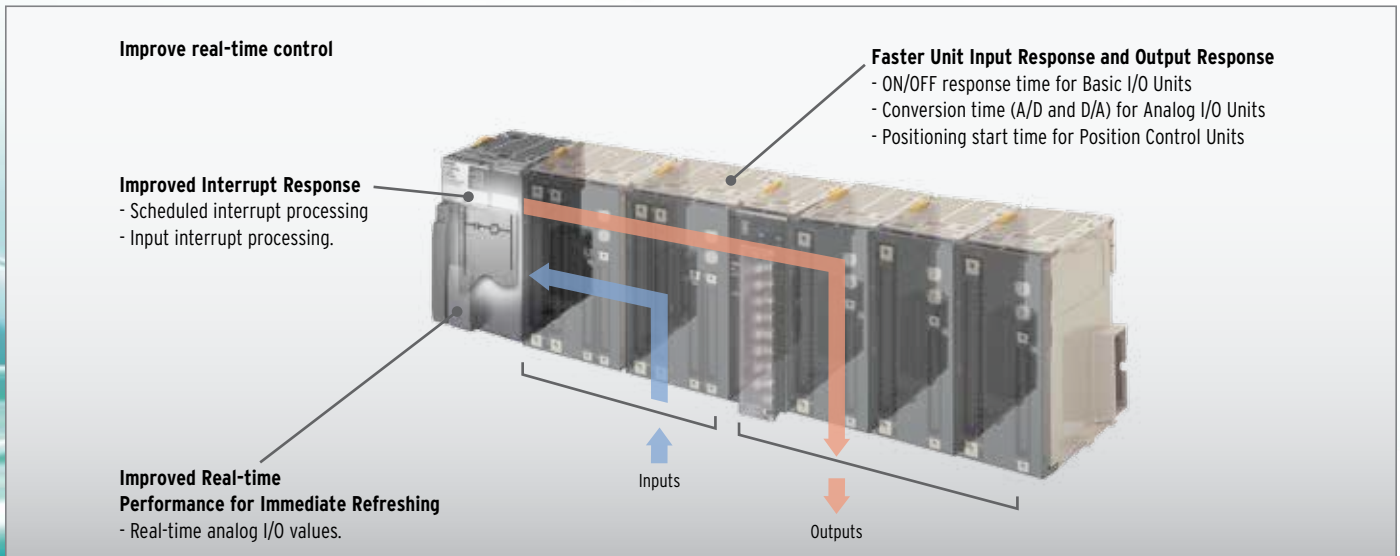

Lineup

The CJ2 Provides a Complete Lineup

The complete lineup provides high-performance features from machine control to information processing.

Units		CJ2M		CJ2H	
Type		Simple Types	Standard Types	High - end Types	Flagship Types
Models		CJ2M-CPU1□	CJ2M-CPU3□	CJ2H-CPU6□	CJ2H-CPU6□-EIP
Appearance					
Dimensions (W x H x D mm)		31 x 65 x 80	62 x 65 x 80	49 x 65 x 80	90 x 65 x 80
Program Capacity		Up to 60 Ksteps		Up to 400 Ksteps	
Data Memory Capacity		Up to 160 Kwords		Up to 832 Kwords	
I/O Bits		2,560			
Basic Instructions(LD)		40ns		16ns	
Special instruction (MOV)		120ns		48ns	
Floating-point decimal instructions (SIN)		0.86μs		0.59μs	
System overhead time		160μs	270μs	100μs	200μs
FB Program Area		YES (Equivalent to 20K steps.)		—	
Communications Port	USB Port	YES			
	Option Port	YES (RS-232C)	One Option Board Modbus TCP Slave (RS-232C or RS-422A/485)	YES (RS-232C)	
	EtherNet/IP Port	—	YES	—	YES
Serial PLC Links		YES	YES (A Serial Option Board is required)	—	
High-speed Interrupt Function		—		YES	
Synchronous Unit Operation		—		YES (In combination with a CJ1W-NC□□4 Position Control Unit)	
Pulse I/O Modules*		YES (Up to two Pulse I/O Modules can be mounted)		—	

*A Pulse I/O Module must be mounted for CJ2M CPU Units with unit version 2.0 or higher.

Improve Basic Performance

The Pursuit of High-speed Performance as a Controller

CJ2H

All processes that affect the cycle time have been made faster.

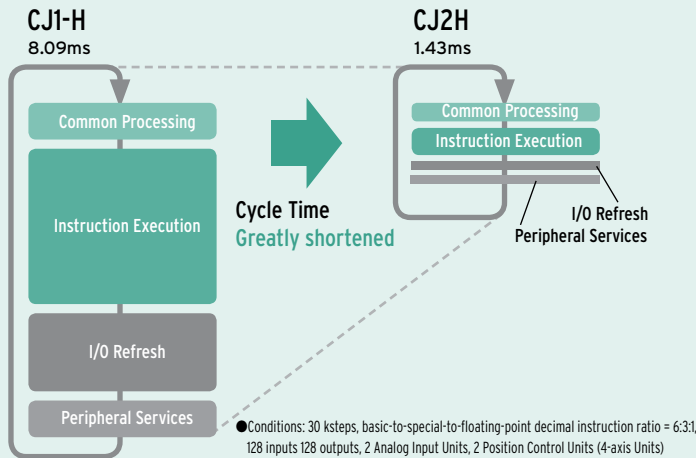

- Common Processing **300μs** ▶ **100μs** 3 times faster
- Instruction Execution LD **20ns** ▶ **16ns** 1.2 times faster
 SIN **42μs** ▶ **0.59μs** 71 times faster
- Refresh
- Basic I/O Unit: **3μs** ▶ **1.4μs** 2 times faster
- Immediate refreshing **20μs** ▶ **1μs** 20 times faster
- Interrupt Response
- Minimum Interval for Scheduled Interrupts **200μs** ▶ **100μs** 2 times faster
- Interrupt Response Time for Input Interrupts **30μs** ▶ **17μs** 1.8 times faster

Ample Instruction Execution Performance for Machine Control.

The CJ2 Series fully responds to customer requests for improved tact time and increased information.

System Overhead

- Common processing ▶ **100μs***
- Interrupt response ▶ **30μs**

Basic instructions

- LD instruction execution ▶ **16ns**
- OUT instruction execution ▶ **16ns**

Floating-point decimal instructions

- SIN calculation ▶ **0.59μs**
- Floating-point decimal addition and subtraction ▶ **0.24μs**

*CJ2H-CPU6□-EIP:200μs

Faster Immediate I/O Refreshing

Realtime I/O during Instruction Execution

Immediate refreshing(!!LD) ▶ **1 μs**

20 Times Faster

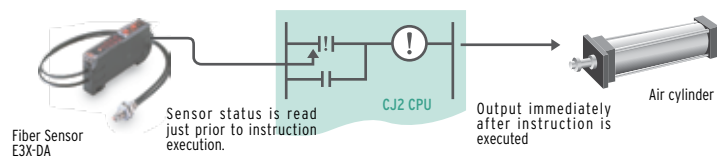

Improved Interrupt Response

For Finer Control

Faster Interrupt Response Time for Input Interrupts

[Immediate Execution at a Sensor Input]

Interrupt Response Time for Input Interrupts ▶ **17 μs***

1.8 Times Faster



CJ2H CPU Unit with unit version 1.1 or later is used.

Shorter Minimum Interval for Scheduled Interrupts

[Ideal for Processing at a Fixed Interval]

Minimum Interval for Scheduled Interrupts ▶ **100 μs*1**

2 Times Faster
Fastest in the Industry*2



CJ2H CPU Unit with unit version 1.1 or later is used.

* With the High-speed Interrupt Function

*1 Supported only for one scheduled interrupt task. The peripheral (USB) port or serial port of the CPU Unit can not be used at the same time.

*2 According to February 2010 OMRON survey in Japan.

Pulse I/O Modules

Pulse I/O Modules expand the applicable positioning applications

CJ2M

Easily execute the position control of up to four axes

Either one or two Pulse I/O Modules can be connected to a CJ2M CPU Unit. The programming is as easy as pasting OMRON Function Blocks for positioning, or special instructions.

Pulse I/O Functions (for Two Pulse I/O Modules)

Input interrupts	8 points
High-speed counter inputs:	Single-phase, 100 kHz, 4 CHs or Phase-different input, 50 kHz, 4 CHs
Pulse outputs:	100 kHz, 4 axes or four PWM outputs

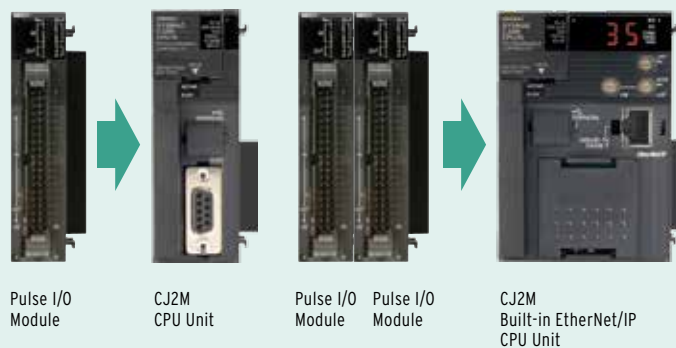

Note. A Pulse I/O Module must be mounted for CJ2M CPU Units with unit version 2.0 or higher.

Input Interrupts

Up to eight interrupt inputs or quick-response inputs can be used.

- Pulse width as short as 30μs can be input with quick-response inputs.
- High-speed processing and interrupt response time of 33μs (in Direct Mode).
- Interrupts can be created for both of rising and falling edges.

High-speed Counters

Up to four high-speed counter inputs can be used by connecting rotary encoders to Pulse inputs.

- High-speed counting at 100 kHz for single-phase and 50 kHz for phase-different input.

High-speed Counter in Linear Mode

For applications such as conveyors.

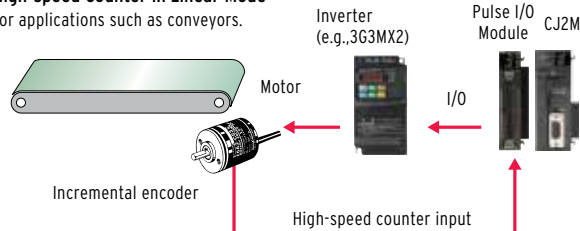

High-speed Counter in Ring Mode

For applications such as electronic component index tables.

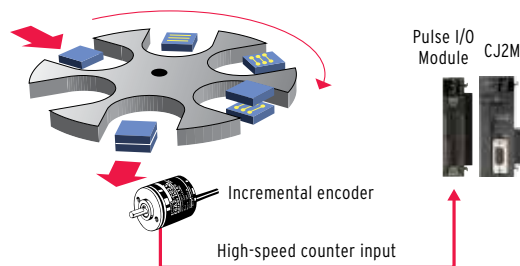

- The ring counter maximum value of a high-speed counter can be changed temporarily during operation.
- Start Interrupt Tasks using Target Value Comparison or Range Comparison for high-speed processing.
- The frequency (speed) can be easily measured by executing HIGH-SPEED COUNTER PV READ (PRV(881)) instruction.
- Ideal for applications such as measuring the speed of rotating bodies for inspections or detecting conveyor speeds.
- Can also be used for monitoring accumulated motor rotations.

Pulse Outputs

From stepping motors to servos, positioning control can be easily achieved using pulse outputs for up to four axes.

Faster and easier

- Pulse control cycle of 1 ms (1/4 of OMRON's CJ1M). Achieve smoother acceleration and deceleration.
- Faster starting of position control (twice as fast as OMRON's CJ1M). Helps reduce machine takt time.
- INTERRUPT FEED instruction (IFEED(892)). Execute high-precision feeding from interrupt inputs with just one instruction.
- Close integration with the data trace function of the CX-Programmer for easy monitoring of positioning operations.

Complete positioning functions

Positioning control variations	Operation patterns	Application examples	Special instructions, OMRON Function Blocks
<p>Trapezoidal Acceleration/Deceleration Positioning</p> <p>Acceleration/deceleration time can be shortened with Trapezoidal Acceleration/Deceleration Positioning function and Triangular are provided for reducing out-of-step operation for stepping motors and eliminating error downtime.</p>	<p>• Basic Form</p> <p>• Setting Acceleration and Deceleration Separately</p> <p>• S-curve Acceleration/Deceleration Setting</p> <p>• Triangular Control</p>	<p>PCB Conveyor Rail Width Positioning</p>	<p>Achieved with a single OMRON Function Blocks for specifying absolute (or relative) travel.</p>
<p>Changing the Target Position during Positioning</p> <p>The target position can be changed during positioning. It is also possible to reverse direction when changing the target position.</p>	<p>Travel start, Target position (frequency, acceleration/ deceleration) changed</p>	<p>Position Control Using Data Measured after Startup</p>	<p>While position control is being executed by a PLS2 instruction, another PLS2 instruction can be used to override the first PLS2 instruction.</p> <p>• Starting Trapezoidal Control</p> <p>• Changing the Target Position with Another Instruction</p>
<p>Interrupt Feeding</p> <p>It is possible to change to positioning control during speed control. Interrupt feeding can be executed after the interrupt for a specified number of pulses. Setting and starting interrupt feeding is possible with one instruction without using an interrupt task.</p>	<p>Speed control (FEED instruction)</p> <p>A specified number of pulses are output and then positioning stops.</p> <p>Travel start</p>	<p>High-precision Interrupt for Positioning</p> <p>Sheet feeding direction</p> <p>Constant sheet length from detection of mark until heat welding.</p>	<p>Achieved with a single OMRON Function Block for interrupt feeding.</p>
<p>Sequential Positioning</p> <p>Travel to multiple preset points can be executed. This is effective for applications such as positioning loaders and unloaders at multiple points.</p>		<p>PCB Rack Positioning</p>	<p>Achieved with a single OMRON Function Block for specifying sequential positioning.</p>

Improved System Throughput

Flexible Machine Control with Refined I/O Performance

CJ2H

CJ2M

Improve realtime control.

Improved Realtime Performance for Immediate Refreshing

Direct Processing with analog I/O

Faster Unit Input Response and Output Response

Basic I/O Units, Position Control Units, Analog I/O Units, Serial Communication Units

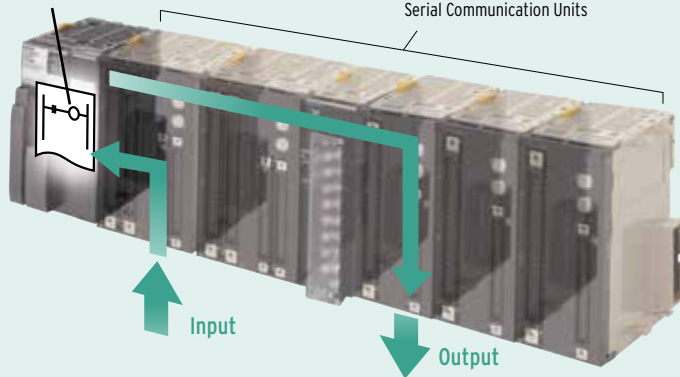

In addition to the greater processing performance of the CPU Unit, OMRON has also improved the response performance of each Unit. Faster throughput from inputs and processing to outputs helps to improve equipment tact time and work processing quality.

Faster Unit I/O Response

Lineup of High-speed Units

Faster ON/OFF response time

[Improved Basic Response]

- ON response time ▶ 15 μ s 1.3 Times Faster
- OFF response time ▶ 90 μ s 4 Times Faster



Basic I/O Units:
High-speed type
CJ1W-ID212
ID233

High-speed Positioning

[High-speed All the Way to Pulse Output]

- Positioning start time ▶ 0.1 ms* 20 Times Faster



Position Control Units:
High-speed type
CJ1W-NC□□4

* Starting time for first axis when all axes are stopped.

High-speed Analog I/O

[Improved Basic Response]

- A/D, D/A conversion period ▶ 20 μ s / 1 point
~ to 35 μ s / 4 point



Analog Input/
Output Unit:
High-speed type
CJ1W-AD042
CJ1W-DA042V

* According to February 2010 OMRON survey in Japan.

12 Times Faster Fastest in the Industry

High-speed Serial Communications (No-protocol)

[Data Reception in Microseconds]

- Consistent high speed is achieved from data reception to storage in CPU Unit memory. ▶ 210 μ s* 162 Times Faster
- Continuous reception is possible on a high-speed cycle. ▶ 800 μ s* 42 Times Faster
- Baud rate ▶ 230 kbps



Serial Communication Unit:
High-speed type
CJ1W-SCU□2

* CJ2H CPU Unit with unit version 1.1 or later is used.
230kbps,10bytes,The DRXDU instruction is used in an interrupt task.

You Get Both the Easy Startup of Networks and the High-speed Starting of Pulse-train Control

Up to 16 axes

CJ2M CJ2H

Highest Class Performance in the Industry for Faster, More-precise Systems with Less Wiring

High-speed starting and control performance equivalent to those of pulse-train systems are achieved through network connections.

- Starting time ▶ 0.4ms* 5 Times Faster
- Communications performance ▶ 100Mbps 10 Times Faster
- Control cycle ▶ 0.5ms 4 Times Faster

EtherCAT

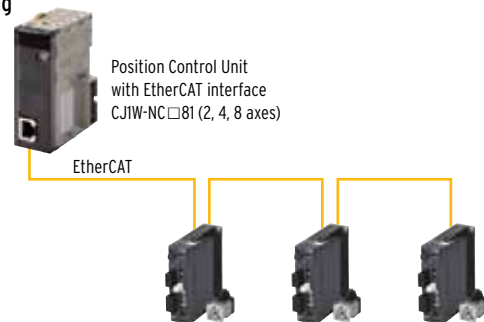

OMNUC G5-series Servo Drives with Built-in EtherCAT Communications

* A CJ2H CPU Unit with unit version 1.3 or higher or a CJ2M CPU Unit is required.

Built-in EtherNet/IP Port

EtherNet/IP Is User Friendly in Three Ways

An open industrial network that implements a control protocol on general-purpose Ethernet technology.

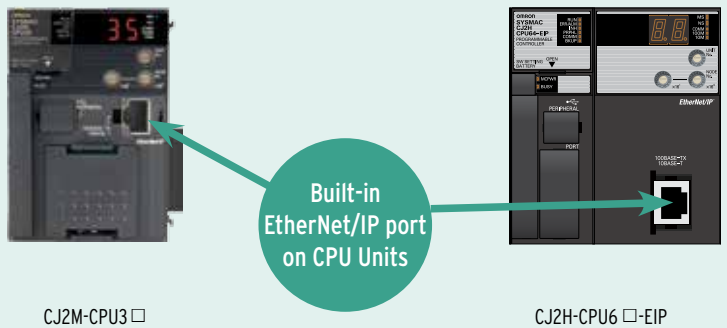

CJ2 CPU Units are available with multifunctional Ethernet ports that are compatible with EtherNet/IP. Peripheral Devices for universal Ethernet Technology (such as Cables, Hubs, and Wireless Devices) can be used with CJ2 CPU Units. Reduces network installation and wiring costs.



Multiple functions can be executed simultaneously on one port.



Support Software, Data Links, Message communications between PLCs, FTP Communications

The port connection does not need to be changed, which makes it easier to build the system.

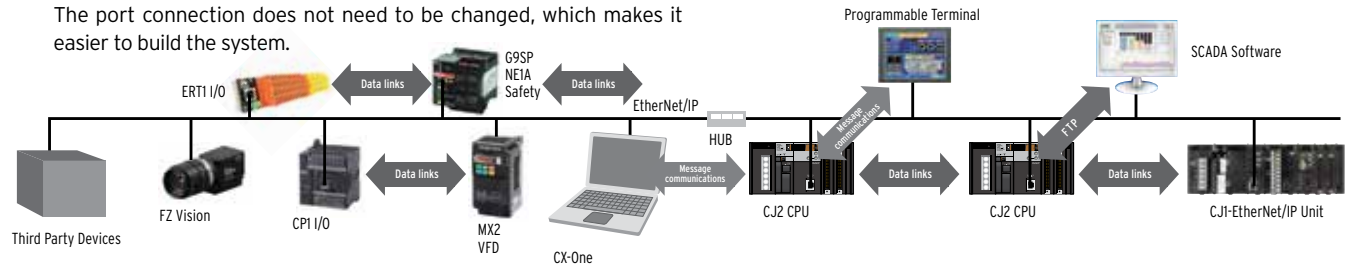

Extremely Fast and High-capacity Data Links



Large Data Transfers with High Reliability

From manufacturing recipes and information on interlocks between processes to production data, any type of data can be exchanged at high speed and at the optimal timing. Communications performance is vastly improved over OMRON's Controller Link and FL-net networks.

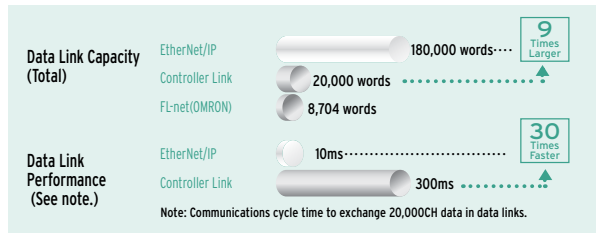

Using the CJ2H built-in EtherNet/IP port (Functionality differs when using the CJ2M built-in EtherNet/IP port)

Efficient Programming with Tag Symbols



There Is Little Effect on Address Changes.

Previously, when data was exchanged by specifying address and addresses were changed, the program had to be changed at other Controllers and various operations, such as memory checks, had to be performed. Now, tag names reduce the dependence on a memory map and the need for checking items affected by changes. This allows equipment to be easily added or upgraded.

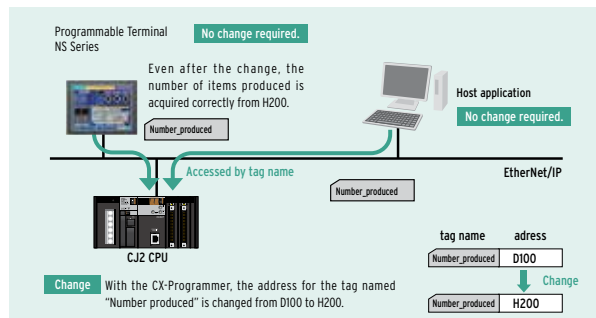

* CJ2H-CPU6 □ -EIP: 20,000 max., CJ2M-CPU3 □ : 2,000 max.

More Flexible Programming, Easier Debugging

Changes to specifications can be handled easily and total lead time is reduced for system startup and troubleshooting.

A Smart Input Function greatly reduces the work required to input programs 50% Reduced

Easy, Intuitive Programming Software

A complete range of intuitive programming functions is provided, including instruction and address input assistance, address incrementing, and address incremental copy. These functions enable waste-free programming with minimal effort.



Highly Readable Programming

The Greatest Program Diversity in the Industry.

- Bit Addresses can be used in the DM Area and EM Area.
- BCD and Binary Timer instructions can be used Together.
- Function blocks make units of processing easy to understand.
- Function block definitions do not take up user program memory capacity.*
- Address offsets can be specified
- Array variables are supported, A symbol can be used for an array variable subscript.
- Structure symbols make it easier to create data structures and data bases.*

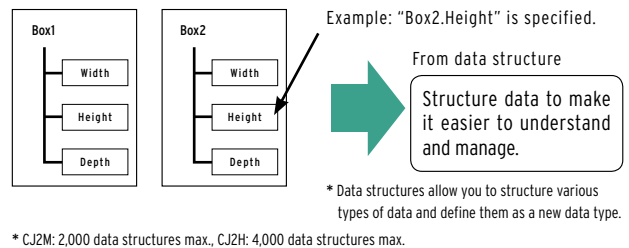
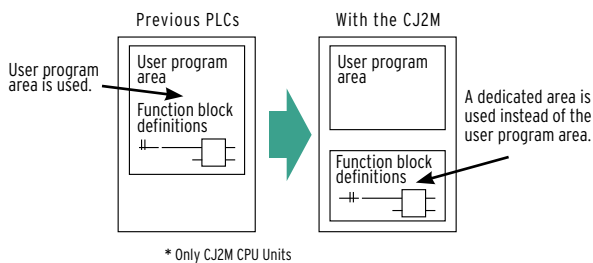

Stress-free Online Debugging

Effects on Machinery Operation Are Reduced.

- The additional cycle time due to online editing has been reduced to approx. 1 ms
- Unlimited ST and SFC online editing

Greatly Improved Debugging Efficiency Through Superior Data Tracing

High-speed, High-capacity Data Tracing Is Now Possible.

Ample Trigger Conditions

One, two, or four words of data and comparison conditions can be specified. For example, a trigger can be set for when double-precision data is larger than a specified value.

CX-One Data Trace Is Also Upgraded.

- The improved CJ2 trace function is fully utilized.
- A function has been added for superimposing trace waveforms
- Trace results can be printed or saved as bit maps.
- The measurement times for two selected points can be checked.

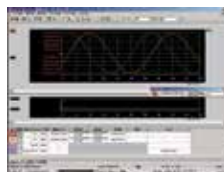

Data Trace

High-capacity Data Tracing

Maximum 32 Kwords (CJ2H) of data can be traced, and the EM Area can also be used as trace memory.

Continuous Data Tracing

Sampled data in the trace memory of the CPU Unit can be regularly collected at the personal computer to enable sampling for long periods or time. Data can be saved in the CSV files in personal computer.

Ideal for Applications Requiring High Speed, Synchronization, and Multiple Axes Helps Improve Machine I/O Throughput

Tension Control

Inconsistencies in I/O processing times are eliminated to reduce takt times.

Use High-speed Analog I/O Units

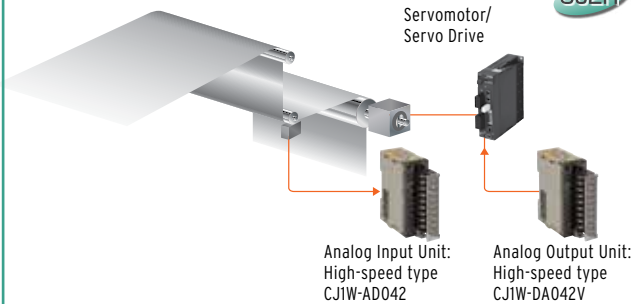

Direct conversion enables faster input of analog values into the CJ2 CPU Unit.

Inline Measurement

Analog quantities are input in ultra-high speed (20μs) to improve the accuracy of NG product detection.

Use High-speed Analog I/O Units



Analog Input Unit:
High-speed type
CJ1W-AD042

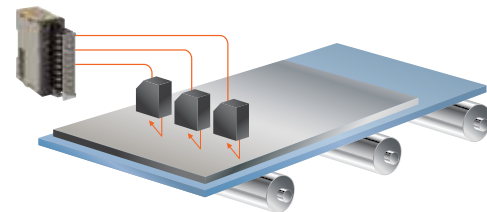

High-speed Serial Input from Laser Distance Meters

Achieve high-speed data input from high-speed measurement sensors, such as laser distance meters and displacement sensors.

Use High-speed Serial Communications Units

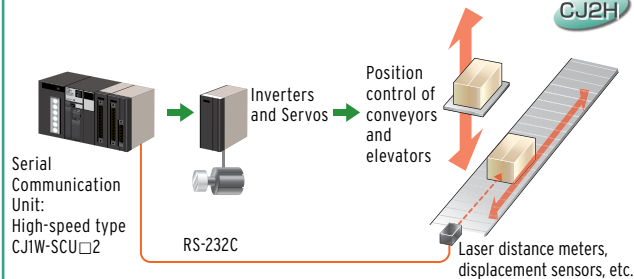

Transfer position data to the CPU Unit from laser distance meters with short measurement cycles without missing data to achieve precise control of inverters for conveyors and elevators.

High-speed Serial Input from Barcode Readers

High-speed Sorting Control Using a Barcode Reader

Use High-speed Serial Communications Units

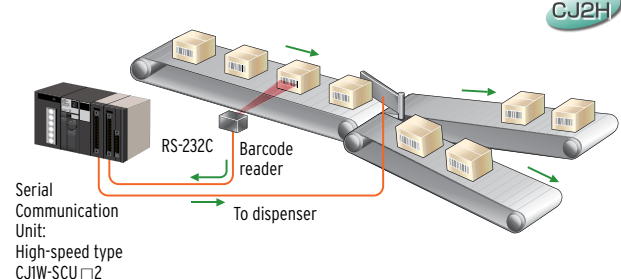

Data from the barcode reader is transferred quickly to the CPU Unit to recognize the code and output pulses at high speed.

Synchronized Control

An electronic cam enables high-precision synchronized control.

Use CJ2H CPU Unit and Position Control Unit

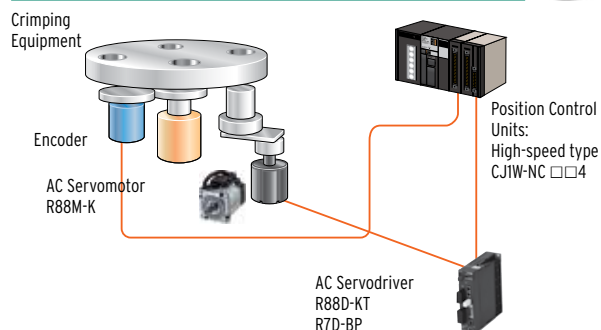

Multi-axis Position Control through EtherCAT

Reduce Production Cycle Time with High-speed Startup at 0.4 ms.

Use CJ2 CPU Unit and Position Control Unit with EtherCAT interface

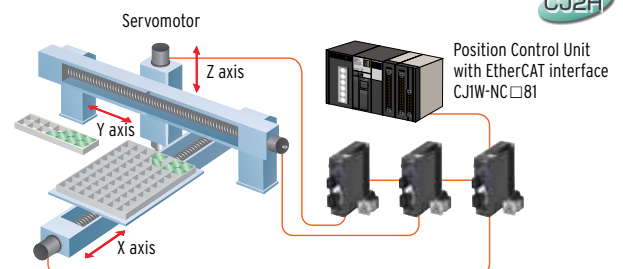

Palletizing: A starting time of 0.4 ms helps reduce the cycle time of applications that perform repeated positioning.

System Configuration

Basic System

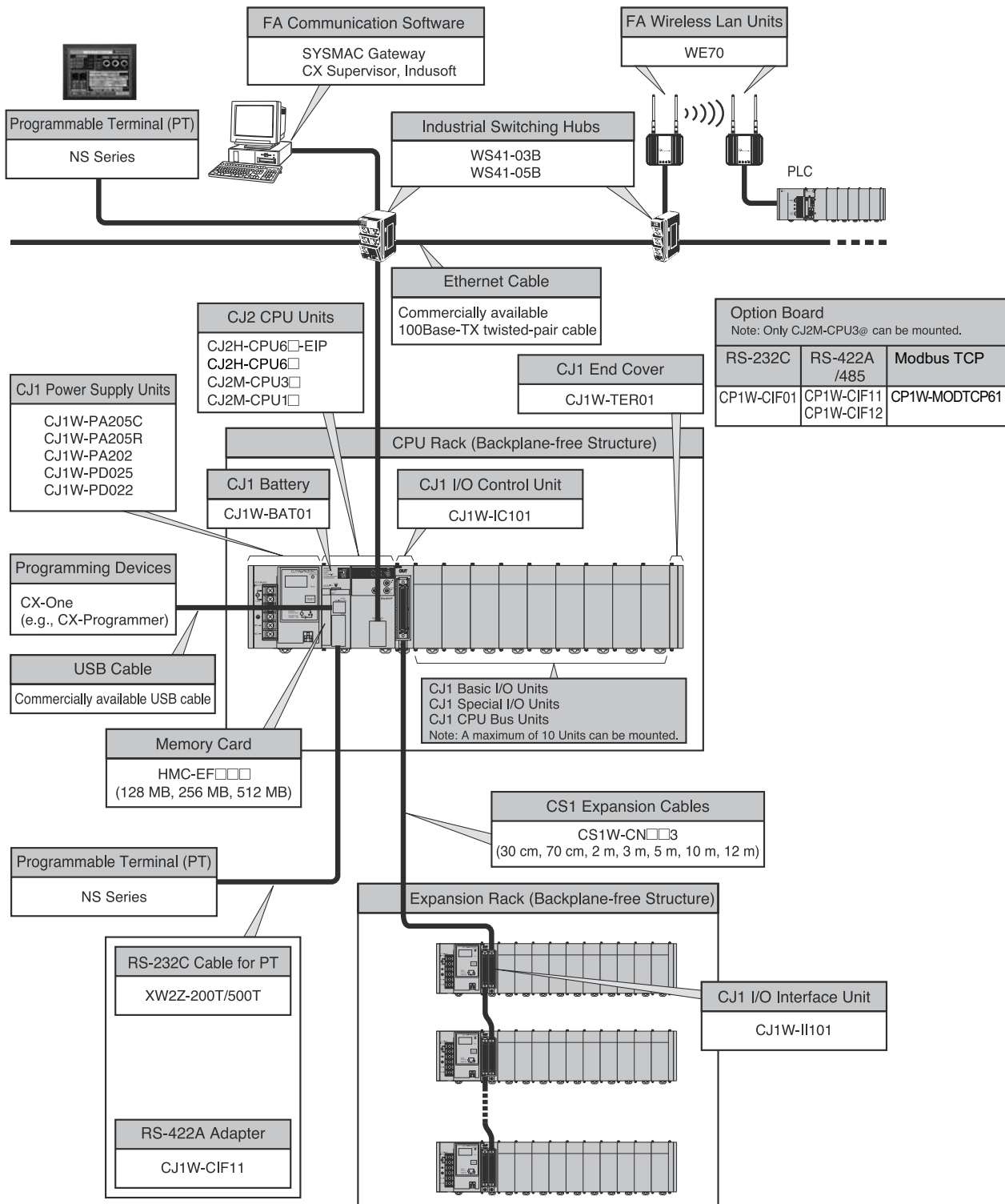

CJ-Series Power Supplies, Expansions

Modular PLC



Power and flexibility

CJ systems can operate on 24 VDC power supply, or on 100 to 240 VAC mains. For small-scale systems with mainly digital I/O a low-cost small-capacity power supply can be used. For systems with many analog I/Os and control/communication units, it may be necessary to use a larger power supply unit.

Depending on the CPU type, up to 3 expansions can be connected to the CPU 'rack', giving a total capacity of 40 I/O units. The total length of the expansion cables of one system may be up to 12 m.

Ordering information

Power supply

Input range	Power consumption	Output capacity at 5 VDC	Output capacity at 24 VDC	Max. output power	Features	Width	Model	Standards
21.6 to 26.4 VDC	35 W max.	2.0 A	0.4 A	16.6 W	–	27 mm	CJ1W-PD022	UC1, CE
19.2 to 28.8 VDC	50 W max.	5.0 A	0.8 A	25 W	–	60 mm	CJ1W-PD025	UC1, N, L, CE
85 to 264 VAC 47 to 63 Hz	50 VA max.	2.8 A	0.4 A	14 W	–	45 mm	CJ1W-PA202	
	100 VA max.	5.0 A	0.8 A	25 W	Run output (SPST relay)	80 mm	CJ1W-PA205R	
					Maintenance status display	80 mm	CJ1W-PA205C	

Note: The CJ1W-PD022 has no galvanic isolation

I/O expansion

Type	Description	Width, Length	Model	Standards
I/O control unit	Required unit on CPU 'rack' to connect I/O expansions	20 mm	CJ1W-IC101	UC1, N, L, CE
I/O interface unit	Start unit for each I/O expansion 'rack'. Requires a power supply unit.	31 mm	CJ1W-II101	
I/O expansion cable	Connects CJ1W-IC101 or -II101 to the next expansion rack's -II101	0.3 m	CS1W-CN313	N, L, CE
		0.7 m	CS1W-CN713	
		2.0 m	CS1W-CN223	
		3.0 m	CS1W-CN323	
		5.0 m	CS1W-CN523	
		10 m	CS1W-CN133	
		12 m	CS1W-CN133-B2	

International Standards

- The standards are abbreviated as follows: U: UL, U1: UL (Class I Division 2 Products for Hazardous Locations), C: CSA, UC: cULus, UC1: cULus (Class I Division 2 Products for Hazardous Locations), CU: cUL, N: NK, L: Lloyd, and CE: EC Directives.
- Contact your OMRON representative for further details and applicable conditions for these standards.

● EC Directives

The EC Directives applicable to PLCs include the EMC Directives and the Low Voltage Directive. OMRON complies with these directives as described below.

● EMC Directives

Applicable Standards
EMI: EN61000-6-4, EN61131-2
EMS: EN61000-6-2, EN61131-2
PLCs are electrical devices that are incorporated in machines and manufacturing installations. OMRON PLCs conform to the related EMC standards so that the devices and machines into which they are built can more easily conform to EMC standards. The actual PLCs have been checked for conformity to EMC standards. Whether these standards are satisfied for the actual system, however, must be checked by the customer.

EMC-related performance will vary depending on the configuration, wiring, and other conditions of the equipment or control panel in which the PLC is installed. The customer must, therefore, perform final checks to confirm that the overall machine or device conforms to EMC standards.

● Low Voltage Directive

Applicable Standard: EN61131-2
VDC must satisfy the appropriate safety requirements. With PLCs, this applies to Power Supply Units and I/O Units that operate in these voltage ranges. These Units have been designed to conform to EN61131-2, which is the applicable standard for PLCs.



Fast and powerful CPUs for any task

The comprehensive lineup of CJ2 processors offer outstanding new features while evolving from the CJ1 series and its proven track record. The wide range of high performance CPU's allow scalability and flexibility for any automation challenge. The CJ2 CPU units offer increased capacity plus built-in USB and ethernet ports, yet are fully compatible with the extensive range of CJ-Series I/O units. CJ2M CPU units can be equipped with pulse I/O option modules to perform position control for up to 4 axes, using dedicated instructions.

Improvements such as structures and arrays, tag based programming, and increased memory capacity ensure fast development and less cost for the user. The CJ2M features communication plug-in modules, more function block memory, and high speed I/O units while the CJ2H CPU's increased program memory area, synchronous unit operation, and fast processors ensure your machine will perform at a level higher than the competition.

Ordering information

Max. digital I/O points	Program capacity	Data memory capacity	Logic execution speed	Max. I/O units	Width	5 V current consumption	Communications	Model	Standards
2,560	400 K	832 K	16 ns	40	80 mm	820 mA	USB + EtherNet/IP + RS-232C	CJ2H-CPU68-EIP	UC1, N, L, CE
2,560	250 K	512 K	16 ns	40	80 mm	820 mA	USB + EtherNet/IP + RS-232C	CJ2H-CPU67-EIP	
2,560	150 K	352 K	16 ns	40	80 mm	820 mA	USB + EtherNet/IP + RS-232C	CJ2H-CPU66-EIP	
2,560	100 K	160 K	16 ns	40	80 mm	820 mA	USB + EtherNet/IP + RS-232C	CJ2H-CPU65-EIP	
2,560	50 K	160 K	16 ns	40	80 mm	820 mA	USB + EtherNet/IP + RS-232C	CJ2H-CPU64-EIP	
2,560	60 K	160 K	40 ns	40	62 mm	700 mA	USB + EtherNet/IP, serial comm. option slot	CJ2M-CPU35	
2,560	30 K	160 K	40 ns	40	62 mm	700 mA	USB + EtherNet/IP, serial comm. option slot	CJ2M-CPU34	
2,560	20 K	64 K	40 ns	40	62 mm	700 mA	USB + EtherNet/IP, serial comm. option slot	CJ2M-CPU33	
2,560	10 K	64 K	40 ns	40	62 mm	700 mA	USB + EtherNet/IP, serial comm. option slot	CJ2M-CPU32	
2,560	5 K	64 K	40 ns	40	62 mm	700 mA	USB + EtherNet/IP, serial comm. option slot	CJ2M-CPU31	
2,560	400 K	832 K	16 ns	40	49 mm	420 mA	USB + RS-232C	CJ2H-CPU68	
2,560	250 K	512 K	16 ns	40	49 mm	420 mA	USB + RS-232C	CJ2H-CPU67	
2,560	150 K	352 K	16 ns	40	49 mm	420 mA	USB + RS-232C	CJ2H-CPU66	
2,560	100 K	160 K	16 ns	40	49 mm	420 mA	USB + RS-232C	CJ2H-CPU65	
2,560	50 K	160 K	16 ns	40	49 mm	420 mA	USB + RS-232C	CJ2H-CPU64	
2,560	60 K	160 K	40 ns	40	31 mm	500 mA	USB + RS-232C	CJ2M-CPU15	
2,560	30 K	160 K	40 ns	40	31 mm	500 mA	USB + RS-232C	CJ2M-CPU14	
2,560	20 K	64 K	40 ns	40	31 mm	500 mA	USB + RS-232C	CJ2M-CPU13	
2,560	10 K	64 K	40 ns	40	31 mm	500 mA	USB + RS-232C	CJ2M-CPU12	
2,560	5 K	64 K	40 ns	40	31 mm	500 mA	USB + RS-232C	CJ2M-CPU11	

Accessories

Description	Remarks	Model	Standards
Pulse I/O option module for CJ2M CPU Units, 2 encoder inputs, 2 pulse outputs	NPN (sinking) outputs	CJ2M-MD211	UC1, N, L, CE
	PNP (sourcing) outputs	CJ2M-MD212	
Memory Cards	Flash Memory, 128 MB	HMC-EF183	N, L, CE
	Flash Memory, 256 MB	HMC-EF283	
	Flash Memory, 512 MB	HMC-EF583	
	Memory Card Adapter (for computer PCMCIA slot)	HMC-AP001	CE
RS-232C Option Board ¹	Serial, Ports: 1 x RS-232C	CP1W-CIF01	UC1, N, L, CE
RS-422A/485 Option Board ¹	Serial, Ports: 1 x RS-422A/485	CP1W-CIF11	
RS422A/485 (isolated) Option Board ¹	Serial, Ports: 1 x RS-422A/485 (isolated)	CP1W-CIF12	
Modbus/TCP Option Board	Modbus/TCP, Ports: 1 x Modbus/TCP	CP1W-MODTCP61	
Thermocouple Option Board	Thermocouple, Ports: 2 x J/K Thermocouple	CP1W-GCTS2	
Battery Set ²	–	CJ1W-BAT01	CE
USB Programming cable	–	CP1W-CN221	

¹ Only used with CJ2M-CPU3□

² Included with the CPU unit

Software

Cx-One FULL	Media	Model	Standards
Single user licence	Licence only	CXONE-AL01-EV□	–
Three user licence	Licence only	CXONE-AL03-EV□	
Ten user licence	Licence only	CXONE-AL10-EV□	
Thirty user licence	Licence only	CXONE-AL30-EV□	
Fifty user licence	Licence only	CXONE-AL50-EV□	
Site licence	Licence only	CXONE-AL0XX-EV□	
Software on CDs	CD	CXONE-CD-EV□	
Software on a DVD	DVD	CXONE-DVD-EV□	

CJ-Series Digital I/O Units

Modular PLC



8 to 64 points per unit – input, output or mixed

Digital I/O units serve as the PLC's interface to achieve fast, reliable sequence control. A full range of units, from high-speed DC inputs to relay outputs, let you adapt to your needs.

CJ-Series units are available with various I/O densities and connection technologies. Up to 16 I/O points can be wired to units with detachable M3 screw terminals or screwless clamp terminals. High-density 32- and 64- point I/O units are equipped with standard 40-pin flat cable-connectors. Prefabricated cables and wiring terminals are available for easy interfacing to high-density I/O units.

Ordering information

Points	Type	Rated voltage	Rated current	Width	Remarks	Connection type ¹	Model	Standards
16	AC input	120 VAC	7 mA	31 mm	–	M3	CJ1W-IA111	UC1, N, L, CE
8	AC input	240 VAC	10 mA	31 mm	–	M3	CJ1W-IA201	
8	DC input	24 VDC	10 mA	31 mm	–	M3	CJ1W-ID201	
16	DC input	24 VDC	7 mA	31 mm	–	M3	CJ1W-ID211	
16	DC input	24 VDC	7 mA	31 mm	Fast-response (15 µs ON, 90 µs OFF)	M3	CJ1W-ID212	
16	DC input	24 VDC	7 mA	31 mm	Inputs start interrupt tasks in PLC program	M3	CJ1W-INT01	
16	DC input	24 VDC	7 mA	31 mm	Latches pulses down to 50 µs pulse width	M3	CJ1W-IDP01	
32	DC input	24 VDC	4.1 mA	20 mm	–	1 x Fujitsu	CJ1W-ID231	
32	DC input	24 VDC	4.1 mA	20 mm	–	1 x MIL ¹ (40 pt)	CJ1W-ID232	
32	DC input	24 VDC	4.1 mA	20 mm	Fast-response (15 µs ON, 90 µs OFF)	1 x MIL ¹ (40 pt)	CJ1W-ID233	
64	DC input	24 VDC	4.1 mA	31 mm	–	2 x Fujitsu	CJ1W-ID261	
64	DC input	24 VDC	4.1 mA	31 mm	–	2 x MIL ¹ (40 pt)	CJ1W-ID262	
8	Triac output	250 VAC	0.6 mA	31 mm	–	M3	CJ1W-OA201	
8	Relay output	250 VAC	2 A	31 mm	–	M3	CJ1W-OC201	
16	Relay output	250 VAC	2 A	31 mm	–	M3	CJ1W-OC211	
8	DC output (sink)	12 to 24 VDC	2 A	31 mm	–	M3	CJ1W-OD201	
8	DC output (source)	24 VDC	2 A	31 mm	With short-circuit protection, alarm	M3	CJ1W-OD202	
8	DC output (sink)	12 to 24 VDC	0.5 A	31 mm	–	M3	CJ1W-OD203	
8	DC output (source)	24 VDC	0.5 A	31 mm	With short-circuit protection, alarm	M3	CJ1W-OD204	
16	DC output (sink)	12 to 24 VDC	0.5 A	31 mm	–	M3	CJ1W-OD211	
16	DC output (source)	24 VDC	0.5 A	31 mm	With short-circuit protection, alarm	M3	CJ1W-OD212	
16	DC output (sink)	24 VDC	0.5 A	31 mm	Fast-response (15 µs ON, 80 µs OFF)	M3	CJ1W-OD213	
32	DC output (sink)	12 to 24 VDC	0.5 A	20 mm	–	1 x Fujitsu	CJ1W-OD231	
32	DC output (source)	24 VDC	0.3 A	20 mm	With short-circuit protection, alarm	1 x MIL ¹ (40 pt)	CJ1W-OD232	
32	DC output (sink)	12 to 24 VDC	0.5 A	20 mm	–	1 x MIL ¹ (40 pt)	CJ1W-OD233	
32	DC output (sink)	24 VDC	0.5 A	20 mm	Fast-response (15 µs ON, 80 µs OFF)	1 x MIL ¹ (40 pt)	CJ1W-OD234	
64	DC output (sink)	12 to 24 VDC	0.3 A	31 mm	–	2 x Fujitsu	CJ1W-OD261	
64	DC output (source)	24 VDC	0.3 A	31 mm	–	2 x MIL ¹ (40 pt)	CJ1W-OD262	
64	DC output (sink)	12 to 24 VDC	0.3 A	31 mm	–	2 x MIL ¹ (40 pt)	CJ1W-OD263	
16+16	DC in+out (sink)	24 VDC	0.5 A	31 mm	–	2 x Fujitsu	CJ1W-MD231	UC1, N, CE
16+16	DC in+out (source)	24 VDC	0.5 A	31 mm	–	2 x MIL ¹ (20 pt)	CJ1W-MD232	UC1, N, L, CE
16+16	DC in+out (sink)	24 VDC	0.5 A	31 mm	–	2 x MIL ¹ (20 pt)	CJ1W-MD233	UC1, N, CE
32+32	DC in+out	24 VDC	0.3 A	31 mm	–	2 x Fujitsu	CJ1W-MD261	
32+32	DC in+out (sink)	24 VDC	0.3 A	31 mm	–	2 x MIL ¹ (40 pt)	CJ1W-MD263	
32+32	DC in+out (TLL)	5 VDC	35 mA	31 mm	–	2 x MIL ¹ (40 pt)	CJ1W-MD563	

¹ MIL = connector according to MIL-C-83503 (compatible with DIN 41651/IEC 60603-1).

Note: All digital I/O unit are designated as basic I/O units.

Accessories

Description	Connection type	Model	Standards
Replacement 18-point screwless terminal blocks for I/O units, pack of 5 pcs.	Screwless	CJ-WM01-18P-5	–
Replacement 18-point screw terminal blocks for I/O units, pack of 5 pcs.	M3	CJ-OD507-18P-5	
I/O terminal block for XW2Z cables	MIL (40pt)	XW2R-□□□□-□ *	
Connection cable between I/O terminal block and I/O unit	MIL (40pt)	XW2Z-□□□□	

*See website for available models.



From basic analog I/O to advanced temperature control

The CJ-series offers a wide choice of analog input units, fit for any application, from low-speed, multi-channel temperature measurement to high-speed, high-accuracy data acquisition. Analog outputs can be used for accurate control or external indication.

Advanced units with built-in scaling, filtering and alarm functions reduce the need for complex PLC programming. High-accuracy process I/O units support an extensive range of sensors, for fast and accurate data acquisition. Temperature control units relieve the PLC CPU of PID calculations and alarm monitoring. These functions are handled autonomously by the unit, offering control performance and autotuning functions similar to stand-alone temperature controllers.

Ordering information

Points	Type	Ranges	Resolution	Accuracy ¹	Conversion time	Width	Remarks	Connection type	Model	Standards
4	Universal analog input	0 to 5 V, 1 to 5 V, 0 to 10 V, 0 to 20 mA, 4 to 20 mA, K, J, T, L, R, S, B Pt100, Pt1000, JPt100	V / I: 1/12000 T/C: 0.1 °C RTD: 0.1 °C	V: 0.3% I: 0.3% T/C: 0.3% RTD: 0.3%	250 ms/ 4 point	31 mm	Universal inputs, with zero/span adjustment, configurable alarms, scaling, sensor error detection	M3	CJ1W-AD04U	UC1, L, CE
4	Analog input	0 to 5 V, 0 to 10 V, -10 to 10 V, 1 to 5 V, 4 to 20 mA	1/8,000	V: 0.2% I: 0.4%	250 µs/ point	31 mm	Offset/gain adjustment, peak hold, moving average, alarms	M3	CJ1W-AD041-V1	UC1, N, L, CE
4	High-speed analog input	1 to 5 V, 0 to 10 V, -5 to 5 V, -10 to 10 V, 4 to 20 mA	1/40,000	V: 0.2% I: 0.4%	35 µs/ 4 points	31 mm	Direct conversion (CJ2H special instruction)	M3	CJ1W-AD042	UC1, CE
8	Analog input	1 to 5 V, 0 to 10 V, -10 to 10 V, 1 to 5 V, 4 to 20 mA	1/8,000	V: 0.2% I: 0.4%	250 µs/ point	31 mm	Offset/gain adjustment, peak hold, moving average, alarms	M3	CJ1W-AD081-V1	UC1, N, L, CE
2	Analog output	0 to 5 V, 0 to 10 V, -10 to 10 V, 1 to 5 V, 4 to 20 mA	1/4,000	V: 0.3% I: 0.5%	1 ms/ point	31 mm	Offset/gain adjustment, output hold	M3	CJ1W-DA021	
4	Analog output	1 to 5 V, 0 to 10 V, -10 to 10 V, 1 to 5 V, 4 to 20 mA	1/4,000	V: 0.3% I: 0.5%	1 ms/ point	31 mm	Offset/gain adjustment, output hold	M3	CJ1W-DA041	
4	High-speed analog output	1 to 5 V, 0 to 10 V, -10 to 10 V	1/40,000	0.3%	35 µs/ 4 points	31 mm	Direct conversion (CJ2H special instruction)	M3	CJ1W-DA042V	UC1, CE
8	Voltage output	0 to 5 V, 0 to 10 V, -10 to 10 V, 1 to 5 V	1/8,000	0.3%	250 µs/ point	31 mm	Offset/gain adjustment, output hold	M3	CJ1W-DA08V	UC1, N, L, CE
8	Current output	4 to 20 mA	1/8,000	0.5%	250 µs/ point	31 mm	Offset/gain adjustment, output hold	M3	CJ1W-DA08C	UC1, N, CE
4 + 2	Analog in + output	1 to 5 V, 0 to 10 V, -10 to 10 V, 1 to 5 V, 4 to 20 mA	1/8,000	in: 0.2% out: 0.3%	1 ms/ point	31 mm	Offset/gain adjustment, scaling, peak hold, moving average, alarms, output hold	M3	CJ1W-MAD42	UC1, N, L, CE
4	Universal analog input	DC voltage, DC current, Thermocouple, Pt100/Pt1000, potentiometer	1/256000	0.05%	60 ms/ 4 points	31 mm	All inputs individually isolated, configurable alarms, maintenance functions, user-defined scaling, zero/span adjustment	M3	CJ1W-PH41U	UC1, CE
2	Process input	4 to 20 mA 0 to 20 mA 0 to 10 V, -10 to 10 V, 0 to 5 V, -5 to 5 V, 1 to 5 V, 0 to 1.25 V, 1.25 to 1.25 V	1/64,000	0.05%	5 ms/ point	31 mm	Configurable alarms, maintenance functions, user-defined scaling, zero/span adjustment, square root, totaliser	M3	CJ1W-PDC15	

CJ-Series Analog I/O and Control Units

Modular PLC

Points	Type	Ranges	Resolution	Accuracy ^{*1}	Conversion time	Width	Remarks	Connection type	Model	Standards
2	Thermocouple input	B, E, J, K, L, N, R, S, T, U, WRe5-26, PLII, -100 to 100 mV	1/64,000	0.05%	5 ms/point	31 mm	Configurable alarms, maintenance functions	M3	CJ1W-PTS15	–
2	Resistance thermometer input	Pt50, Pt100, JPt100, Ni508.4	1/64,000	0.05%	5 ms/point	31 mm	Configurable alarms, maintenance functions	M3	CJ1W-PTS16	UCI, CE
4	Thermocouple Input	B, J, K, L, R, S, T	0.1°C	0.3%	62.5 ms/point	31 mm	4 configurable alarm outputs	M3	CJ1W-PTS51	–
4	Resistance thermometer input	Pt100, JPt100	0.1°C	0.3%	62.5 ms/point	31 mm	4 configurable alarm outputs	M3	CJ1W-PTS52	UCI, CE
6	Thermocouple input	K-type (-200 to 1,300°C) J-Type (-100 to 850°C)	0.1°C	0.5%	40 ms/point	31 mm	Basic I/O unit, setup by DIP switches, adjustable filtering 10/50/60 Hz	M3	CJ1W-TS561	–
6	Resistance thermometer input	Pt100 (-200 to 650°C) Pt1000 (-200 to 650°C)	0.1°C	0.5%	40 ms/point	31 mm	Basic I/O unit, setup by DIP switches, adjustable filtering 10/50/60 Hz	M3	CJ1W-TS562	–
4	Temperature control loops, Thermocouple	B, J, K, L, R, S, T	0.1°C	0.3%	500 ms total	31 mm	4 control outputs: NPN open collector, 100 mA max.	M3	CJ1W-TC001	UCI, N, L, CE
4	Temperature control loops, Thermocouple	B, J, K, L, R, S, T	0.1°C	0.3%	500 ms total	31 mm	4 control outputs: PNP open collector, 100 mA max.	M3	CJ1W-TC002	
2	Temperature control loops, Thermocouple	B, J, K, L, R, S, T	0.1°C	0.3%	500 ms total	31 mm	2 control outputs: NPN open collector, 100 mA max., 2 current transformer inputs for heater burnout detection.	M3	CJ1W-TC003	
2	Temperature control loops, Thermocouple	B, J, K, L, R, S, T	0.1°C	0.3%	500 ms total	31 mm	2 control outputs: PNP open collector, 100 mA max., 2 current transformer inputs for heater burnout detection.	M3	CJ1W-TC004	
4	Temperature control loops, RTD	Pt100, JPt100	0.1°C	0.3%	500 ms total	31 mm	4 control outputs: NPN open collector, 100 mA max.	M3	CJ1W-TC101	
4	Temperature control loops, RTD	Pt100, JPt100	0.1°C	0.3%	500 ms total	31 mm	4 control outputs: PNP open collector, 100 mA max.	M3	CJ1W-TC102	
2	Temperature control loops, RTD	Pt100, JPt100	0.1°C	0.3%	500 ms total	31 mm	2 control outputs: NPN open collector, 100 mA max., 2 current transformer inputs for heater burnout detection.	M3	CJ1W-TC103	
2	Temperature control loops, RTD	Pt100, JPt100	0.1°C	0.3%	500 ms total	31 mm	2 control outputs: PNP open collector, 100 mA max., 2 current transformer inputs for heater burnout detection.	M3	CJ1W-TC104	

*1 Accuracy for Voltage and Current Inputs/Outputs as percentage of full scale and typical value at 25°C ambient temperature (Consult the operation manual for details)
Accuracy for Temperature Inputs/Outputs as percentage of process value and typical value at 25°C ambient temperature (Consult the operation manual for details)

Note: All Analog I/O units are designated as Special I/O units, except TS561/TS562, which are Basic I/O units (cannot be used with CP1H).

Accessories

Description	Connection type	Model	Standards
Replacement 18-point screwless terminal blocks for I/O units, pack of 5 pcs.	Screwless	CJ-WM01-18P-5	–
Replacement 18-point screw terminal blocks for I/O units, pack of 5 pcs.	M3	CJ-OD507-18P-5	–

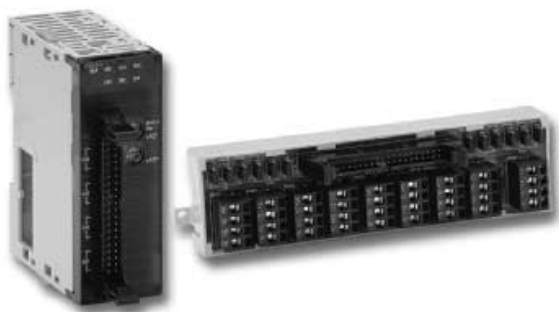

Add motion control to any CJ-Series PLC

From simple position measurement to multi-axis synchronized motion control, the CJ-Series offers a full range of units:

- Counter units gather position information from SSI- or incremental encoders. Actual positions are compared with internally stored target values.
- CJ2M CPU Units have dedicated positioning functions that can be used by installing up to 2 Pulse I/O option modules.
- Position Control units are used for point-to-point positioning with servo drives or stepper motors. Target data and acceleration/deceleration curves can be adjusted on-the-fly.
- Position Control units equipped with EtherCAT.

Ordering information

Channels/ Axes	Type	Signal type	Unit class	Width	Remarks	Connection type	Model	Standards
2	SSI inputs (absolute position data)	Synchronous serial protocol	Special I/O unit	31 mm	Baud rate, encoding type, data length, etc. can be set per channel	M3 screw	CJ1W-CTS21-E	–
2	500 kHz Counter	24 V, line driver	Special I/O unit	31 mm	2 configurable digital inputs + outputs	1 x Fujitsu (40 pt)	CJ1W-CT021	UC1, N, L, CE
4	100 kHz Counter	Line driver, 24 V via terminal block	Special I/O unit	31 mm	Target values trigger interrupt to CPU	1 x MIL (40 pt)	CJ1W-CTL41-E	–
1	DC Motor Control unit	PWM (24 V/4 A)	Special I/O unit	31 mm	4 configurable digital inputs + 50 kHz counter input	3 x Screwless	CJ1W-DCM11-E	–
2	Pulse I/O option module for CJ2M CPU	24 V, line driver	CPU Option Module	20 mm	100 kpps encoder inputs and pulse outputs, NPN (sinking), interrupt / fast response inputs	1 x MIL (40 pt)	CJ2M-MD211	UC1, N, L, CE
2	Pulse I/O option module for CJ2M CPU	24 V, line driver	CPU Option Module	20 mm	100 kpps encoder inputs and pulse outputs, PNP (sourcing), interrupt / fast response inputs	1 x MIL (40 pt)	CJ2M-MD212	–
1	Position Control unit	24 V open collector	Special I/O unit	31 mm	500 kpps pulse outputs, inputs for origin, limit switches, stop, interrupt	1 x Fujitsu (40 pt)	CJ1W-NC113	UC1, CE
2	Position Control unit	24 V open collector	Special I/O unit	31 mm	500 kpps pulse outputs, inputs for origin, limit switches, stop, interrupt	1 x Fujitsu (40 pt)	CJ1W-NC213	–
4	Position Control unit	24 V open collector	Special I/O unit	31 mm	500 kpps pulse outputs, inputs for origin, limit switches, stop, interrupt	2 x Fujitsu (40 pt)	CJ1W-NC413	–
2	Position Control Unit High speed type	24 V open collector	Special I/O Unit	51 mm	500 kpps pulse outputs, built-in feedback pulse counters, synchronous multi-axis control	MIL	CJ1W-NC214	–
4	Position Control Unit High speed type	24 V open collector	Special I/O Unit	62 mm	500 kpps pulse outputs, built-in feedback pulse counters, synchronous multi-axis control	MIL	CJ1W-NC414	–
4	Position Control Unit	EtherCAT	CPU Bus Unit	31 mm	Control commands executed by EtherCAT communications. Positioning functions: memory operation, direct operation by ladder programming. I/O communication: 64 nodes	1 x RJ45 (shielded)	CJ1W-NC482	UC1, CE
8	Position Control Unit	EtherCAT	CPU Bus Unit	31 mm	Control commands executed by EtherCAT communications. Positioning functions: memory operation, direct operation by ladder programming. I/O communication: 64 nodes	1 x RJ45 (shielded)	CJ1W-NC882	–

Note: Line driver signal type units also available. Note: See website for all available models.

Accessories

Description	Connection type	Model	Standard
I/O terminal block	Fujitsu or MIL	XW2R-□□□□-□*	–
Screwless terminal block for connecting 24 V or Line driver encoders to CJ1W-CTL41-E	MIL (40 pt.) to 32 pt. screwless clamp	XW2G-40G7-E	–
General purpose I/O connection cable for I/O units with 40-pt. Fujitsu connector (___ = length in cm)	Fujitsu (40 pt.) to MIL (40 pt.)	XW2Z-___B	–
General purpose I/O connection cable for I/O units with 40-pt. MIL connector (___ = length in cm)	2 x MIL (40 pt)	XW2Z-___K	–
Servo relay unit 1-Axis position control unit	–	XW2B-20J6-1B	–
Servo relay unit 2-Axes position control unit	–	XW2B-40J6-2B	–
Cable connecting servo relay unit to Position control unit CJ1W-NC113, cable length 1 m. For Sigma-5 and Sigma-II servo drives.	–	XW2Z-100J-A14	–
Cable connecting servo relay unit to Position control unit CJ1W-NC213/413, cable length 1 m. For Sigma-5 and Sigma-II servo drives.	–	XW2Z-100J-A15	–
Cable connecting servo relay unit to Position control unit CJ1W-NC113, cable length 1 m. For SmartStep servo drives.	–	XW2Z-100J-A16	–
Cable connecting servo relay unit to Position control unit CJ1W-NC213/413, cable length 1 m. For SmartStep servo drives.	–	XW2Z-100J-A17	–
Cable connecting servo relay unit to Position control unit CJ1W-NC133, cable length 1 m. For Sigma-5 and Sigma-II servo drives.	–	XW2Z-100J-A18	–
Cable connecting servo relay unit to Position control unit CJ1W-NC233/433, cable length 1 m. For Sigma-5 and Sigma-II servo drives.	–	XW2Z-100J-A19	–
Cable connecting servo relay unit to Position control unit CJ1W-NC133, cable length 1 m. For SmartStep servo drives.	–	XW2Z-100J-A20	–
Cable connecting servo relay unit to Position control unit CJ1W-NC233/433, cable length 1 m. For SmartStep servo drives.	–	XW2Z-100J-A21	–
Cable connecting servo relay unit to Sigma-5 and Sigma-II servo drives, cable length 1 m.	–	XW2Z-100J-B4	–
Cable connecting servo relay unit to SmartStep servo drive, cable length 1 m.	–	XW2Z-100J-B5	–

*Please see website for available XW2R terminal blocks and connecting cables

CJ-Series Communication Units

Modular PLC

Open to any communication

The CJ-Series offers both standard open networks interfaces, and high-speed proprietary network links. Datalinks between PLCs, or to higher-level information systems can be made using serial or Ethernet links.



Ordering information

Type	Ports	Data transfer	Protocols	Unit class	Width	Connection type	Model	Standards
Serial	2 x RS-232C		CompoWay/F, Host link, NT link, Modbus, User-defined	CPU bus unit	31 mm	9-pin D-Sub	CJ1W-SCU21-V1	UC1, N, L, CE
Serial	2 x RS-232C	High-speed	CompoWay/F, Host link, NT link, Modbus, User-defined	CPU bus unit	31 mm	9-pin D-Sub	CJ1W-SCU22	
Serial	2 x RS-422A/ RS-485		CompoWay/F, Host link, NT link, Modbus, User-defined	CPU bus unit	31 mm	9-pin D-Sub	CJ1W-SCU31-V1	
Serial	2 x RS-422A/ RS-485	High-speed	CompoWay/F, Host link, NT link, Modbus, User-defined	CPU bus unit	31 mm	9-pin D-Sub	CJ1W-SCU32	
Serial	1 x RS-232C + 1 x RS-422/		CompoWay/F, Host link, NT link, Modbus, User-defined	CPU bus unit	31 mm	9-pin D-Sub	CJ1W-SCU41-V1	
Serial	1 x RS-232C + 1 x RS-422/	High-speed	CompoWay/F, Host link, NT link, Modbus, User-defined	CPU bus unit	31 mm	9-pin D-Sub	CJ1W-SCU42	
Ethernet	1 x 100 Base-Tx		UDP, TCP/IP, FTP server,SMTP (e-mail), SNTP (time adjust), FINS routing, socket service	CPU bus unit	31 mm	RJ45	CJ1W-ETN21	
EtherNet/IP	1 x 100 Base-Tx		EtherNet/IP, UDP, TCP/IP, FTP server, SNTP, SNMP	CPU Bus unit	31 mm	RJ45	CJ1W-EIP21	
Controller link	2-wire twisted pair		Omron proprietary	CPU bus unit	31 mm	2-wire screw + GND	CJ1W-CLK23	
DeviceNet	1 x CAN		DeviceNet	CPU bus unit	31 mm	5-p detachable	CJ1W-DRM21	
PROFIBUS-DP	1 x RS-485		DP, DPV1	CPU bus unit	31 mm	9-pin D-Sub	CJ1W-PRM21	UC, CE
PROFIBUS-DP	1 x RS-485		DP	Special I/O unit	31 mm	9-pin D-Sub	CJ1W-PRT21	
PROFINET-IO	1 x 100 Base-Tx		PROFINET-IO Controller, FINS/UDP	CPU Bus unit	31 mm	RJ45	CJ1W-PNT21	
CompoNet	4-wire, data + power to slaves (Master)		CompoNet (CIP-based)	Special I/O unit	31 mm	4-p detachable IDC or screw	CJ1W-CRM21	U1, N, L, CE
CompoBus/S	2-wire (Master)		Omron proprietary	Special I/O unit	20 mm	2-wire screw + 2-wire power	CJ1W-SRM21	UC1, N, L, CE

Accessories

Description	Connection type	Model	Standards
RS-232C to RS-422/RS-485 signal converter. Mounts directly on serial port.	9-pin D-sub to screw clamp terminals	CJ1W-CIF11	-
Controller link PCI board with support software	PCI, wired CLK	3G8F7-CLK21-EV1	
Controller link repeater unit (wire to wire)	Screw - Screw	CS1W-RPT01	
Controller link repeater unit (wire to HPCF fibre)	Screw - HPCF connector	CS1W-RPT02	
Controller link repeater unit (wire to graded-index glass fibre)	Screw - ST connector	CS1W-RPT03	

OMRON AUTOMATION AND SAFETY • THE AMERICAS HEADQUARTERS • Schaumburg, IL USA • 847.843.7900 • 800.556.6766 • www.omron247.com

OMRON CANADA, INC. • HEAD OFFICE

Toronto, ON, Canada • 416.286.6465 • 866.986.6766 • www.omron247.com

OMRON ELECTRONICS DE MEXICO • HEAD OFFICE

México DF • 52.55.59.01.43.00 • 001.800.556.6766 • mela@omron.com

OMRON ELECTRONICS DE MEXICO • SALES OFFICE

Apodaca, N.L. • 52.81.11.56.99.20 • 001.800.556.6766 • mela@omron.com

OMRON ELETRÔNICA DO BRASIL LTDA • HEAD OFFICE

São Paulo, SP, Brasil • 55.11.2101.6300 • www.omron.com.br

OMRON ARGENTINA • SALES OFFICE

Cono Sur • 54.11.4783.5300

OMRON CHILE • SALES OFFICE

Santiago • 56.9.9917.3920

OTHER OMRON LATIN AMERICA SALES

54.11.4783.5300

OMRON EUROPE B.V. • Wegalaan 67-69, NL-2132 JD, Hoofddorp, The Netherlands. • Tel: +31 (0) 23 568 13 00 • Fax: +31 (0) 23 568 13 88 • www.industrial.omron.eu

Authorized Distributor:

Automation Control Systems

- Machine Automation Controllers (MAC) • Programmable Controllers (PLC)
- Operator interfaces (HMI) • Distributed I/O • Software

Drives & Motion Controls

- Servo & AC Drives • Motion Controllers & Encoders

Temperature & Process Controllers

- Single and Multi-loop Controllers

Sensors & Vision

- Proximity Sensors • Photoelectric Sensors • Fiber-Optic Sensors
- Amplified Photomicrosensors • Measurement Sensors
- Ultrasonic Sensors • Vision Sensors • RFID/Code Readers

Industrial Components

- Relays • Pushbuttons & Indicators • Limit and Basic Switches • Timers
- Counters • Metering Devices • Power Supplies

Safety

- Laser Scanners • Safety Mats • Edges and Bumpers
- Programmable Safety Controllers • Light Curtains • Safety Relays
- Safety Interlock Switches