



L I N E A R G U I D A N C E

1st Edition



HISTORY

In 1969, Joseph H. Nook Jr. founded Nook Industries, Inc., intent on becoming a global supplier of Linear Motion products. Ball screws, both rolled and ground, were the cornerstone products in the early 1970's, putting Nook Industries on the map as a successful business and a trusted company.

Through the years, Nook Industries has served as a leading manufacturer of engineered products. From the first ball screws

to the latest technologies, Nook Industries strives to provide customers with high quality products and engineered solutions.

Companies around the world depend on the quality products provided by Nook Industries to ensure their success. Nook Industries provides a complete line of linear motion products, serving a wide range of market segments.

MARKET SEGMENTS SERVED



Aerospace



Packaging



Automotive



Electronics



Transportation



Tire Manufacture



Entertainment



Semiconductor



Military and Defense



Factory Automation



Pulp & Paper



Steel



Chemical



Medical & Diagnostic



MISSION

Pairing traditional and proven design with the latest technology, Nook Industries manufactures products that customers value. The expansion of product lines and the development of application specific components and engineered systems have propelled Nook Industries to the forefront of the industry.

Nook Industries is committed to customer satisfaction and providing high-quality, high-value products that are delivered on time at a competitive price.

PARTNERS



STANDARD PROFILE BALL RAILS.....2 - 47

Profile Rail Technical Introduction.....	4
Profile Rail and Runner Block	
Technical Data	23
Heavy Load Type	24
Heavy Load High Speed Type	32
Heavy Load Compact Type	40
Design Order Specification Fax Forms	47

NARC /NHRC CAGED BALL PROFILE RAIL SERIES..... 48 - 67

Product Design	52
Installation Notice.....	54
Technical Information.....	55
Ordering Information	57
Dimensions Tables.....	58

MINIATURES LINEAR GUIDES 68 - 109

Product Information	70
Technical Information.....	73
Installation Illustration.....	78
Ordering Information	80
Dimensions and Specifications.....	82

CROSS ROLLER RAILS /CROSS BALL RAILS / CROSS ROLLER ASSEMBLIES 110 - 161

Product Introduction	112
Cross Roller Rails.....	118
Cross Roller Rails - Plastic Retainer.....	124
Cross Ball Rails	131
Cross Roller Assemblies.....	136
Material Comparison	160
Cryogenic Technical Information	161
Lubrication Compatibility Request.....	161

SLIDE SYSTEMS 162 - 187

Features.....	164
Bearing Design Considerations	166
Slide System Design Considerations.....	168
Carriage Mounting Plates	172
Series 100 Slides	173
Series 200 Slides.....	182

ROUND RAILS /LINEAR BEARINGS 188 - 207

Linear Bearing Types and Linear Shafting	190
Self - Aligning Bearings and LLB Bearings.....	192
Linear Bearing Seal Specifications.....	198
Linear Bearing Lubrication	198
Precision Hg Shafting	199
Precision End Machining	201
Precision Hardened Ground Linear Shafting.....	202
Shaft Support Blocks	203
Shaft Support Rail Assemblies.....	203
Shaft Support Rails	204
Metric Linear Bearings	206
Precision Hardened Ground	
Metric Linear Shafting	207

REQUEST FOR QUOTATION208

UNIT CONVERSION209

STANDARD PROFILE BALL RAILS



Nook Standard Profile Ball Rails used in guiding a CNC router.

LINEAR GUIDANCE

STANDARD PROFILE BALL RAIL



PROFILE RAIL TECHNICAL INTRODUCTION	4
Linear Guide Features and Benefits	4
Type of Runner Blocks.....	6
Product Overview and Part Number Reference	7
Accuracy Standards and Recommendations.....	8
Accuracy Tolerance and Parallelism	9
Rail Manufacturing and Straightness.....	10
Preload and Rigidity.....	11
Life Calculation	12
Design Recommendations	18
Bellows.....	20
Lubrication and Sealing	21
Data Plane and Grease Fitting.....	22
PROFILE RAIL AND RUNNER BLOCK TECHNICAL DATA	23
HEAVY LOAD TYPE	24
Linear Guide Overview and Features	25
NH-EA/NH-LEA Series	26
Heavy Load - Flange-Mount - Four Tapped Holes	
NH-EB/NH-LEB Series	28
Heavy Load - Flange-Mount - Four Thru Holes	
NH-ER/NH-LER Series	30
Heavy Load - Narrow Width - Four Tapped Holes	
HEAVY LOAD HIGH SPEED TYPE	32
Linear Guide Overview and Features	33
NH-TA/NH-TAH Series	34
Heavy Load - High Speed - Four Tapped Holes	
NH-TB Series	36
Heavy Load - High Speed - Four Thru Holes	
NH-TR Series	38
Heavy Load - High Speed - Four Tapped Holes	
HEAVY LOAD COMPACT TYPE	40
Linear Guide Overview and Features	41
NU-ER/NU-SER Series	42
Heavy Load - Compact - Two or Four Tapped Holes	
DESIGN ORDER SPECIFICATION FAX FORMS	
Single Guide Rail	44
Two Guide Rails.....	45
Three Guide Rails	46
Application Data Form	47

PRECISION PROFILE BALL RAIL

PRECISE LINEAR MOTION

- The reference face and four grooves are ground simultaneously by special grinding machines
- Simple construction of the runner block
- The rail's high degree of straightness enhances final installation accuracy

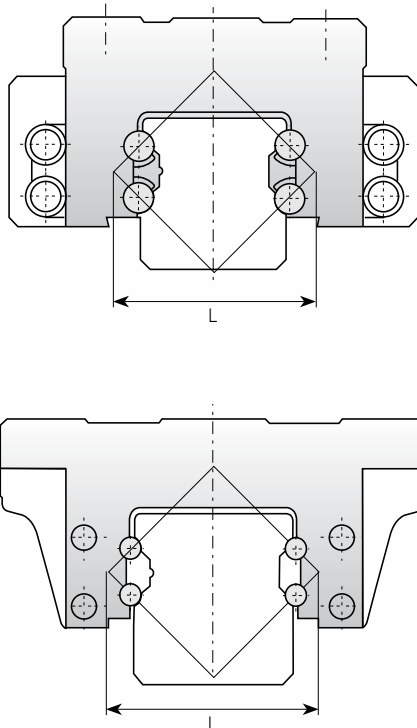

FEATURES AND BENEFITS

Equal Load Carrying Capacity in Four Directions

- Steel bearing balls recirculate between the rail and the runner block and contact both surfaces at a 45° angle. Equal load can be applied bi-directionally in both horizontal and vertical axes. The Nook System is also capable of withstanding moment loads.

High Rigidity and High Moment Rigidity

- The benefits of full radius ball raceways are well established in the manufacture of precision ball screws. The circular shape provides ideal ball to ball raceway contact giving greater system rigidity
- The precise geometry of the square configuration of the ball raceway is ideal for preloading and provides high system rigidity
- A range of preloads are available depending upon the requirements for rigidity and load capacity
- The precise geometry of the square configuration of the ball raceway is ideal for preloading and provides high system rigidity

LINEAR GUIDANCE

STANDARD PROFILE BALL RAIL



Smooth Operation at Both High and Low Speeds

- Precision ground full radius ball tracks provide smooth ball circulation and reduced friction
- The unique ball recirculation design permits stable, high speed travel

Reliability

- High quality materials are hardened by an advanced heat treatment system resulting in increased durability and performance
- Direct lubrication to ball grooves through a grease fitting insures adequate lubrication. The one-piece seal design retains lubricant and effectively protects against contamination
- Full radius ball raceways self-align to help absorb small mounting errors and distributes related stresses evenly
- The Nook Profile Rail design has been extensively tested to insure long reliable life

Versatile Installation

The compact design of Nook runner blocks offers greater design flexibility and several methods of mounting compared to other linear guidance systems. Special retainers and recirculation tubes prevent balls from escaping when the runner block is removed from the rail. (remove slowly with no-load)

The combined effect of the features listed above results in the following advantages:

- (1) Improved working accuracy
- (2) Greater performance control at low speed
- (3) Low temperature operation at high speed
- (4) Low friction
- (5) Reduced machining and assembly costs
- (6) Easy maintenance

PROFILE BALL RAIL

RUNNER BLOCK TYPES

Nook Precision Profile Rails are available in two designs. One design utilizes steel return tubes for ball recirculation (NH-TA, NH-TB, NH-TR) and the other utilizes a plastic end cap for ball recirculation (NH-LEA, NH-LEB, NH-LER, NH-EA, NH-EB, NH-ER, NU-ER, NU-SER).

The tube type recirculation system enables the carriage to be used for higher speed applications. The plastic end cap runner block is narrower in width than the return tube style block. Depending upon the requirements of height, loads, mounting holes, etc. the users may choose from eight different options.

LOAD

H	Heavy Load
U	Heavy Load Compact
N	Medium Load

BLOCK

	Normal Runner Block
L	Long Runner Block
S	Short Runner Block

RETURN SYSTEM

E	End Cap Type
T	Tube Type

MOUNTING HOLES

A	Tapped Hole On Flange
B	Drilled Hole On Flange
R	Tapped Hole Runner Block

EXAMPLES:

N	H	25		E	A
	Heavy Load		Normal Runner Block	End Cap Type	Tapped Hole On Flange
N	U	30	S	E	R
	Heavy Load Compact		Short Runner Block	End Cap Type	Tapped Hole Runner Block

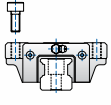
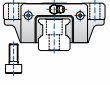
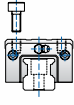
CLASSIFICATION	ULTRA HEAVY LOAD TYPE - WITH LONG RUNNER BLOCK		
	Flange Type		Narrow Width
Model	NH-LEA	NH-LEB	NH-LER
Runner Block Mounting Direction			
Permissible Speed (m/min)	120	120	120
Accuracy Grade (C1=precision, C7=commercial)	C001-C7	C001-C7	C001-C7
Preload (T=clearance, T3=heavy, TO=very light)	T0 - T3	T0 - T3	T0 - T3
Vibration Behavior	○	○	○
Noise	○	○	○
Page Number	26-27	28-29	30-31

Coefficient of friction: 0.005 max (rolling)

Heat resistance: 80°C (100°C with special insulation)

Corrosion resistance: Hard chrome plating, RAYDENT™ coating and black chrome plating available as options

Lubrication: Lithium based grease. (Lubricate every six months or after every 100 Km of travel)

Seals: Other than standard equipped seals, there are bellows, cap plugs and scrapers available as options

REFERENCE NUMBER SYSTEM

The following numbers are used to reference the type of Nook Precision Profile Rail Systems.

When placing an order, please specify the numbers by referring to the following guide.

ASSEMBLY

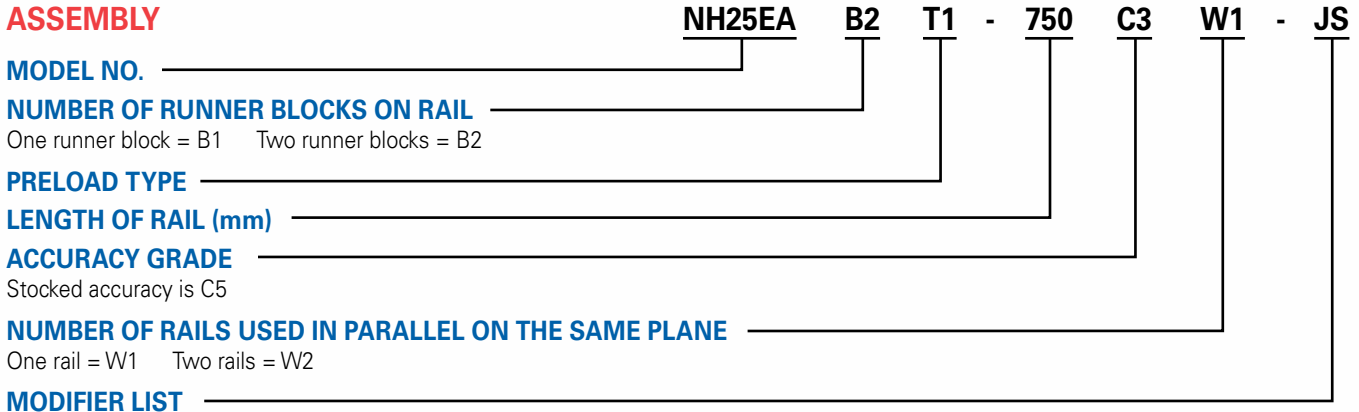

MODEL NO.

NUMBER OF RUNNER BLOCKS ON RAIL

One runner block = B1 Two runner blocks = B2

PRELOAD TYPE

LENGTH OF RAIL (mm)

ACCURACY GRADE

Stocked accuracy is C5

NUMBER OF RAILS USED IN PARALLEL ON THE SAME PLANE

One rail = W1 Two rails = W2

MODIFIER LIST

J = Butt-jointing rail

G = Customer designated lubricant

I = Attached inspection report

S = Standard, no additional description required

M = Modified, additional description required

C = Chrome surface treatment is applied to the casing and track rail

CR = Chrome surface treatment is applied to the track rail

RAIL ONLY

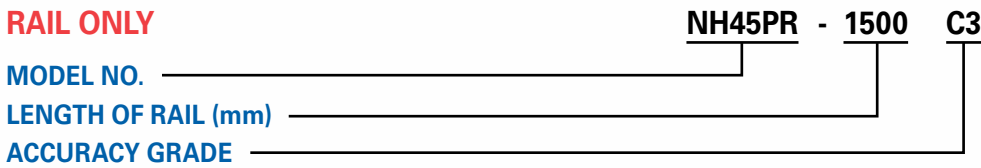

MODEL NO.

LENGTH OF RAIL (mm)

ACCURACY GRADE

HEAVY LOAD TYPE						MEDIUM LOAD TYPE	
High Speed			Flange Type		Narrow Width	Compact High Rigidity	
NH-TA	NH-TB	NH-TR	NH-EA	NH-EB	NH-ER	NU-ER	NU-SER
200	200	200	120	120	120	120	120
C001-C7	C001-C7	C001-C7	C001-C7	C001-C7	C001-C7	C001-C7	C001-C7
T0 - T3	T0 - T3	T0 - T3	T0 - T3	T0 - T3	T0 - T3	T0 - T3	T0 - T3
●	●	●	○	○	○	○	○
●	●	●	○	○	○	○	○
34-35	36-37	38-39	26-27	28-29	30-31	42-43	42-43

See unit conversion on page 209.

○ Low

● Very Low

ACCURACY STANDARDS & RECOMMENDATIONS

Nook Precision Profile Rail Systems are available in six standard classes. The selected accuracy grade should match the positioning accuracy and parallelism requirements of the machines.

The grade of the Profile Rail System should be matched to the ball screw if used.

		ACCURACY STANDARDS									
Rail Accuracy Grade		C001 Ultra Precision	C01 Super Precision	C1 Precision	C3 High Precision	C5* Standard Precision	C7 Commercial Precision				
Type H Accuracy		●	●	●	●	●	●				
Type U Accuracy		●	●	●	●	●	●				
Type N Accuracy		●	●	●	●	●	●				
		ACCURACY OF ELEMENTS									
Height H** (unit: μm)											
Dimension Tolerance		±5	±10	±20	±40	±80	±200				
Pair Variation		3	5	7	15	25	100				
Width N** (unit: μm)											
Dimension Tolerance		±8	±15	±25	±50	±100	±200				
Pair Variation		3	7	10	20	30	150				
		ACCURACY RECOMMENDATION OF BALL SCREWS AND PROFILE RAILS									
Accuracy Grade		C0		C1	C2	C3	C4	C5	C6	C10	
Numerical Controlled Machines	Lathes	X	●	●	●	●	●				
		Z					●	●	●		
	Machining Centers	X			●	●	●	●			
		Y			●	●	●	●			
		Z				●	●	●	●		
	Grinding Machines	X	●	●	●	●					
		Z			●	●	●				
	EDM	X			●	●	●				
		Y			●	●	●				
		Z				●	●	●			
	Semiconductor Manufacturing Equipment		●	●	●	●					
	Non-CNC Machine Tools							●	●	●	●
General Industrial Machines								●		●	

See unit conversion on page 209.

* Stocked Accuracy–C5

**See FIG. 1 page 9

● = Available–Non stock

ACCURACY

Please select the most suitable grade of Nook Precision Profile Rail System for your application. For accuracy requirements beyond the tolerances indicated or for any special requirements, please contact Nook application engineers.

RUNNING PARALLELISM

Running Parallelism is defined as the error in the parallelism between the datum planes of the rail and the runner block as the runner block is moved along its entire travel length.

DIFFERENCES IN HEIGHT "H"

This defines the difference between the maximum and minimum heights "H" of the runner blocks that are mounted on the same rail. (See FIG. 1)

FIG. 1

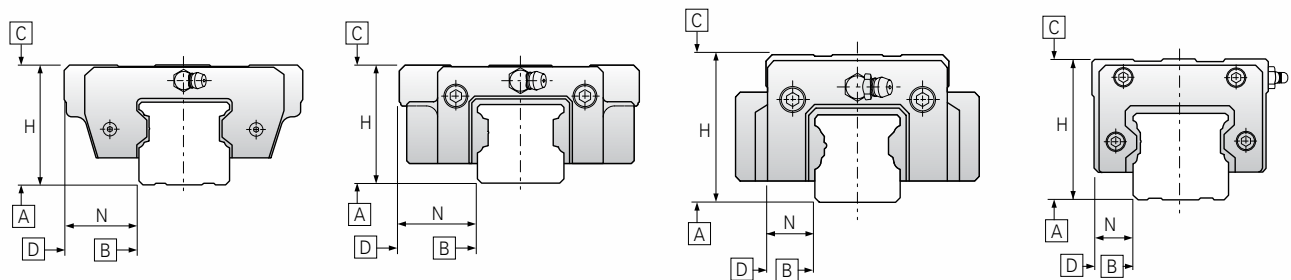

Parallelism of plane **C** to datum plane **A**

Parallelism of plane **D** to datum plane **B**

PARALLELISM

Rail Accuracy Grade		CO01 Ultra Precision (µm)	CO1 Super Precision (µm)	C1 Precision (µm)	C3 High Precision (µm)	C5* Standard Precision (µm)	C7 Commercial Precision (µm)
Min (mm)	Max (mm)						
—	315	1.5	2	2.5	8	16	52
315	400	2	2.5	3.5	10	20	57
400	500	2	3	4.5	11	24	63
500	630	2	3.5	6	14	27	70
630	800	2.5	4	8	16	32	80
800	1,000	3	4.5	9	19	38	90
1,000	1,250	3	6	11	22	43	105
1,250	1,600	4	7	14	25	50	125
1,600	2,000	4.5	8	16	29	57	150
2,000	2,500	6	9	18	30	60	170
2,500	3,150	6	10	18	30	60	210

See unit conversion on page 209.

* Stocked Accuracy-C5



RAIL LENGTH

The maximum lengths of rail for Nook Precision Profile Rails are shown in the table below. Longer lengths can be achieved by butt joining rails.

MAXIMUM LENGTH OF RAIL TRACK

MODEL NO.	MAX. LENGTH
NH-15	3,000
NU-15	1,500
NH-20, 55, 65	3,000
NH-25 thru 45	4,000
NU-20 thru 55	3,000

Unit = mm

RAIL STRAIGHTNESS

To obtain high accuracy guidance, the rail itself must be straight. It is very difficult to mount a distorted rail on a straight mounting surface. Nook rail manufacturing processes ensure straightness for ease of assembly and long life. Distortion free end cuts are achieved through an automated, wet, abrasive cut-off saw system.

PRELOAD & RIGIDITY

For correct operation under complex loading conditions, the selection of a suitable preload for linear motion bearings is essential. For extended life and accuracy under conditions of vibration and shock, the best results are usually achieved by using Nook Precision Profile Rails with heavy preload.

In general, if preload is applied to the Nook Precision Profile Rails, rigidity of the Profile Rail will be doubled compared to that of a non-preloaded Profile Rail.

The preloaded condition is effective for operating loads of up to approximately 3 times the value of preload. Therefore, as a guide, one half to one third of the operating load should be considered for preload and specified according to tables below.

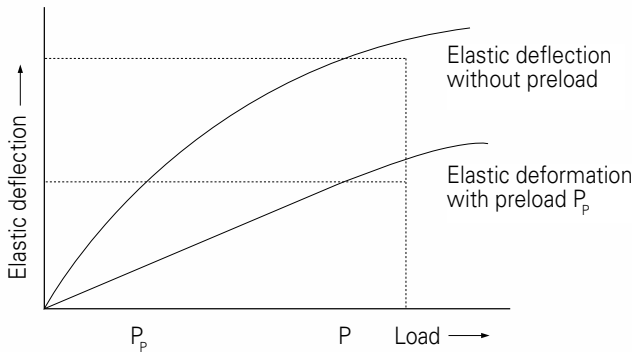

Standard preload (Unit = kgf)

RUNNER BLOCK & STYLE				PRELOAD			
NH-L	NH-NU	NU-SER	T	TO*	T1	T2	T3
		15	—	0	15	30	45
	15	20	—	0	25	50	75
			—	0	30	60	90
	20	25	—	0	40	80	120
25			—	0	50	100	150
	25	30	—	0	55	110	165
30			—	0	70	140	210
	30	35	—	0	80	160	240
			—	0	95	190	285
	35		—	0	110	220	330
			—	0	120	240	360
35			—	0	135	270	405
	45		—	0	180	360	540
45			—	0	210	420	630
	55		—	0	270	540	810
55			—	0	310	620	930
	65		—	0	420	840	1,260
65			—	0	520	1,040	1,560

* Stocked Preload-TO

See unit conversion on page 209.

SELECTION OF PRELOAD

Preload	Conditions of use	Application
T3 Heavy T2 Medium	Heavy cutting or forming work with heavy impact and vibration. Overhung load or alternate load applied.	<ul style="list-style-type: none"> • Machining center • Milling machines • Vertical axis of machine tools
T2 Medium T1 Light	Medium cutting or forming light work with medium impact and vibration. Light overhung load or alternate load applied.	<ul style="list-style-type: none"> • Electrical discharge machines • Surface grinding machines • Robots. • Jig grinding machines • Laser processing machines • Printed circuit board drilling machines • High speed punching machines
T1 Light TO Very Light	Precise movement with very light vibration No overhung load or no measuring equipment alternate load applied.	<ul style="list-style-type: none"> • Precision positioning tables • Automatic tool changer for machining centers • Welding machines • Material feeding devices
TO Very Light T Clearance	Extreme changes in temperature. High precision not required.	<ul style="list-style-type: none"> • Tool changers • Material feeding devices • Plasma cutting machines

LIFE

All of the following factors should be taken into consideration when selecting a Nook Precision Profile Rail System:

The rolling elements and raceways of a Rail System that supports a load are always subject to cyclic stress. Eventually, part of the raceway may spall due to metal fatigue. The life of a linear motion system is defined as the total distance of the travel reached by the time that first fatigue spalling occurs, either from a rolling element or raceway.

DEFINITION OF RATED LOAD

• Dynamic load ratings C

C (kN) is the operating load which specifies 50km of travel.
(1 kgf=9.81 Newtons=0.2248 lbf)

• Static load ratings C₀

C₀ (kN) is the load that causes a permanent deformation equal to 1/10000 of the ball diameter at the contact point between the ball groove and the steel ball.

• Static moment ratings M

M (kN·m) is the moment which causes a permanent deformation equal to 1/10000 of the ball diameter at the contact point between the ball groove and the steel ball when a moment load is applied.

For C, C₀, M of each model refer to dimensional table.

Nook Precision Profile Rails have the same dynamic load capacity in all four directions.

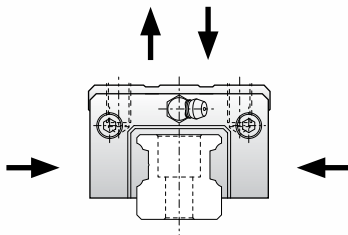

STATIC SAFETY FACTOR

Generally, the maximum permitted static load on the runner block is equivalent to static load ratings C₀. However, in repeated linear motion applications, unexpected load is caused by the inertia when the system starts or stops. Therefore, the safety factor f_s should be calculated in order to determine the allowable load.

$$\frac{C_0}{P_0} \geq f_s$$

Where:

C₀ = static load ratings

P₀ = equivalent load (static load, impact load)

f_s = static safety factor

The value of f_s for general use is indicated in the table.

STATIC SAFETY FACTOR

OPERATING CONDITION	Minimum f _s
Normal operation	1~3
Smooth running required	3~4
Operation with impact or vibration	4~5

DETERMINATION OF RATED FATIGUE LIFE

Dynamic load ratings C (kN), number of strokes per minute and rated fatigue life L (km) are related as follows:

$$L = 50 \times \left(\frac{C}{P}\right)^3$$

Where:

L = expected life

C = basic load ratings

P = equivalent load

Where the stroke s (m) and the number of cycles per minute n₁ (cpm) are constant, the rated fatigue life L_h (hr) is calculated by the following formula.

$$L_h = \frac{50 \times 10^3}{120 \times l_s \times n_1} \times \left(\frac{C}{P}\right)^3$$

Where:

L_h = expected Life (hr)

l_s = stroke length (m)

n₁ = number of strokes per minute

CALCULATION OF RUNNER BLOCK LOAD

• Driving factor and contact factor

The load acting upon the runner block is the sum of all of the loads applied, such as the weight of the table, the cutting force and the inertia force caused by the change of speed or by heavy impact or vibration.

Loads other than the weight of the table are often difficult to calculate. If in doubt, the applied load should be multiplied by a driving factor f_d (table below) to give the effective external load.

DRIVING FACTOR F_d

OPERATING CONDITION	f_d
Smooth running without impact. Speed under 15 m/min.	1.0 ~ 1.5
Running with light impact. Speed under 60 m/min.	1.5 ~ 2.0
Running with heavy impact. Speed over 60 m/min.	2.0 ~ 4.0

In most installations each rail is fitted with at least two runner blocks. The distribution of load across each runner block is very much influenced by the mounting accuracy or machining accuracy of the table. Therefore, the contact factor in the table below should be taken into account. Multiply the load by this factor.

CONTACT FACTOR F_c

Number of runner blocks on one rail	f_c
1	1.00
2	0.86
3	0.74
4	0.66

• Effect of preload on internal load of runner block

Internal load P_A is determined by external force F and preload of runner block P_{PL} .

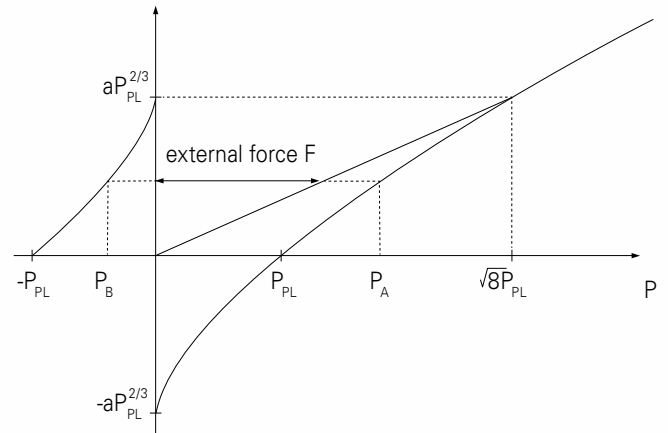

- 1) Where $F \geq \sqrt{8} P_{PL}$
internal load $P_A = \left(\frac{F}{\sqrt{8} P_{PL}} + 1 \right)$
- 2) Where $F > \sqrt{8} P_{PL}$
internal load $P_A = F$

• Resultant force of vertical load and horizontal load

Resultant force of vertical load P_v and horizontal load P_H is determined as follows:

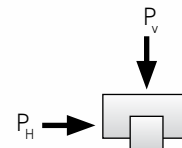

• Resultant force of radial load and moment load

Resultant force of radial load F and moment load M is determined as follows.

$$P = F + M \times \frac{C_0}{M_0}$$

Where:

C_0 = rated static load

M_0 = rated static torque on M direction

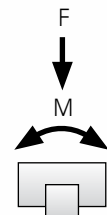

See unit conversion on page 209.

LIFE

• Mean load vs. load variation

In applications where the load on to the runner block varies, mean load should be considered instead of discrete load variations $P_1, P_2 \dots P_n$.

1. For cases where the load and travel vary gradually:

$$P_e = \sqrt[3]{\frac{1}{L} (P_1^3 L_1 + P_2^3 L_2 + \dots + P_n^3 L_n)}$$

Where:

P_e = mean load (kN)

P_n = load step (kN)

L = total travel (m)

L_n = distance travelled by P_n (m)

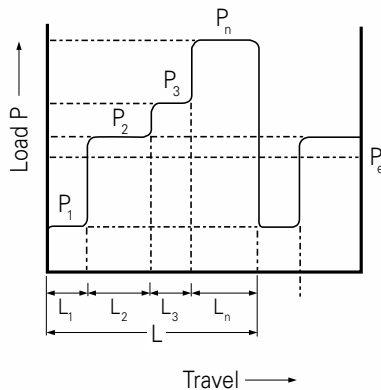

2. For cases where the load vary abruptly:

$$P_e = \frac{2P_{max} + P_{min}}{3}$$

Where:

P_{min} = min. load (kN)

P_{max} = max. load (kN)

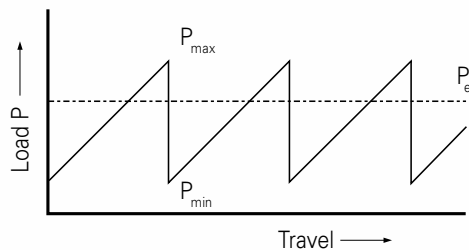

SINUSOIDAL LOAD CHANGE:

$$P_e \approx 0.65 P_{max} \text{ (FIG. A)}$$

$$P_e \approx 0.75 P_{max} \text{ (FIG. B)}$$

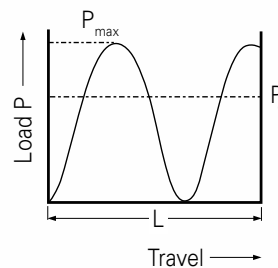

FIG. A

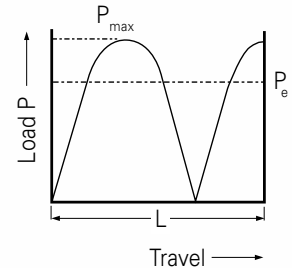

FIG. B

• Frictional resistance

For correct load calculation, frictional resistance of the runner block must be included. Frictional resistance is calculated using the following formula.

$$F = \mu W + f$$

Where:

F = Frictional resistance force (kN)

W = Slide load (kN)

μ = Coefficient of friction

f = Seal resistance force (kN)

The coefficient of friction for Nook Precision Profile Rails is typically 0.003~0.005 with no preload. Seal resistance force per runner block is typically 0.00196~0.002942 kN.

Example: For a mass load (W) of 15.69 kN on 4 runner blocks of NH-TR model, the frictional resistance (F) is calculated:

$$F = \mu W + f \\ = (0.004 \times 15.69) + (0.3 \times 4) = .0745 \text{ kN}$$

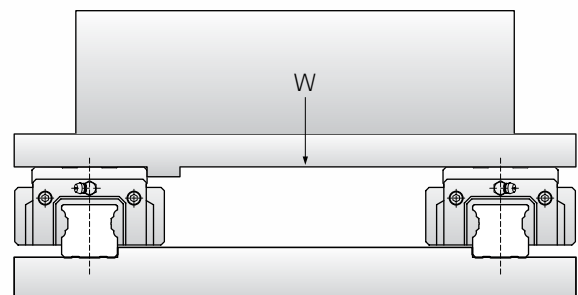

• Load on the runner block

The loads acting on a linear motion system vary according to the location of the center of gravity, the thrust, position, moment, loading speed changes by acceleration and deceleration, cutting forces and other external forces.

It is important that all of these parameters are considered at the design stage.

HORIZONTAL AXIS

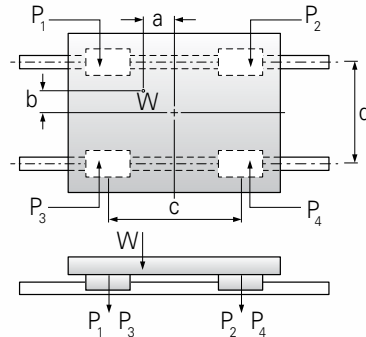

$$P_1 = \frac{1}{4} W + \frac{a}{2c} W + \frac{b}{2d} W$$

$$P_2 = \frac{1}{4} W - \frac{a}{2c} W + \frac{b}{2d} W$$

$$P_3 = \frac{1}{4} W + \frac{a}{2c} W - \frac{b}{2d} W$$

$$P_4 = \frac{1}{4} W - \frac{a}{2c} W - \frac{b}{2d} W$$

PERPENDICULAR HORIZONTAL AXIS

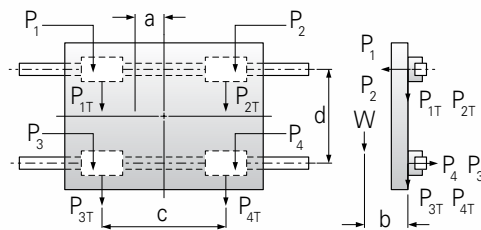

$$P_1 = P_2 = P_3 = P_4 = \frac{b}{2d} W$$

$$P_{1T} = P_{3T} = \frac{1}{4} W + \frac{a}{2c} W$$

$$P_{2T} = P_{4T} = \frac{1}{4} W - \frac{a}{2c} W$$

VERTICAL AXIS

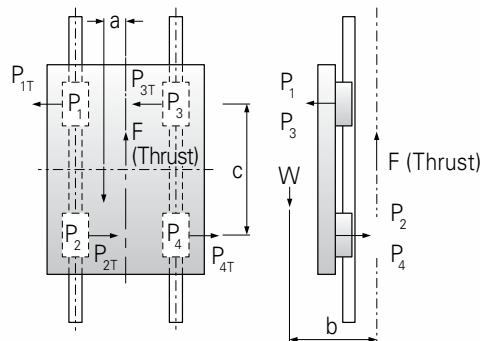

$$P_{1T} = P_{2T} = P_{3T} = P_{4T} = \frac{b}{2c} W$$

$$P_1 = P_2 = P_3 = P_4 = \frac{a}{2c} W$$

ACCELERATION DECELERATION

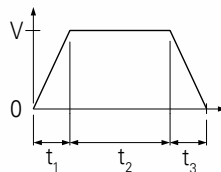
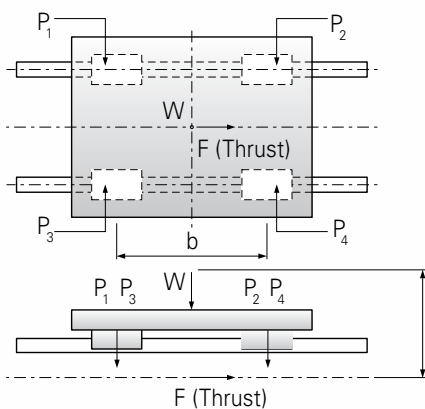

$$P_1 = P_3 = \frac{1}{4} W + \frac{a}{2b} \frac{v}{gt_1} W$$

• While accelerating

$$P_2 = P_4 = \frac{1}{4} W - \frac{a}{2b} \frac{v}{gt_1} W$$

$$P_1 = P_2 = P_3 = P_4 = \frac{1}{4} W$$

• While at a steady-state speed

$$P_1 = P_3 = \frac{1}{4} W - \frac{a}{2b} \frac{v}{gt_3} W$$

• While decelerating

$$P_2 = P_4 = \frac{1}{4} W + \frac{a}{2b} \frac{v}{gt_3} W$$

g: Gravitational Constant = 9.81 m/s²

CALCULATION EXAMPLE

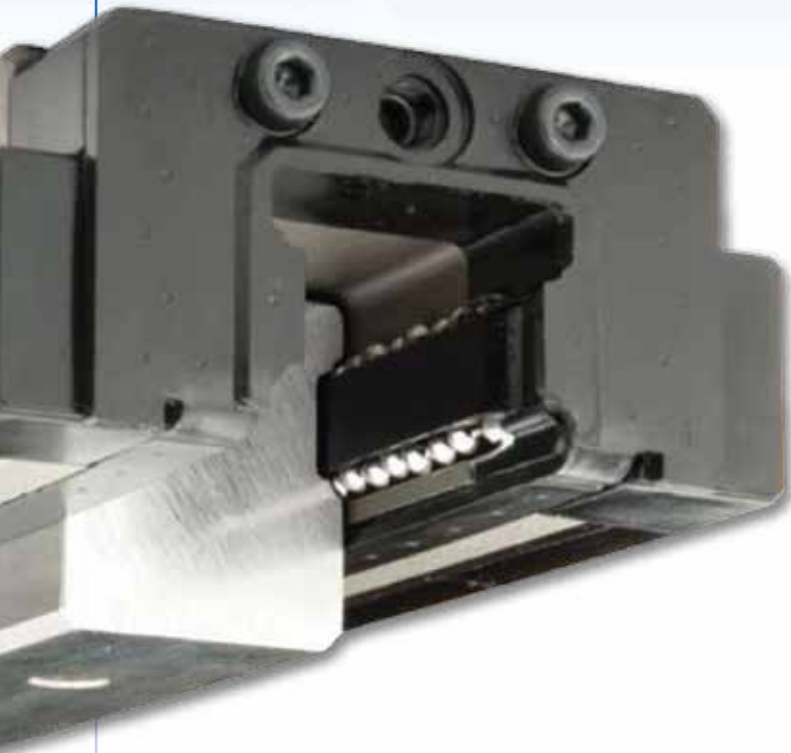

• Determination of runner block life

A sample calculation of runner block life is shown below.

Model NH35TR	Contact factor, $f_c = 0.86$
Stroke, $l_s = 1\text{m}$	2 rails, 4 runner blocks
Load, $W = 9.8\text{ kN}$	No. of cycles, $n_1 = 5\text{ cpm}$
Driving factor, $f_d = 1.2$	

$$P_1 = \frac{f_d}{f_c} \left(\frac{W}{4} - \frac{100W}{2 \times 800} + \frac{200W}{2 \times 1200} \right) = 2.65\text{kN}$$

$$P_2 = \frac{f_d}{f_c} \left(\frac{W}{4} - \frac{100W}{2 \times 800} + \frac{200W}{2 \times 1200} \right) = 3.88\text{kN}$$

$$P_3 = \frac{f_d}{f_c} \left(\frac{W}{4} - \frac{100W}{2 \times 800} + \frac{200W}{2 \times 1200} \right) = 1.02\text{kN}$$

$$P_4 = \frac{f_d}{f_c} \left(\frac{W}{4} - \frac{100W}{2 \times 800} + \frac{200W}{2 \times 1200} \right) = 2.24\text{kN}$$

Life of the No.2 runner block which experiences the highest load is determined from $C=37.55\text{ kN}$ obtained from the dimension table (page 38).

$$L = 50 \times \left(\frac{37.55}{3.88} \right)^3 = 45,321\text{kN}$$

The life in hours can be calculated:

$$L_h = \frac{L \times 10^3}{120 \times l_s \times n_1} = 75,535\text{kN}$$

See unit conversion on page 209.

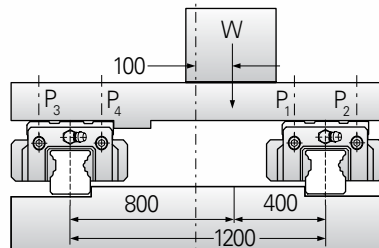
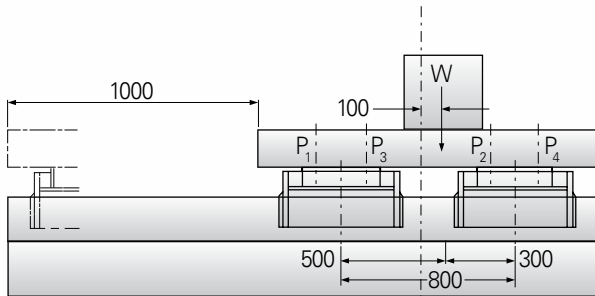

• **Selection of a suitable Profile Rail Assembly as a function of required life**

A sample selection is shown below using the following criteria:

Stroke	$l_s = 1\text{m}$
No. of strokes per minute	$n_1 = 5\text{ cpm (10m/min)}$
Expected life	$L_h = 25000\text{ hr}$
Load	$W = 19.61\text{ kN}$
Driving factor	$f_d = 1.5$
Contact factor from (1) (2)	$f_c = 0.86$

$$L = \frac{120 \times l_s \times n_1}{10^3} \times L_h = \frac{120 \times 1 \times 5}{10^3} \times 25,000 = \text{km}$$

Load per bearing

$$P = \frac{f_d}{f_c} \times \frac{W}{4} = \frac{1.5}{0.86} \times \frac{19.61}{4} = 8.55\text{kN}$$

from equation (1)

$$C = P \times \sqrt[3]{\frac{L}{50}} = 8.55 \times \sqrt[3]{\frac{15,000}{50}} = 57.24\text{kN}$$

NH45TR (C=60.20 kN) which has the required dynamic load rating is selected from the dimension table (page 38).

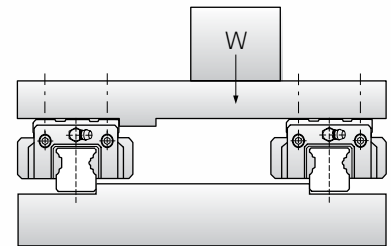
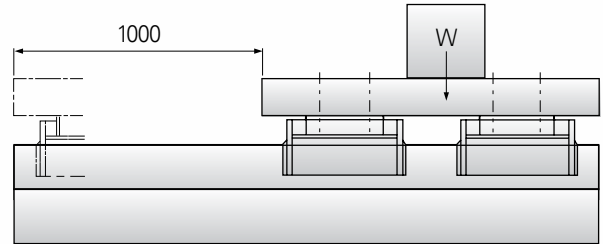

• **Determination of runner block life (single axis)**

A sample selection is shown below using the following criteria:

Model NH35TR	
Rated dynamic load capacity	$C = 37.55\text{ kN}$
Rated static load capacity	$C_0 = 62.55\text{ kN}$
Load	$W = 1.96\text{ kN}$
External force	$F = .196\text{ kN}$
Driving factor	$f_d = 1.4$

$$P_1 = \frac{W}{1} + \frac{F}{2} + \frac{F \times 250}{200} + \frac{F \times 150 \times C_0}{2 \times M_c \times 10^3} = 3.11\text{kN}$$

$$P_2 = \frac{W}{2} + \frac{F}{2} + \frac{F \times 250}{200} + \frac{F \times 150 \times C_0}{2 \times M_c \times 10^3} = 2.13\text{kN}$$

Life of runner block (L) which is subjected to load P_1 is:

$$L = 50 \times \left(\frac{C}{P_1 \times f_d} \right)^3 = 32,070\text{kN}$$

See unit conversion on page 209.

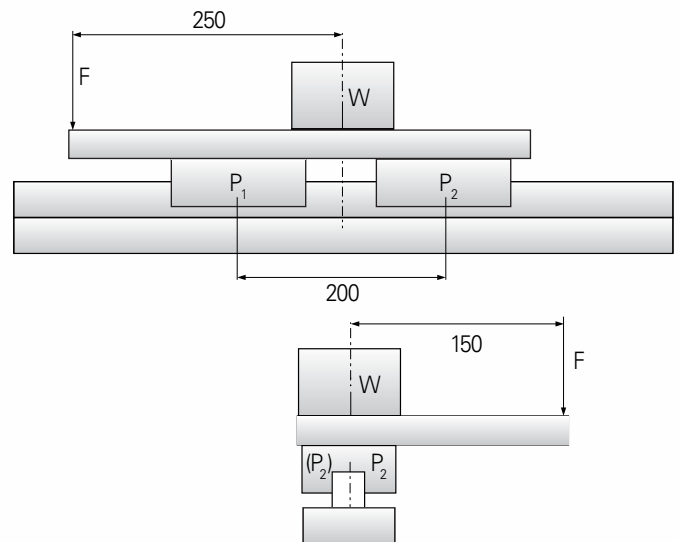

DESIGN RECOMMENDATIONS & GUIDELINES

MOUNTING SHOULDER HEIGHT AND CORNER FILLET

In order to provide a register to align the rail or the runner blocks, mounting surfaces should be machined according to the diagram below with shoulder height and corner radii dimensions as shown in the accompanying table.

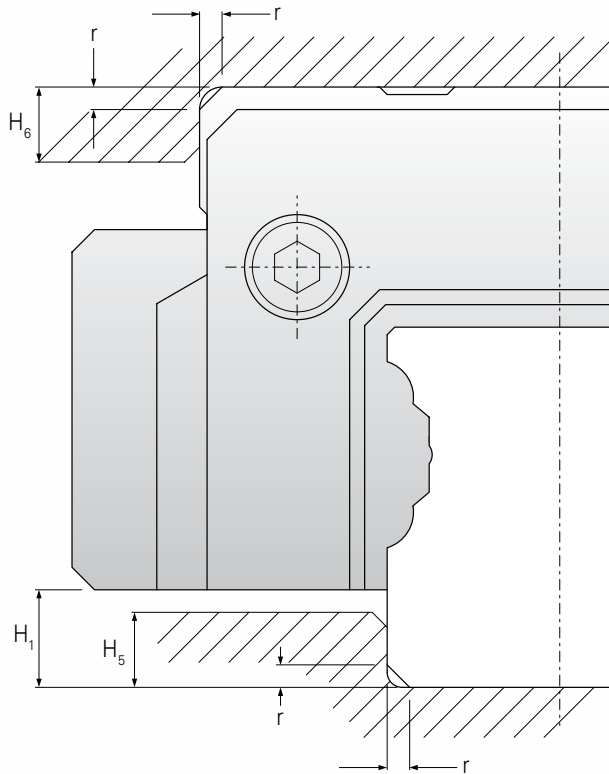

MOUNTING SHOULDER HEIGHT AND CORNER FILLET

Unit = mm

MODEL NO.	CORNER RADIUS R (MAX)	RAIL TRACK SHOULDER HEIGHT H_5	SLIDE UNIT SHOULDER HEIGHT H_6	H_1
NH-15	0.5	4	4	4.6
NU-15				
NU-20	0.5	3	4	4
NH-20				
NU-25	0.5	3	5	4
NH-25				
NH-30	0.5	5	5	6.5
NH-30				
NH-35	1.0	6	6	8
NH-35				
NH-45	1.0	8	8	11
NH-45				
NH-55	1.0	9	0	12
NH-55				
NH-55	1.0	10	10	14
NH-65				

INDICATION OF REFERENCE EDGE

Nook Precision Profile Rails have a reference edge on both the rail and the runner block. See below.

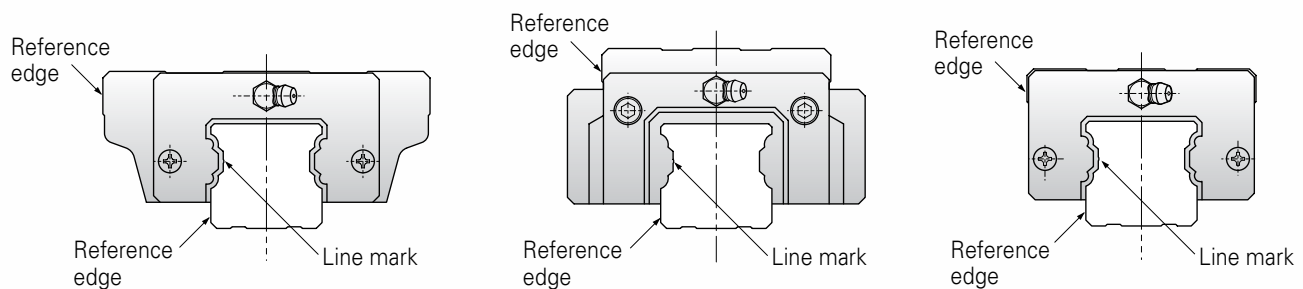

See unit conversion on page 209.

INSTALLATION OF RAIL AND RUNNER BLOCKS

Use any one of the three methods shown below.

The locking set screws should be positioned at the same location as the mounting bolts.

Better alignment is obtained by machining reference edges for both runner block and rail. For optimum performance, the accuracy of the mounting surface should equal that of the rail.

Note: Care should be taken when removing the runner block from the rail to avoid balls deflecting the ball retainers and thus falling out.

1. SET SCREW

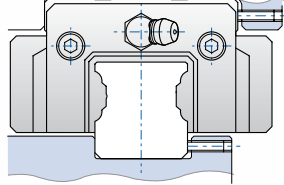
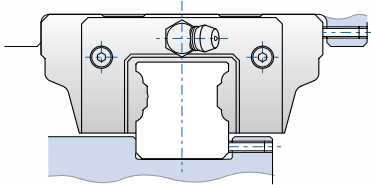

2. CLAMPS

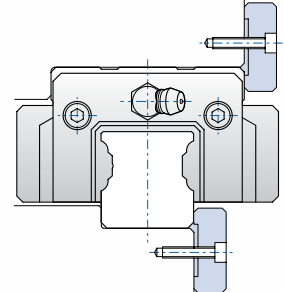
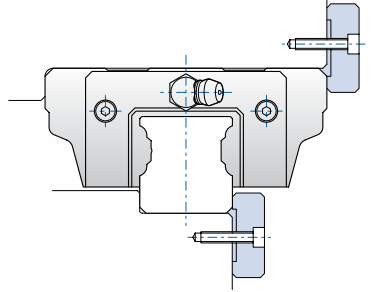

3. TAPERED WEDGES

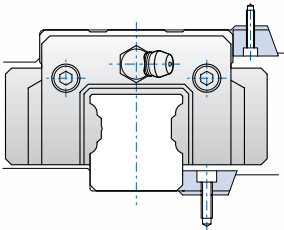
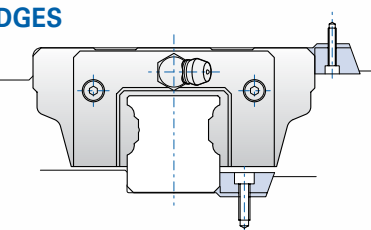

SYSTEM DESIGN CONFIGURATIONS FOR NOOK PRECISION PROFILE RAILS

Shown below are various installations for profile rail systems. One through four are the most common. Five through eight are for limited height applications. Number nine is the least accurate.

	Opposing			
	Horizontal	Vertical	Horizontal	Vertical
Rail Track Fixed	1,9	3	5	7
Runner Block Fixed	2	4	6	8

See examples below: A= Adjustable Side • R= Reference Side

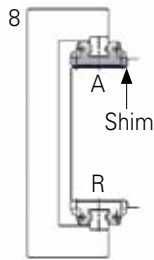
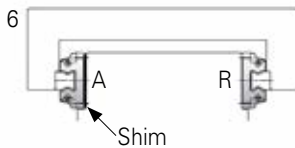
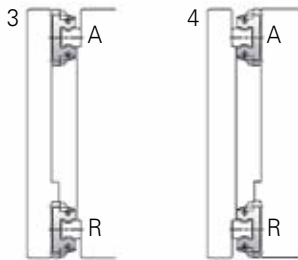
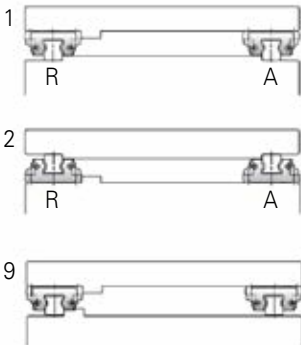

BELLOW COVERS

When additional protection is required, the use of Nook bellows is recommended. The chart below indicates the bellows dimensions. PVC coated nylon material is used exclusively. Neoprene-cloth and chemically resistant materials are also available upon request.

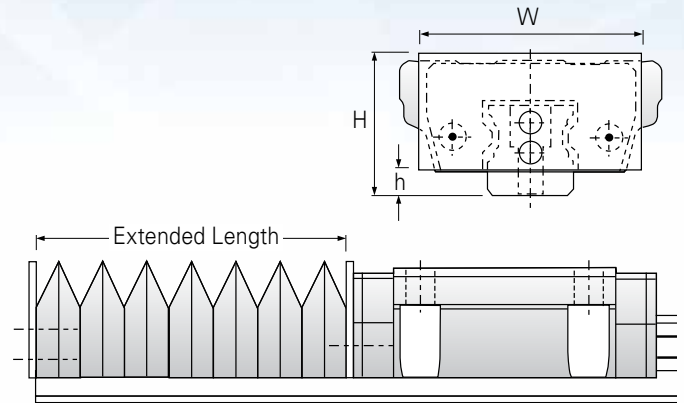

BELLOW MODEL NO.	PROFILE RAIL MODEL NO.	W	H	h	ABOVE OR BELOW BLOCK	L FACTOR
JS15	NH-15 EA	48	24.5	5	Above 6mm	1.28
JS15	NH-15 ER	41	23.5	5	Above 6mm	1.28
JS20	NH-20 EA	51	28	5	Above 3mm	1.28
JS20	NU-20 ER	46	26.4	4	Above 4mm	1.28
JS25	NH-25 EA	51	28	7	Even	1.28
JS25	NU-25 ER	47	28.5	4	Above 1mm	1.28
JS30	NH-30 EA	58	35	7	Even	1.20
JS30	NU-30 ER	60	35	7	Even	1.20
JS35	NH-35 EA	72	40	8	Even	1.17
JS35	NU-35 ER	70	40	8	Even	1.17
JS45	NH-45 EA	83	45	11	Even	1.17
JS45	NU-45 ER	81	47	11	Even	1.17
JS55	NH-55 EA	100	55	14	Even	1.13
JS55	NU-55 ER	100	55	12	Even	1.13
JS65	NH-65 EA	117	68	14	Even	1.11

See unit conversion on page 209.

EXTENDED LENGTH CALCULATIONS

Maximum extended length:

$$\text{Extended}_{\text{max}} = \text{Stroke} \times \text{L Factor}$$

Minimum collapsed length:

$$\text{Collapsed}_{\text{min}} = \text{Extended}_{\text{max}} - \text{Stroke} + 10\text{mm}$$

Add 10mm to bellows compressed length for hardware.

LUBRICATION & SEALING

Proper lubrication and contamination protection are an essential requirement for Nook Precision Profile Rails.

SEAL

A standard feature of Nook runner blocks is a special composite rubber or felt seal that effectively retains grease (lithium soap base) within the runner block.



SCRAPERS

Stainless scraper plate option for enhanced protection of the seal as well as removal of containment build up such as light weld spatter and overspray.



MOUNTING HOLE CAPS

For sealing quality and protection use the cap plugs supplied by Nook to cover the mounting holes in the rail flush with the top surface.



GREASE GUN

Refillable and reusable push style grease gun for lubricating size 15 block. Ships empty to allow for application specific grease.



Part Number - PA-2001-9

GREASE FITTINGS

Lubrication is recommended every six months or after every 100km (about 330,000 ft.) of travel. If lubrication every six months or 100km is not practical, forced oil lubrication is necessary. Refer to the catalog pages for the runner block types to determine the style of grease fitting supplied.

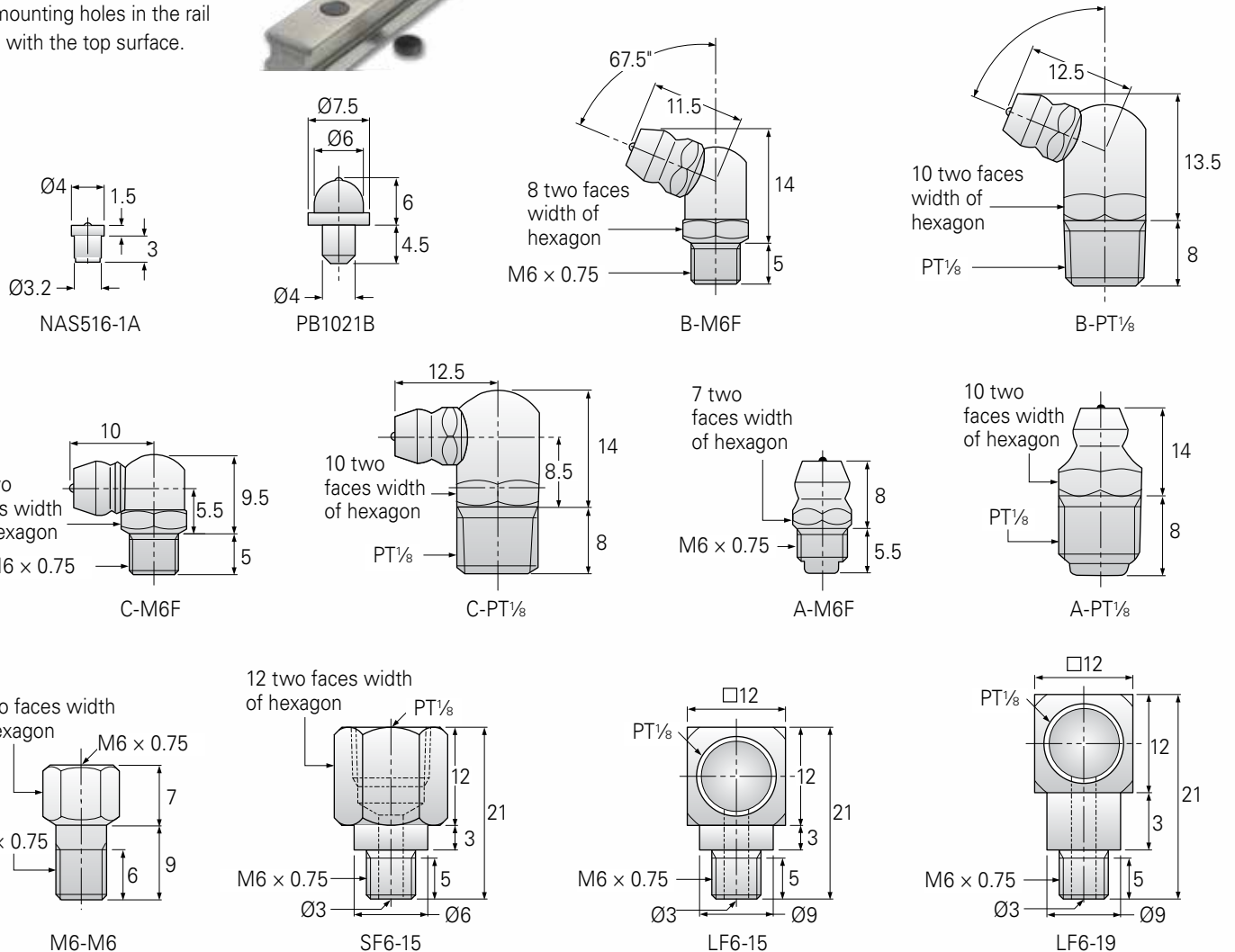

ORIENTATION OF REFERENCE SURFACE AND GREASE FITTING STANDARD POSITION

IN CASE OF L TYPE FITTING:

IN CASE OF I (INTERNAL) TYPE FITTING:

B1W1

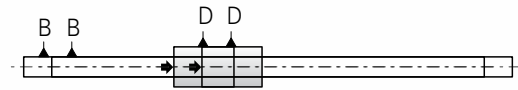
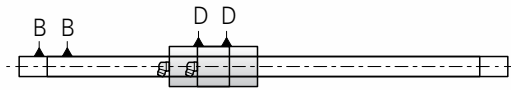

B2W1

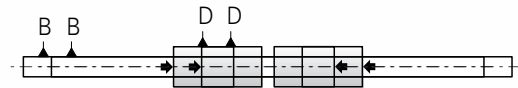
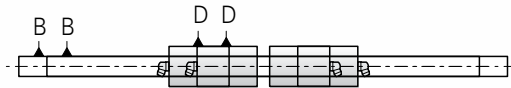

B3W1

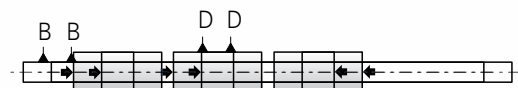
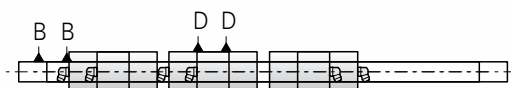

B4W1

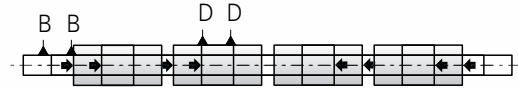
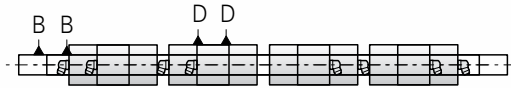

B1W2

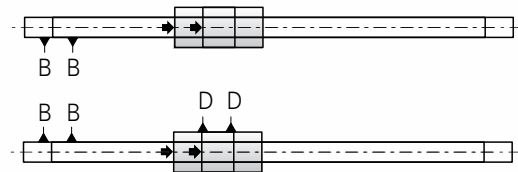
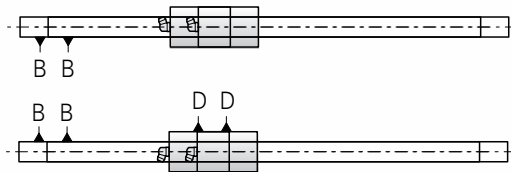

B2W2

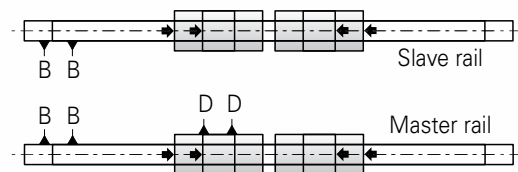
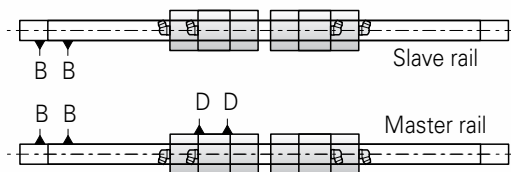

B3W2

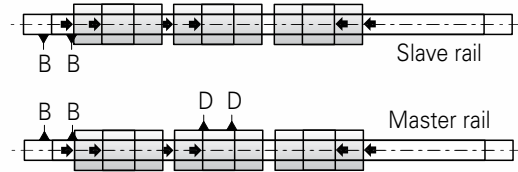
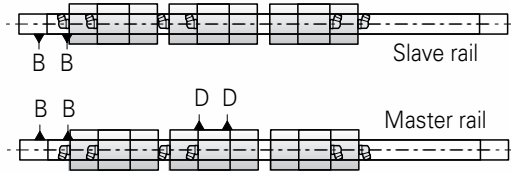

B4W2

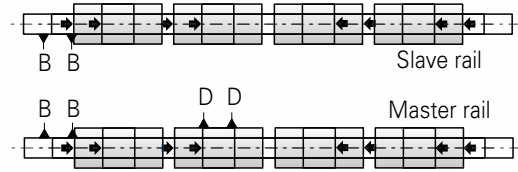
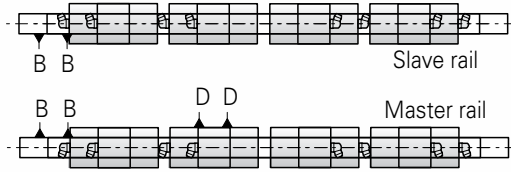

◆ shows direction of feeding

NOOK PRECISION PROFILE BALL RAIL
TECHNICAL DATA

HEAVY LOAD TYPE 24 - 31

- Overview and Features 25
- NH-EA / NH-LEA Series: Heavy Load - Flange-Mount - Four Tapped Holes 26
- NH-EB / NH-LEB Series: Heavy Load - Flange-Mount - Four Thru Holes 28
- NH-ER / NH-LER Series: Heavy Load - Narrow Width - Four Tapped Holes 30



HEAVY LOAD HIGH SPEED TYPE 32 - 39

- Overview and Features 33
- NH-TA / NH-TAH Series: Heavy Load - High Speed - Four Tapped Holes 34
- NH-TB Series: Heavy Load - High Speed - Four Thru Holes 36
- NH-TR Series: Heavy Load - High Speed - Four Tapped Holes 38

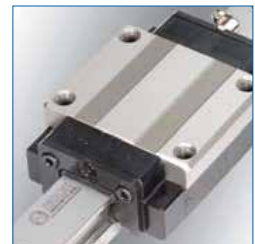

MEDIUM LOAD COMPACT TYPE 40 - 43

- Overview and Features 41
- NU-ER / NU-SER Series: Medium Load - Compact - Two or Four Tapped Holes 42



ORDERING DESIGNATIONS AND FORMS 44 - 47

- Single Guide Rail 44
- Two Guide Rails 45
- Three Guide Rails 46
- Application Data Form 47

REQUEST FOR QUOTATION 198

UNIT CONVERSION 199

English to Metric and Metric to English

HEAVY LOAD TYPE

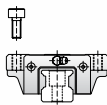
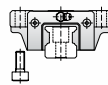
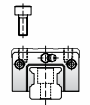
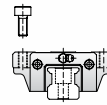
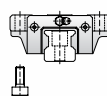
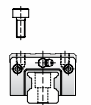

SELECTION OF ULTRA HEAVY AND HEAVY LOAD TYPE

Classification Model Type	Ultra Heavy Load Type			Heavy Load Type		
	NH-LEA	NH-LEB	NH-LER	NH-EA	NH-EB	NH-ER
Mounting Direction						
Main Fetures	Ultra heavy load type with long runner blocks			Flange type heavy load type		Narrow width heavy load type
Permissible Speed (m/min)	120	120	120	120	120	120
Accuracy	C001-C7	C001-C7	C001-C7	C001-C7	C001-C7	C001-C7
Preload	T-T3	T-T3	T-T3	T-T3	T-T3	T-T3
Vibration Behavior	Good	Good	Good	Good	Good	Good
Noise	Low	Low	Low	Low	Low	Low

See unit conversion on page 209.

OVERVIEW & FEATURES

NOOK PROFILE RAIL DESIGN

Nook Ultra Heavy Load Type Runner Blocks maintain circulation of the balls by a retainer and end cap. The four rows of balls on the inner runner block are arranged in two rows on either side facing each other and contacting at a 45° angle. As the load is transmitted the balls contact the rail at two points at an inclusive angle of 90°. In turn, the contact with the outer track is the same, making a square load force configuration.

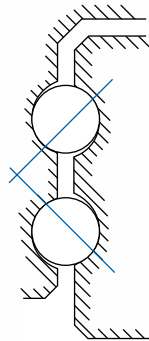

EQUAL LOAD IN FOUR DIRECTIONS

The shape of Nook runner blocks have an equal rated load capacity in any direction. Equal rigidity is therefore obtained in any of the four loading directions making Nook runner blocks ideal for single or combination loads.

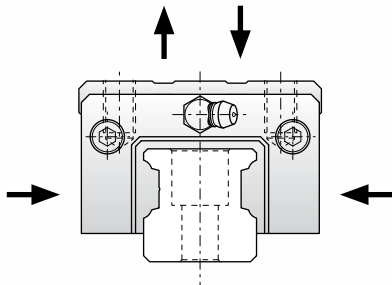

MOUNTING ERROR ABSORPTION AND ROLLING MOMENT RIGIDITY

Nook runner blocks are designed to absorb some of the mounting inaccuracies without any significant increase in the sliding friction.

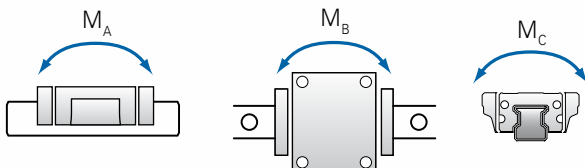

ERROR ALLOWANCE IN THE PARALLELISM BETWEEN TWO RAILS - HORIZONTAL PLANE

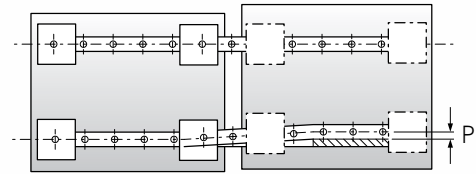

Permissible Tolerance (P) for Parallelism

CLEARANCE

MODEL NH	P		
Model No.	T0	T1	T2-T3
15	—	18	25
20	18	20	25
25	20	22	30
30	27	30	40
35	30	35	50
45	35	40	60
55	45	50	70
65	55	60	80

Unit = μm

ERROR ALLOWANCE BETWEEN TWO RAILS

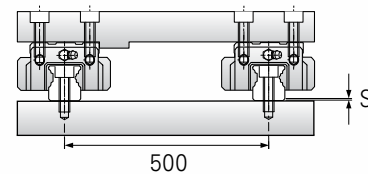

Permissible Tolerance (S) for Two Level

TWO LEVEL OFFSET: The values in the figures show the permissible tolerances for the rail to rail distance of 500 mm. The permissible values are proportional to the rail to rail distances.

CLEARANCE

MODEL NH	S		
Model No.	T0	T1	T2-T3
15	—	85	130
20	50	85	130
25	70	85	130
30	90	110	170
35	120	150	210
45	140	170	250
55	170	210	300
65	200	250	350

Unit = μm

NH-EA • NH-LEA **HEAVY LOAD**
FLANGE-MOUNT
FOUR TAPPED HOLES

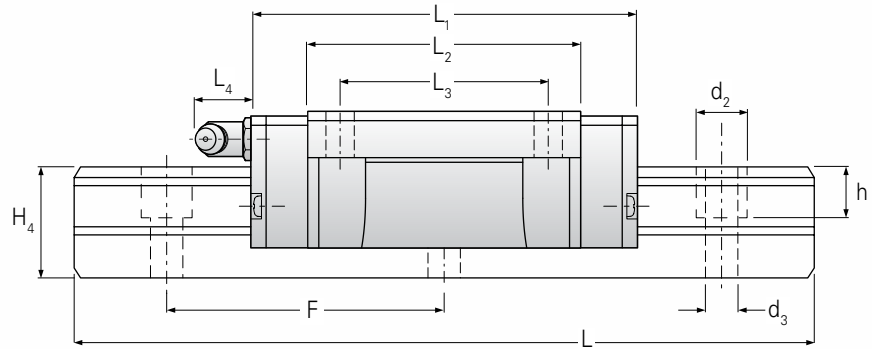

Nook Precision Profile Rail Systems provide stable and efficient linear motion guidance under variable speeds and high load conditions.

- Interchangeable with other manufacturers
- NH-EA provides Heavy Load with Flange
- NH-LEA provides Heavy Load with Long Slide Unit
- Precision Class: C0001 - C7
- Preload: T0 - T3
- Maximum Rail Length:
 NH15: 3000mm
 NH25 thru NH45: 4000mm
 NH55 thru NH65: 3000mm

Model	ASSEMBLY DIMENSIONS			RUNNER BLOCK DIMENSIONS									GREASE FITTING
	Height H	Width W ₁	Length L ₁	W ₂	L ₃	M ₁ *	L ₂	H ₃	L ₄	W ₃	H ₁	N	
NH15EA	24	47	58.5	38	30	M5×7	38.5	7	0	4.5	4.6	16	NAS516-1A
NH20EA	30	63	73	53	40	M6×1	50	8	0	5	5	21.5	NAS516-1A
NH25EA	36	70	83	57	45	M8×10	59	10	12	6.5	6.5	23.5	B-M6F
NH25LEA	36	70	107	57	45	M8×10	83	10	12	6.5	6.5	23.5	B-M6F
NH30EA	42	90	97	72	52	M10×10	68	13	12	9	7	31	B-M6F
NH30LEA	42	90	123	72	52	M10×10	94	13	12	9	7	31	B-M6F
NH35EA	48	100	112	82	62	M10×13	80	13	12	9	8	33	B-M6F
NH35LEA	48	100	141	82	62	M10×13	109	13	12	9	8	33	B-M6F
NH45EA	60	120	139	100	80	M12×15	102	15	14	10	11	37.5	B-PT ¹ / ₈
NH45LEA	60	120	167	100	80	M12×15	130	15	14	10	11	37.5	B-PT ¹ / ₈
NH55EA	70	140	159	116	95	M14×17	124	17	16	12	14	43.5	B-PT ¹ / ₈
NH55LEA	70	140	191	116	95	M14×17	156	17	16	12	14	43.5	B-PT ¹ / ₈
NH65EA	85	170	188	142	110	M16×20	148	20	16	14	14	53.5	B-PT ¹ / ₈
NH65LEA	85	170	247	142	110	M16×20	207	20	16	14	14	53.5	B-PT ¹ / ₈

See unit conversion on page 209.

* Recommended bolt size x minimum bolt length

NH15EA ▶ NH65LEA

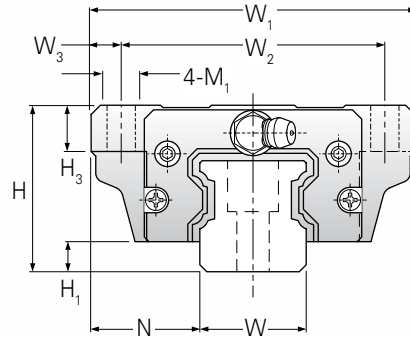

	RAIL DIMENSIONS				BASIC LOAD RATINGS				STATIC MOMENT RATINGS						WEIGHT	
	Height H_4	Width W	Pitch F	Mount $d_3 \times d_2 \times h$	Dynamic C		Static C_0								Block kg	Rail kg/m
					kN	lb	kN	lb	kN-m	lb-in	kN-m	lb-in	kN-m	lb-in		
	17	15	60	4.5 × 7.5 × 7	8.43	1,896	13.53	3,041	0.07	608	0.07	608	0.13	1,128	0.19	1.7
	21	20	60	6 × 9.5 × 11	13.92	3,130	23.83	5,157	0.16	1,389	0.16	1,389	0.26	2,344	0.4	2.8
	24	23	60	7 × 11 × 11	20.00	4,496	34.42	7,736	0.27	2,430	0.27	2,430	0.44	3,906	0.69	3.7
	24	23	60	7 × 11 × 11	27.36	6,149	45.89	10,314	0.47	4,166	0.47	4,166	0.64	5,642	0.97	3.7
	28	28	80	9 × 14 × 14	28.24	6,347	46.87	10,535	0.43	3,819	0.43	3,819	0.72	6,336	1.8	5.3
	28	28	80	9 × 14 × 14	37.55	8,441	62.56	14,061	0.73	6,423	0.73	6,423	0.98	8,680	1.8	5.3
	32	34	80	9 × 14 × 15	37.55	8,441	62.56	14,061	0.64	5,642	0.64	5,642	1.13	9,982	1.8	7.5
	32	34	80	9 × 14 × 15	50.30	11,306	81.59	18,337	1.13	9,982	1.13	9,982	1.64	14,496	2.5	7.5
	42	45	105	14 × 20 × 21	60.21	13,532	95.71	21,510	1.30	11,544	1.30	11,544	2.30	20,398	3.1	12.9
	42	45	105	14 × 20 × 21	80.61	18,116	127.48	28,651	2.11	18,662	2.11	18,662	3.13	27,689	4.0	12.9
	48	53	120	16 × 23 × 24	90.02	20,232	137.09	30,811	2.22	19,617	2.22	19,617	4.16	37,671	5.1	17.3
	48	53	120	16 × 23 × 24	119.05	26,756	183.09	41,147	3.17	32,810	3.17	32,810	5.31	47,046	6.5	17.3
	58	63	150	18 × 26 × 25	141.11	31,714	215.15	48,354	4.21	37,237	4.21	37,237	7.38	65,360	9.1	24.9
	58	63	150	18 × 26 × 25	192.11	43,175	286.15	64,310	7.21	63,798	7.21	63,798	10.75	95,133	13.1	24.9

NH-EB • NH-LEB **HEAVY LOAD**
FLANGE-MOUNT
FOUR THRU HOLES

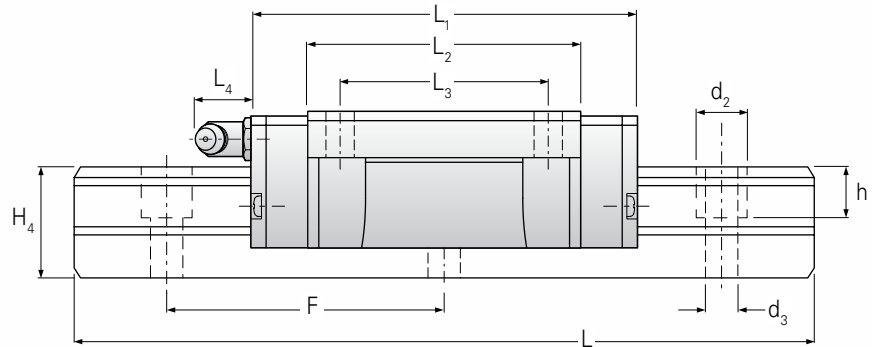

Nook Precision Profile Rail Systems provide stable and efficient linear motion guidance under variable speeds and high load conditions.

- Interchangeable with other manufacturers
- NH-EB provides Heavy Load with Flange
- NH-LEB provides Heavy Load with Long Slide Unit
- Precision Class: C0001 - C7
- Preload: T0 - T3
- Maximum Rail Length:
NH15: 3000mm
NH25 thru NH45: 4000mm
NH55 thru NH65: 3000mm

Model	ASSEMBLY DIMENSIONS			RUNNER BLOCK DIMENSIONS									GREASE FITTING
	Height H	Width W ₁	Length L ₁	W ₂	L ₃	M ₁ *	L ₂	H ₃	L ₄	W ₃	H ₁	N	
NH15EB	24	47	58.5	38	30	4.5	38.5	7	0	4.5	4.6	16	NAS516-1A
NH20EB	30	63	73	53	40	6	50	8	0	5	5	21.5	NAS516-1A
NH25EB	36	70	83	57	45	7	59	10	12	6.5	6.5	23.5	B-M6F
NH25LEB	36	70	107	57	45	7	83	10	12	6.5	6.5	23.5	B-M6F
NH30EB	42	90	97	72	52	9	68	13	12	9	7	31	B-M6F
NH30LEB	42	90	123	72	52	9	94	13	12	9	7	31	B-M6F
NH35EA	48	100	112	82	62	9	80	13	12	9	8	33	B-M6F
NH35LEB	48	100	141	82	62	9	109	13	12	9	8	33	B-M6F
NH45EB	60	120	139	100	80	11	102	15	14	10	11	37.5	B-PT ¹ / ₈
NH45LEB	60	120	167	100	80	11	130	15	14	10	11	37.5	B-PT ¹ / ₈
NH55EB	70	140	159	116	95	14	124	17	16	12	14	43.5	B-PT ¹ / ₈
NH55LEB	70	140	191	116	95	14	156	17	16	12	14	43.5	B-PT ¹ / ₈
NH65EB	85	170	188	142	110	16	148	20	16	14	14	53.5	B-PT ¹ / ₈
NH65LEB	85	170	247	142	110	16	207	20	16	14	14	53.5	B-PT ¹ / ₈

See unit conversion on page 209.

* Hole diameter x minimum bolt length

NH15EB ▶ NH65LEB

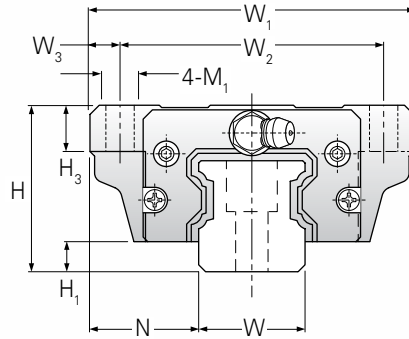

	RAIL DIMENSIONS				BASIC LOAD RATINGS				STATIC MOMENT RATINGS						WEIGHT	
	Height H_4	Width W	Pitch F	Mount $d_3 \times d_2 \times h$	Dynamic C		Static C_0								Block kg	Rail kg/m
					kN	lb	kN	lb	kN·m	lb-in	kN·m	lb-in	kN·m	lb-in		
	17	15	60	4.5 × 7.5 × 7	8.43	1,896	13.53	3,041	0.07	608	0.07	608	0.13	1,128	0.19	1.7
	21	20	60	6 × 9.5 × 11	13.92	3,130	23.83	5,157	0.16	1,389	0.16	1,389	0.26	2,344	0.4	2.8
	24	23	60	7 × 11 × 11	20.00	4,496	34.42	7,736	0.27	2,430	0.27	2,430	0.44	3,906	0.69	3.7
	24	23	60	7 × 11 × 11	27.36	6,149	45.89	10,314	0.47	4,166	0.47	4,166	0.64	5,642	0.97	3.7
	28	28	80	9 × 14 × 14	28.24	6,347	46.87	10,535	0.43	3,819	0.43	3,819	0.72	6,336	1.8	5.3
	28	28	80	9 × 14 × 14	37.55	8,441	62.56	14,061	0.73	6,423	0.73	6,423	0.98	8,680	1.8	5.3
	32	34	80	9 × 14 × 15	37.55	8,441	62.56	14,061	0.64	5,642	0.64	5,642	1.13	9,982	1.8	7.5
	32	34	80	9 × 14 × 15	50.30	11,306	81.59	18,337	1.13	9,982	1.13	9,982	1.64	14,496	2.5	7.5
	42	45	105	14 × 20 × 21	60.21	13,532	95.71	21,510	1.30	11,544	1.30	11,544	2.30	20,398	3.1	12.9
	42	45	105	14 × 20 × 21	80.61	18,116	127.48	28,651	2.11	18,662	2.11	18,662	3.13	27,689	4.0	12.9
	48	53	120	16 × 23 × 24	90.02	20,232	137.09	30,811	2.22	19,617	2.22	19,617	4.16	37,671	5.1	17.3
	48	53	120	16 × 23 × 24	119.05	26,756	183.09	41,147	3.17	32,810	3.17	32,810	5.31	47,046	6.5	17.3
	58	63	150	18 × 26 × 25	141.11	31,714	215.15	48,354	4.21	37,237	4.21	37,237	7.38	65,360	9.1	24.9
	58	63	150	18 × 26 × 25	192.11	43,175	286.15	64,310	7.21	63,798	7.21	63,798	10.75	95,133	13.1	24.9

NH-ER • NH-LER **HEAVY LOAD**
FLANGE-MOUNT
FOUR TAPPED HOLES

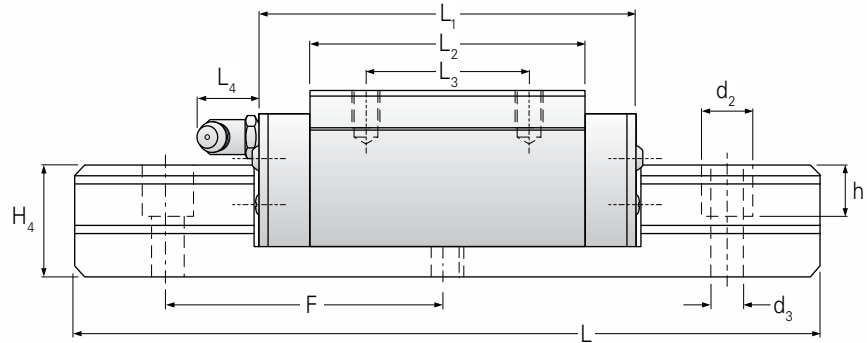

Nook Precision Profile Rail Systems provide stable and efficient linear motion guidance under variable speeds and high load conditions.

- Interchangeable with other manufacturers
- NH-ER provides Heavy Load with Narrow width
- NH-LER provides Heavy Load with Long Slide Unit
- Precision Class: C0001 - C7
- Preload: T0 - T3
- Maximum Rail Length:
 NH15: 3000mm
 NH25 thru NH45: 3000mm
 NH55 thru NH65: 3000mm

Model	ASSEMBLY DIMENSIONS			RUNNER BLOCK DIMENSIONS									GREASE FITTING
	Height H	Width W ₁	Length L ₁	W ₂	L ₃	M ₁ *	L ₂	H ₃	L ₄	W ₃	H ₁	N	
NH15ER	28	34	59	26	26	M4 × 5	38.5	6	0	4	4.5	9.5	NAS516-1A
NH20ER	30	44	73	32	36	M5 × 6	50	8	0	6	5	12	NAS516-1A
NH25ER	40	48	83	35	35	M6 × 8	59	8	12	6.5	6.5	12.5	NAS516-1A
NH25LER	40	48	107	35	50	M6 × 8	83	8	12	6.5	6.5	12.5	B-M6F
NH30ER	45	60	97	40	40	M8 × 10	68	8	12	10	7	16	B-M6F
NH30LER	45	60	123	40	60	M8 × 10	94	8	12	10	7	16	B-M6F
NH35ER	55	70	112	50	50	M8 × 12	80	10	12	10	8	18	B-M6F
NH35LER	55	70	141	50	72	M8 × 12	109	10	12	10	8	18	B-M6F
NH45ER	70	86	139	60	60	M10 × 17	102	15	16	13	11	20.5	B-M6F
NH45LER	70	86	167	60	80	M10 × 17	130	15	16	13	11	20.5	B-PT ¹ / ₈
NH55ER	80	100	168	75	75	M12 × 18	124	18	16	12.5	14	23.5	B-PT ¹ / ₈
NH55LER	80	100	200	75	95	M12 × 18	156	18	16	12.5	14	23.5	B-PT ¹ / ₈
NH65ER	90	126	198	90	70	M16 × 20	148	23	16	18	14	31.5	B-PT ¹ / ₈
NH65LER	90	126	257	90	120	M16 × 20	207	23	16	18	14	31.5	B-PT ¹ / ₈

See unit conversion on page 209.

* Recommended bolt size × minimum bolt length

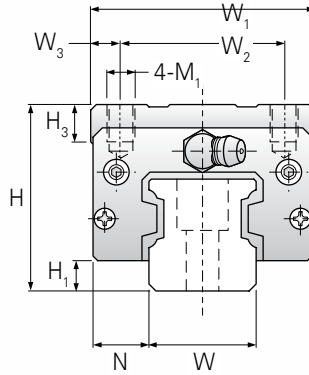

NH20ER ▶ NH65LER

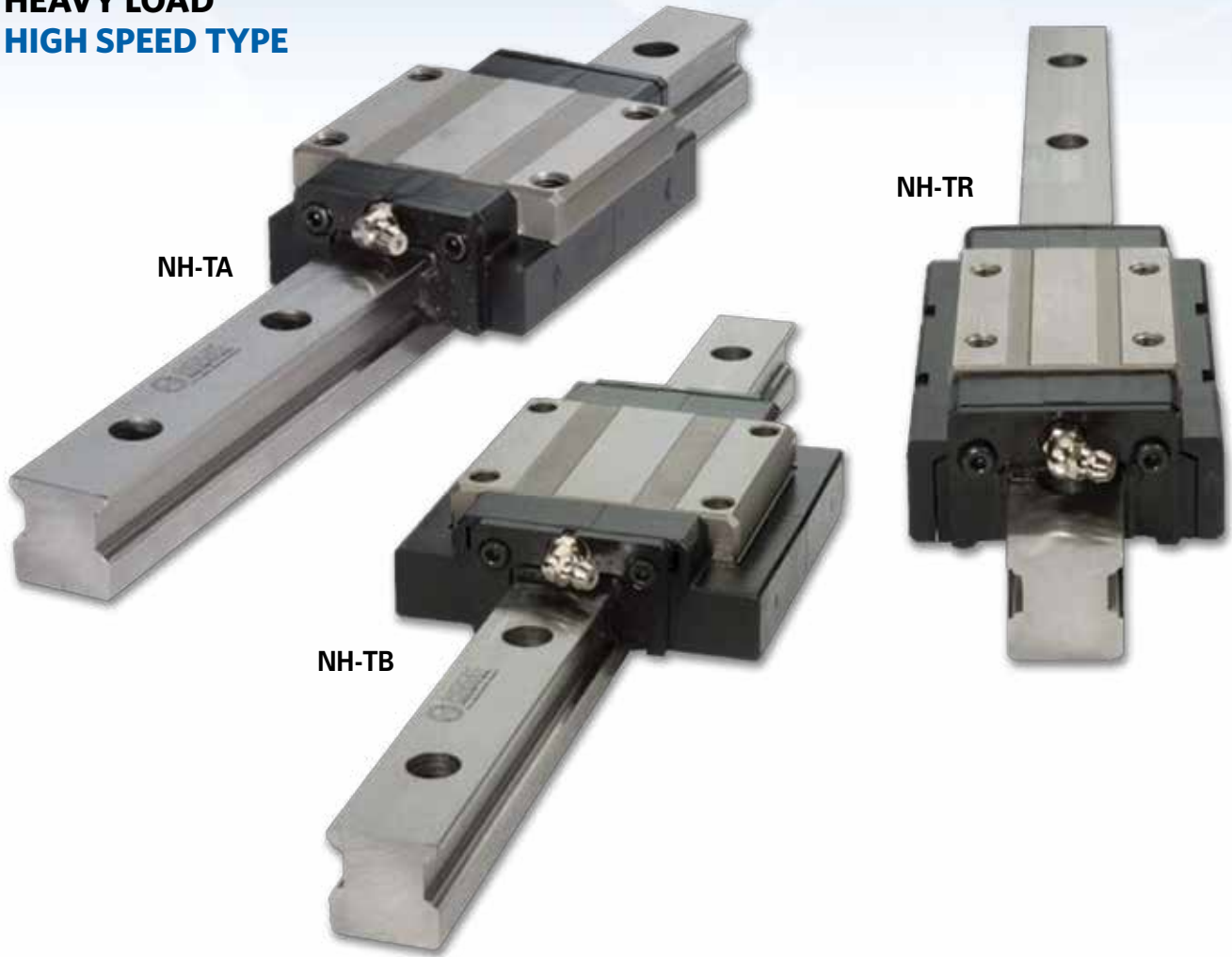

	RAIL DIMENSIONS				BASIC LOAD RATINGS				STATIC MOMENT RATINGS						WEIGHT	
	Height	Width	Pitch	Mount	Dynamic C		Static C_0		M_A		M_B		M_C		Block	Rail
	H_4	W	F	$d_3 \times d_2 \times h$	kN	lb	kN	lb	kN-m	lb-in	kN-m	lb-in	kN-m	lb-in	kg	kg/m
	17	15	60	7.5 × 4.5 × 7	8.82	1,982	17.02	3,826	0.12	1,036	0.12	1,036	0.18	1,523	0.20	1.7
	21	20	60	6 × 9.5 × 11	13.92	3,130	23.83	5,157	0.16	1,389	0.16	1,389	0.26	2,344	0.29	2.8
	24	23	60	7 × 11 × 11	20.00	4,496	34.42	7,736	0.27	2,430	0.27	2,430	0.44	3,906	0.57	3.7
	24	23	60	7 × 11 × 11	27.36	6,149	45.89	10,314	0.47	4,166	0.47	4,166	0.64	5,642	0.8	3.7
	28	28	80	9 × 14 × 14	28.24	6,347	46.87	10,535	0.43	3,819	0.43	3,819	0.72	6,336	0.99	5.3
	28	28	80	9 × 14 × 14	37.55	8,441	62.56	14,061	0.73	6,423	0.73	6,423	0.98	8,680	1.4	5.3
	32	34	80	9 × 14 × 15	37.55	8,441	62.56	14,061	0.64	5,642	0.64	5,642	1.13	9,982	1.6	7.5
	32	34	80	9 × 14 × 15	50.30	11,306	81.59	18,337	1.13	9,982	1.13	9,982	1.64	14,496	2.2	7.5
	42	45	105	14 × 20 × 21	60.21	13,532	95.71	21,510	1.30	11,544	1.30	11,544	2.30	20,398	2.9	12.9
	42	45	105	14 × 20 × 21	80.61	18,116	127.48	28,651	2.11	18,662	2.11	18,662	3.13	27,689	3.7	12.9
	48	53	120	16 × 23 × 24	90.02	20,232	137.09	30,811	2.22	19,617	2.22	19,617	4.16	37,671	4.5	17.3
	48	53	120	16 × 23 × 24	119.05	26,756	183.09	41,147	3.17	32,810	3.17	32,810	5.31	47,046	5.8	17.3
	58	53	150	18 × 26 × 25	141.11	31,714	215.16	48,354	4.21	37,237	4.21	37,237	7.38	65,360	7.2	24.9
	58	63	150	18 × 26 × 25	192.11	43,175	286.15	64,310	7.21	63,798	7.21	63,798	10.75	95,133	10.5	24.9

HEAVY LOAD HIGH SPEED TYPE

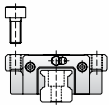
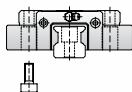

CLASSIFICATION	HEAVY LOAD TYPE-GREATER PERMISSIBLE SPEED		
	Model Type	NH-TA	NH-TB
Mounting Direction			
Main Features	Heavy Load Type-Greater Permissible Speed		
Permissible speed (m/min)	120	120	120
Accuracy	C001-C7	C001-C7	C001-C7
Preload	T0-T3	T0-T3	T0-T3
Vibration Behaviors	Very Good	Very Good	Very Good
Noise	Very Low	Very Low	Very Low

See unit conversion on page 209.

OVERVIEW & FEATURES

NOOK PROFILE RAIL DESIGN

Nook Heavy Load and High Speed Type Runner Blocks recirculate the balls via a tube. The four rows of balls on the inner runner block are arranged 2 rows each on either side facing each other and contacting at a 45° angle. As the load is transmitted the balls contact the track at two points at an inclusive angle of 90°. In turn, the contact with the outer track is the same making a square load force configuration.

EQUAL LOAD IN FOUR DIRECTIONS

The shape of Nook runner blocks has an equal rated load capacity in any direction. Equal rigidity is therefore obtained in any of the four loading directions making Nook runner blocks ideal for single or combination loads.

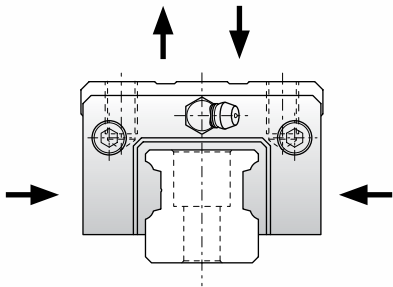

RATIO BALL RECIRCULATION METHOD

Experiments have shown that a ratio of the ball diameter to the return curvature radius of 1.5:1 results in reduced friction with lower noise signature and lower vibration and less variation in friction at high speeds when compared to normal return ratios of 0.6:1 to 1.1:1 as found in standard systems. Nook high-speed runner blocks utilize this ratio.

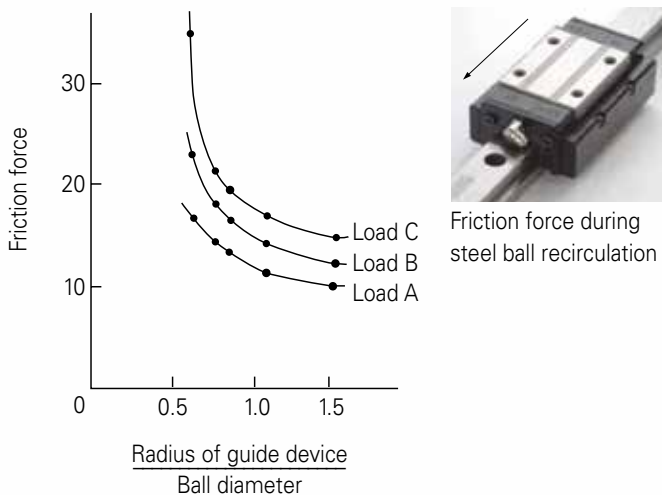

LOW NOISE

As a result of the reduction in friction, the noise vibration signature decreases during travel and consequently reduces the audible noise.

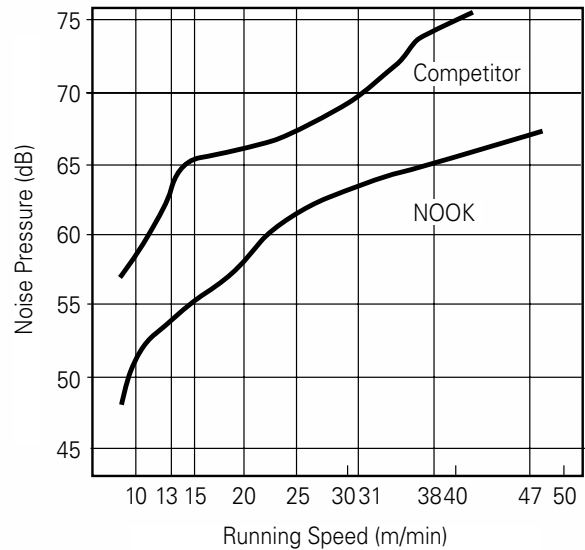

RIGIDITY OF RUNNER BLOCK

The "Tube" Type Nook runner block has a solid structure with no return holes for balls as with the conventional runner block. The tube type design offers a stronger construction, giving the advantage of near equal resistance to deformation in both the radial and reverse radial loaded directions at the sides of the runner block.

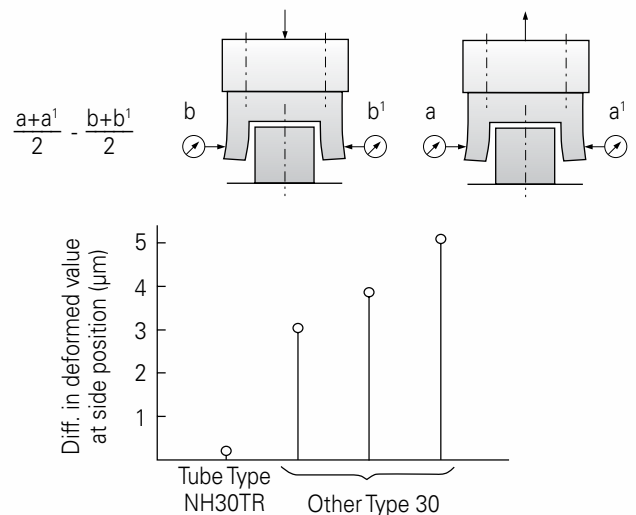

CONSISTENT TRAVELLING ACCURACY

High Speed Type runner blocks have a simple machined form offering continuity of movement at elevated speeds.

NH-TA • NH-TAH **HEAVY LOAD**
HIGH SPEED
FOUR TAPPED HOLES

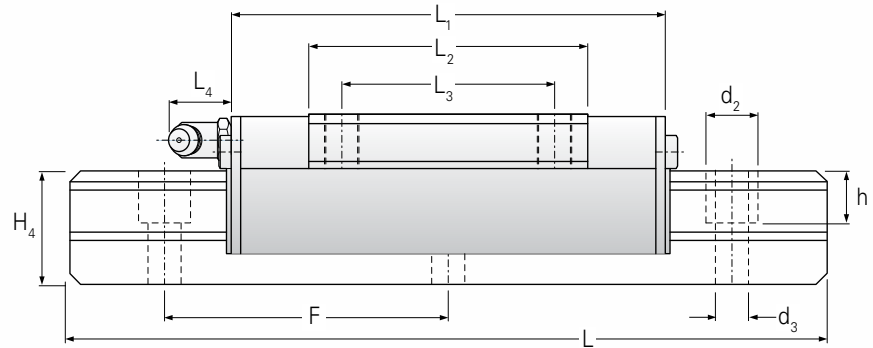
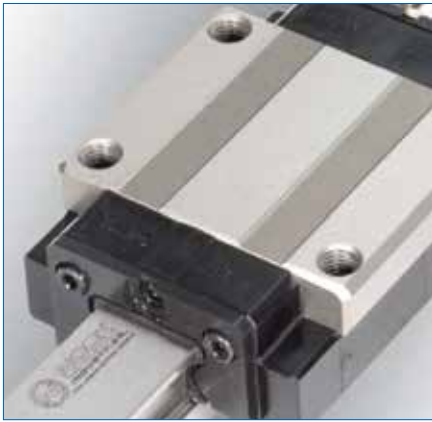

Nook Precision Profile Rail Systems provide stable and efficient linear motion guidance under variable speeds and high load conditions.

- Interchangeable with other manufacturers
- NH-TA provides Heavy Load with Higher Speeds
- Precision Class: C0001 - C7
- Preload: T0 - T3
- Maximum Rail Length:
 NH15: 3000mm
 NH25 thru NH45: 4000mm
 NH55 thru NH65: 3000mm

Model	ASSEMBLY DIMENSIONS			RUNNER BLOCK DIMENSIONS										GREASE FITTING
	Height H	Width W ₁	Length L ₁	W ₂	W ₅	L ₃	M ₁ *	L ₂	H ₃	L ₄	W ₃	H ₁	N	
NH15TA	24	47	71	38	46.5	30	M5×7	38.5	7	0	4.5	4.6	16.0	NAS516-1A
NH20TA	30	63	91	53	60	40	M6×10	50	8	0	5	5	21.5	NAS516-1A
NH25TA	36	70	97	57	66	45	M8×12	59	10	12	6.5	6.5	23.5	B-M6F
NH30TA	42	90	111	72	81	52	M10×14	68	13	12	9	7.0	31.0	B-M6F
NH35TA	48	100	128	82	92	62	M10×16	80	13	12	9	8.0	33.0	B-M6F
NH45TA	60	120	158	100	112	80	M12×19	102	15	14	9	11	37.5	B-PT ¹ / ₈
NH55TA	70	140	189	116	130	95	M14×23	124	15	16	12	14	43.5	B-PT ¹ / ₈
NH65TA	85	170	225	142	162	110	M16×29	148	20	16	14	14	53.5	B-PT ¹ / ₈
NH65TAH	90	170	225	142	162	110	M16×29	148	20	16	14	14	53.5	B-PT ¹ / ₈

See unit conversion on page 209.

* Recommended bolt size x minimum bolt length

NH15TA ▶ NH65TAH

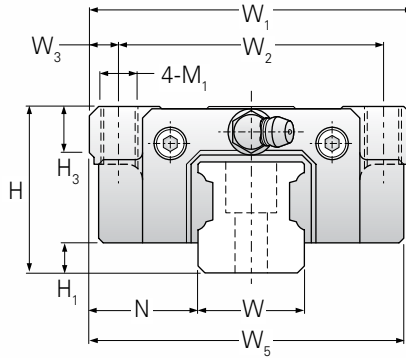

	RAIL DIMENSIONS				BASIC LOAD RATINGS				STATIC MOMENT RATINGS						WEIGHT	
	Height	Width	Pitch	Mount	Dynamic C		Static C_0		M_A		M_B		M_C		Block	Rail
	H_4	W	F	$d_3 \times d_2 \times h$	kN	lb	kN	lb	kN-m	lb-in	kN-m	lb-in	kN-m	lb-in	kg	kg/m
	17	15	60	4.5 × 7.5 × 7	8.43	1,896	13.53	3,041	0.07	608	0.07	608	0.13	1,128	0.21	1.7
	21	20	60	6 × 9.5 × 11	13.92	3,130	23.83	5,157	0.16	1,389	0.16	1,389	0.26	2,344	0.4	2.8
	24	23	60	7 × 11 × 11	20.00	4,496	34.41	7,736	0.27	2,430	0.27	2,430	0.44	3,906	0.64	3.7
	28	28	80	9 × 14 × 14	28.24	6,347	46.86	10,535	0.43	3,819	0.43	3,819	0.72	6,336	1.0	5.3
	32	34	80	9 × 14 × 15	37.55	8,441	62.55	14,061	0.64	5,642	0.64	5,642	1.13	9,982	1.5	7.5
	42	45	105	14 × 20 × 21	60.20	13,532	95.71	21,510	1.30	11,544	1.30	11,544	2.30	20,398	2.7	12.9
	48	53	120	16 × 23 × 24	90.20	20,232	137.09	30,811	2.22	19,617	2.22	19,617	4.25	37,671	4.4	17.3
	58	63	150	18 × 26 × 25	141.11	31,714	215.15	48,354	4.21	37,237	4.21	37,237	7.38	65,360	8.4	24.9
	58	63	150	18 × 26 × 25	141.11	31,714	215.15	48,354	4.21	37,237	4.21	37,237	7.38	65,360	8.4	24.9

NH-TB **HEAVY LOAD**
HIGH SPEED
FOUR THRU HOLES

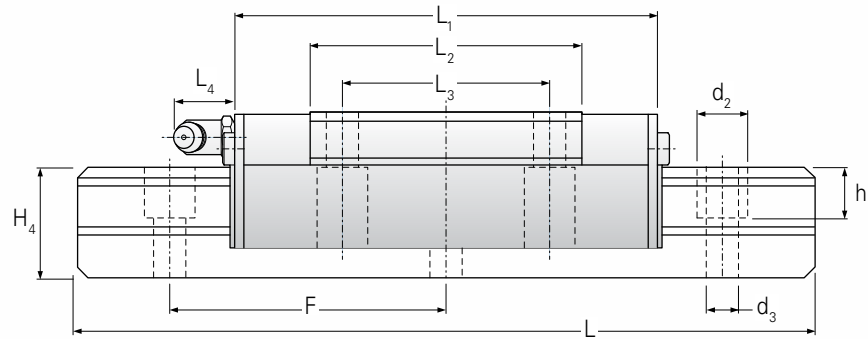

Nook Precision Profile Rail Systems provide stable and efficient linear motion guidance under variable speeds and high load conditions.

- Interchangeable with other manufacturers
- NH-TB provides Heavy Load with Higher Speeds
- Precision Class: C0001 - C7
- Preload: T0 - T3
- Maximum Rail Length:
NH15: 3000mm
NH25 thru NH45: 4000mm
NH55 thru NH65: 3000mm



Model	ASSEMBLY DIMENSIONS			RUNNER BLOCK DIMENSIONS										GREASE FITTING
	Height H	Width W ₁	Length L ₁	W ₂	W ₅	L ₃	d ₁ *	L ₂	H ₃	L ₄	W ₃	H ₁	N	
NH15TB	24	47	71	38	60	30	4.5 × 7	41	5	0	4.5	4.6	16.0	NAS516-1A
NH20TB	30	63	91	53	79	40	6 × 10	58	8	0	5	5.0	21.5	NAS516-1A
NH25TB	36	70	97	57	89	45	7 × 12	59	10	10	6.5	6.5	23.5	B-M6F
NH30TB	42	90	111	72	112	52	9 × 14	68	11	10	9	7.0	31.0	B-M6F
NH35TB	48	100	128	82	123	62	9 × 16	80	13	10	9	8.0	33.0	B-M6F
NH45TB	60	120	158	100	147	80	11 × 19	102	15	12	9	11	37.5	B-PT ¹ / ₈
NH55TB	70	140	189	116	171	95	14 × 23	124	17	12	12	14	43.5	B-PT ¹ / ₈
NH65TB	85	170	225	142	207	110	16 × 29	148	20	12	14	14	53.5	B-PT ¹ / ₈

See unit conversion on page 209.

* Hole diameter × minimum bolt length

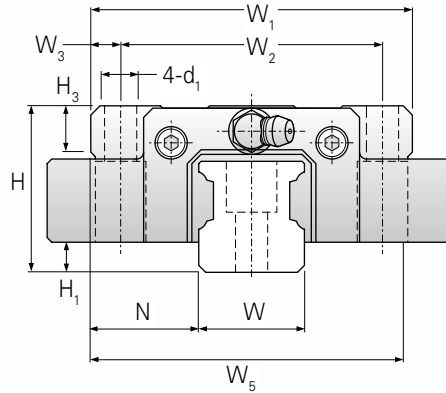
NH15TB ▶ NH65TB



	RAIL DIMENSIONS				BASIC LOAD RATINGS				STATIC MOMENT RATINGS						WEIGHT	
	Height H_4	Width W	Pitch F	Mount $d_3 \times d_2 \times h$	Dynamic C		Static C_0								Block kg	Rail kg/m
					kN	lb	kN	lb	kN-m	lb-in	kN-m	lb-in	kN-m	lb-in		
	17	15	60	4.5 × 7.5 × 7	8.43	1,896	13.53	3,041	0.07	608	0.07	608	0.13	1,128	0.21	1.7
	21	20	60	6 × 9.5 × 11	13.92	3,130	23.83	5,157	0.16	1,389	0.16	1,389	0.26	2,344	0.4	2.8
	24	23	60	7 × 11 × 11	20.00	4,496	34.41	7,736	0.27	2,430	0.27	2,430	0.44	3,906	0.69	3.7
	28	28	80	9 × 14 × 14	28.24	6,347	46.86	10,535	0.43	3,819	0.43	3,819	0.72	6,336	1.0	5.3
	32	34	80	9 × 14 × 15	37.55	8,441	62.55	14,061	0.64	5,642	0.64	5,642	1.13	9,982	1.5	7.5
	42	45	105	14 × 20 × 21	60.20	13,532	95.71	21,510	1.30	11,544	1.30	11,544	2.30	20,398	2.7	12.9
	48	53	120	16 × 23 × 24	90.20	20,232	137.09	30,811	2.22	19,617	2.22	19,617	4.25	37,671	4.4	17.3
	58	63	150	18 × 26 × 25	141.11	31,714	215.15	48,354	4.21	37,237	4.21	37,237	7.38	65,360	8.4	24.9

NH-TR **HEAVY LOAD**
HIGH SPEED
FOUR TAPPED HOLES

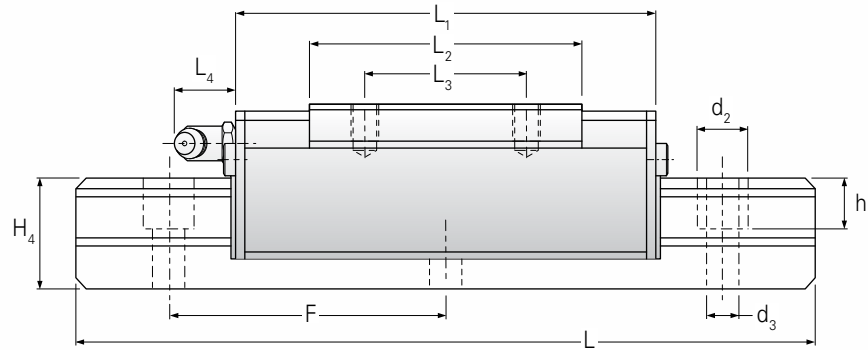

Nook Precision Profile Rail Systems provide stable and efficient linear motion guidance under variable speeds and high load conditions.

- Interchangeable with other manufacturers
- NH-TR provides Heavy Load with Higher Speeds
- Precision Class: C0001 - C7
- Preload: T0 - T3
- Maximum Rail Length:
NH15: 3000mm
NH25 thru NH45: 4000mm
NH55 thru NH65: 3000mm

Model	ASSEMBLY DIMENSIONS			RUNNER BLOCK DIMENSIONS										GREASE FITTING
	Height H	Width W ₁	Length L ₁	W ₂	W ₅	L ₃	M ₁ *	L ₂	H ₃	L ₄	W ₃	H ₁	N	
NH15TR	28	34	71	26	48	26	M4×5	41	6	3	4	4.6	9.5	PB1021B
NH25TR	40	48	97	35	66	35	M6×8	59	8	10	6.5	6.5	12.5	B-M6F
NH30TR	45	60	102	40	81	40	M8×10	59	8	10	10	7.0	16	B-M6F
NH35TR	55	70	128	50	92	50	M8×12	80	10	10	10	8.0	18	B-M6F
NH45TR	70	86	158	60	112	60	M10×17	102	15	12	13	11	20.5	B-PT ¹ / ₈
NH55TR	80	100	189	75	130	75	M12×18	124	18	12	12.5	14	23.5	B-PT ¹ / ₈
NH65TR	90	126	225	90	162	70	M16×20	148	23	12	18	14	31.5	B-PT ¹ / ₈

See unit conversion on page 209.

* Recommended bolt size x minimum bolt length

NH15TR ► NH65TR

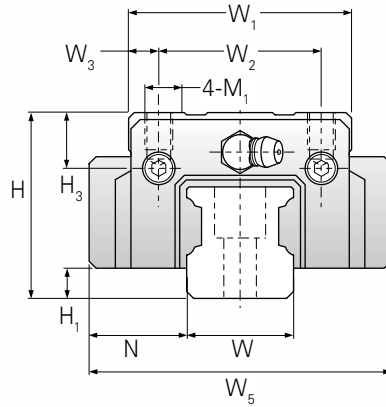

	RAIL DIMENSIONS				BASIC LOAD RATINGS				STATIC MOMENT RATINGS				WEIGHT			
	Height	Width	Pitch	Mount	Dynamic C		Static C ₀		M _A		M _B		M _C		Block	Rail
	H ₄	W	F	d ₃ × d ₂ × h	kN	lb	kN	lb	kN·m	lb-in	kN·m	lb-in	kN·m	lb-in	kg	kg/m
	17	15	60	4.5 × 7.5 × 7	8.43	1,896	13.53	3,041	0.07	608	0.07	608	0.13	1,128	0.21	1.7
	24	23	60	7 × 11 × 11	20.00	4,496	34.41	7,736	0.27	2,430	0.27	2,430	0.44	3,906	0.69	3.7
	28	28	80	9 × 14 × 14	25.00	5,620	39.71	8,926	0.31	2,778	0.31	2,778	0.62	5,468	0.75	5.3
	32	34	80	9 × 14 × 15	37.55	8,441	62.55	14,061	0.64	5,642	0.64	5,642	1.13	9,982	1.5	7.5
	42	45	105	14 × 20 × 21	60.20	13,532	95.71	21,510	1.30	11,544	1.30	11,544	2.30	20,398	2.8	12.9
	48	53	120	16 × 23 × 24	90.02	20,232	137.09	30,811	2.22	19,617	2.22	19,617	4.25	37,671	4.5	17.3
	58	63	150	18 × 26 × 25	141.11	31,714	215.15	48,354	4.21	37,237	4.21	37,237	7.38	65,360	8.7	24.9

**MEDIUM LOAD
COMPACT TYPE**



NU-ER

NU-SER

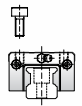
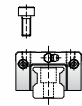
CLASSIFICATION	MEDIUM LOAD TYPE	
	Model Type	Model Type
	NU-ER	NU-SER
Mounting Direction		
Main Fetures	Compact and High Rigidity	
Permissible Speed (m/min)	120	120
Acuracy	C001-C7	C001-C7
Preload	T-T3	T-T3
Vibration Behavior	Low	Low
Noise	Low	Low

See unit conversion on page 209.

OVERVIEW & FEATURES

NOOK PROFILE RAIL DESIGN

Nook Ultra Heavy Load Type Runner Blocks maintain circulation of the balls by a retainer and end cap. The four rows of balls on the inner runner block are arranged in two rows on either side facing each other and contacting at a 45° angle. As the load is transmitted, the balls contact the rail at two points at an inclusive angle of 90°. In turn, the contact with the outer track is the same, making a square load force configuration.

EQUAL LOAD IN FOUR DIRECTIONS

The shape of Nook runner blocks have an equal rated load capacity in any direction. Equal rigidity is therefore obtained in any of the four loading directions making Nook runner blocks ideal for single or combination loads.

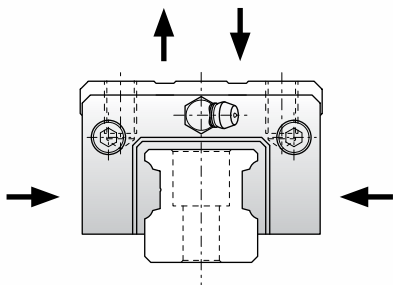

MOUNTING ERROR ABSORPTION AND ROLLING MOMENT RIGIDITY

Nook runner blocks are designed to absorb some of the mounting inaccuracies without any significant increase in the sliding friction.

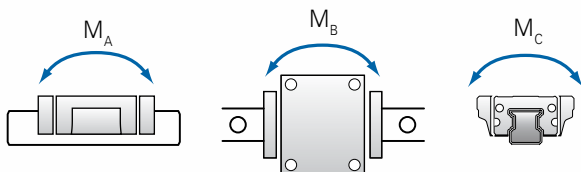

EXCELLENT VIBRATION BEHAVIOR

Nook Heavy Load and Compact Type Runner Blocks have improved dynamic stiffness at high oscillation rates. The four-way load construction offers high rigidity and high dynamic stiffness to eliminate resonance with motor, etc.

ERROR ALLOWANCE IN THE PARRALELISM BETWEEN TWO RAILS - HORIZONTAL PLANE

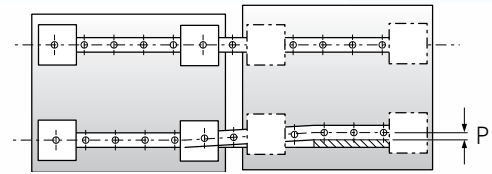

Permissible Tolerance (P) for Parallelism

CLEARANCE

MODEL NU	P		
Model No.	T0	T1	T2-T3
15	—	25	35
20	25	30	40
25	30	35	50
30	35	40	60
35	45	50	70
45	55	60	80
55	65	70	100

Unit = μm

ERROR ALLOWANCE BETWEEN TWO RAILS

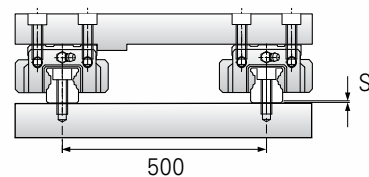

Permissible Tolerance (S) for Two Level

TWO LEVEL OFFSET: The values in the figures show the permissible tolerances for the rail to rail distance of 500 mm. The permissible values are proportional to the rail to rail distances.

CLEARANCE

MODEL NU	S		
Model No.	T0	T1	T2-T3
15	—	100	180
20	80	100	180
25	100	120	200
30	120	150	240
35	170	210	300
45	200	240	360
55	250	300	420

Unit = μm

NU-ER • NU-SER MEDIUM LOAD
COMPACT
 TWO OR FOUR TAPPED HOLES

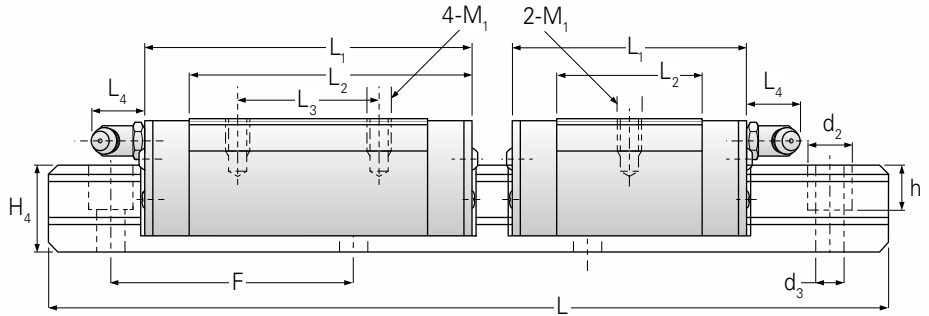

Nook Precision Profile Rail Systems provide stable and efficient linear motion guidance under variable speeds and high load conditions.

- Interchangeable with other manufacturers
- NU-ER and NU-SER provide Compact Design with High Rigidity
- Precision Class: C0001 - C7
- Preload: T0 - T3
- Maximum Rail Length:
 NU15: 1500mm
 NU20 thru NU:65 - 3000mm

Model	ASSEMBLY DIMENSIONS			RUNNER BLOCK DIMENSIONS									GREASE FITTING
	Height H	Width W ₁	Length L ₁	W ₂	L ₃	M ₁ * M	L ₂	H ₃	L ₄	W ₃	H ₁	N	
NU15ER	24	34	58.5	26	26	M4×5	38.5	6	0	4	4.6	9.5	NAS516-1A
NU15SER	24	34	45	26	-	M4×5	25	6	0	4	4.6	9.5	NAS516-1A
NU20ER	28	42	72	32	32	M5×7	50	7.5	0	5	4	11	NAS516-1A
NU20SER	28	42	52	32	-	M5×7	30	7.5	0	5	4	11	NAS516-1A
NU25ER	33	48	83	35	35	M6×8	59	8	12	6.5	4	12.5	B-M6F
NU25SER	33	48	60	35	-	M6×8	36	8	12	6.5	4	12.5	B-M6F
NU30ER	42	60	97	40	40	M8×10	68	8	12	10	7	16	B-M6F
NU30SER	42	60	73	40	-	M8×10	44	8	12	10	7	16	B-M6F
NU35ER	48	70	112	50	50	M8×12	80	10	12	10	8	18	B-M6F
NU35SER	48	70	84	50	-	M8×12	52	10	12	10	8	18	B-M6F
NU45ER	60	86	139	60	60	M10×16	102	15	14	13	11	20.5	B-PT ¹ / ₈
NU55ER	68	100	168	75	75	M12×18	124	18	14	12.5	12	26	B-PT ¹ / ₈

See unit conversion on page 209.

* Recommended bolt size x minimum bolt length

NU15ER ▶ NU55SER

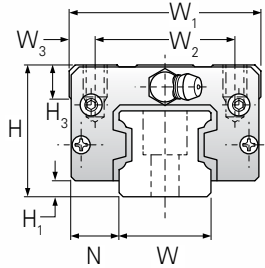

	RAIL DIMENSIONS				BASIC LOAD RATINGS				STATIC MOMENT RATINGS						WEIGHT	
	Height H_4	Width W	Pitch F	Mount $d_3 \times d_2 \times h$	Dynamic C		Static C_0		M_A		M_B		M_C		Block kg	Rail kg/m
					kN	lb	kN	lb	kN·m	lb-in	kN·m	lb-in	kN·m	lb-in		
	17	15	60	3.5 × 6 × 9	8.43	1,895	13.53	3,041	0.07	608	0.07	608	0.13	1,128	0.13	1.7
	17	15	60	3.5 × 6 × 9	5.49	1,234	7.35	1,653	0.3	260	0.3	260	0.07	608	0.08	1.7
	19.5	20	60	6 × 9.5 × 12	13.92	3,130	23.82	5,356	0.16	1,389	0.16	1,389	0.26	2,344	0.27	2.5
	19.5	20	60	6 × 9.5 × 12	9.12	2,050	12.94	2,909	0.05	434	0.05	434	0.15	1,302	0.16	2.5
	21.5	23	60	7 × 11 × 12.5	20.00	4,498	34.41	7,736	0.27	2,430	0.27	2,430	0.44	3,906	0.41	3.2
	21.5	23	60	7 × 11 × 12.5	13.14	2,953	18.63	4,187	0.09	781	0.09	781	0.23	1,996	0.25	3.2
	28	28	80	7 × 11 × 14	28.24	6,347	46.83	10,535	0.43	3,819	0.43	3,819	0.72	6,336	0.9	5.3
	28	28	80	7 × 11 × 14	18.53	4,165	25.49	5,730	0.14	1,215	0.14	1,215	0.39	3,472	0.61	5.3
	32	34	80	9 × 14 × 15	37.55	8,441	62.55	14,061	0.64	5,642	0.64	5,642	1.13	9,982	1.3	7.5
	32	34	80	9 × 14 × 15	28.92	6,502	39.71	8,926	0.27	2,430	0.27	2,430	0.72	6,336	0.84	7.5
	42	45	105	11 × 17.5 × 20.5	60.20	13,532	95.71	21,510	1.30	11,544	1.30	11,544	2.30	20,398	2.2	12.9
	46	53	120	14 × 20 × 25	89.53	20,132	137.09	30,811	2.22	19,617	2.22	19,617	3.95	34,980	3.3	16.5

DEFINING DIMENSIONS FOR GUIDE RAIL
(TOP VIEW OF RAIL)

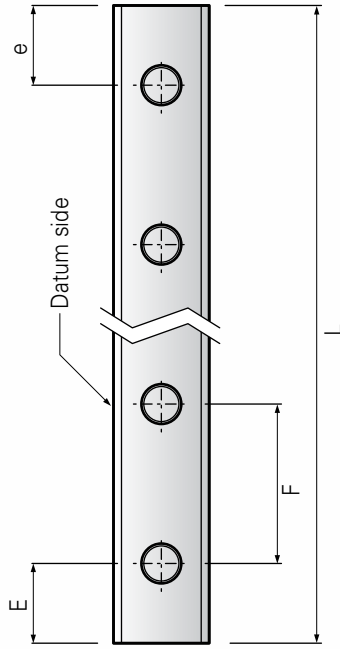

- E DIMENSION _____ mm
- e DIMENSION _____ mm
- L DIMENSION _____ mm
- F STANDARD PITCH DIMENSIONS (BASED ON RAIL SIZE) _____ mm

PART NO. _____

CUSTOMER: _____

DRAWING NO.: _____

P.O. NO.: _____

CUSTOMER REFERENCE: _____

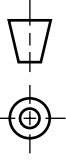
DR. BY: _____ DATE: _____ CHCD BY: _____ DATE: _____ APPROVED BY: _____ DATE: _____	Nook Industries 4950 East 49th Street Cleveland, Ohio 44128 - 1016 USA	
		
TITLE: _____		
Unless otherwise specified dimensions are in mm		SINGLE GUIDE RAIL
THIRDS ANGLE PROJECTION 		GAGE CODE: _____ DWGNO: _____ REV: _____
THIS DRAWING IS THE PROPERTY OF NOOK INDUSTRIES, INC. AND CAN NOT BE REPRODUCED WITHOUT THE EXPRESSED WRITTEN CONSENT OF NOOK INDUSTRIES, INC.		SCALE: _____ SHEET _____ OF _____

FAX TO: (216) 271.7020

PART NO.

DEFINING DIMENSIONS FOR TWO RAILS BEING JOINED
 (TOP VIEW OF RAIL)

The drawing shows two rails joined side-by-side. Dimensions include: E (total width), e (width of one rail), L1 and L2 (lengths of individual rails), L (total length), F (pitch dimension), and e1 (width of one ball). Datum sides are indicated for both rails.

NOOK Industries
 6950 East 40th Street
 Cleveland, Ohio 44125 - 1016 USA

E DIMENSION _____ mm E₁ DIMENSION _____ mm

e DIMENSION _____ mm e₁ DIMENSION _____ mm

L₁ DIMENSION _____ mm L₂ DIMENSION _____ mm

L DIMENSION _____ mm F STANDARD PITCH DIMENSION (BASED ON RAIL SIZE)

CUSTOMER: _____

DRAWING NO.: _____

P.O. NO.: _____

CUSTOMER REFERENCE: _____

Unless otherwise specified dimensions are in mm THIRD ANGLE PROJECTION 	DR. BY: _____ CHCD BY: _____ APPROVED BY: _____	DATE: _____ DATE: _____ DATE: _____	TITLE: TWO GUIDE RAILS JOINED SIZE: _____ GAGE CODE: _____ DWG. NO.: _____ REV: _____ SCALE: _____ SHEET _____ OF _____
---	---	---	---

STANDARD PROFILE BALL RAIL

DEFINING DIMENSIONS FOR THREE RAILS BEING JOINED
(TOP VIEW OF RAIL)

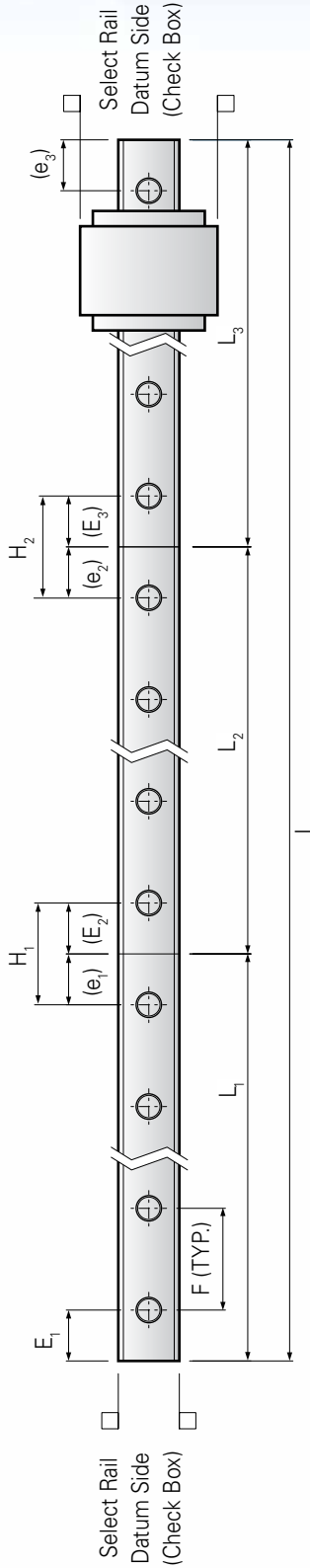

OVERALL LENGTH

$L =$
 $L_1 =$
 $(E_1) =$ +
 $(e_1) =$ -
 $H_1 =$ + -

HOLE-TO-HOLE SPACING

$L_2 =$
 $(E_2) =$
 $(e_2) =$
 $H_2 =$ + -

F = STANDARD PITCH DIMENSION (BASED ON RAIL SIZE)

PART NO. _____

Select Rail Datum Side (Check Box)

Select Rail Datum Side (Check Box)

CUSTOMER: _____

DRAWING NO.: _____

P.O. NO.: _____

CUSTOMER REFERENCE: _____

 Nook Industries 4900 East 49th Street Cleveland, Ohio 44129 - 1018 USA	DR. BY: _____	DATE: _____
	CHCD BY: _____	DATE: _____
APPROVED BY: _____	DATE: _____	TITLE: _____
THIS DRAWING IS THE PROPERTY OF NOOK INDUSTRIES, INC. AND CAN NOT BE REPRODUCED WITHOUT THE EXPRESSED WRITTEN CONSENT OF NOOK INDUSTRIES, INC.		
Unless otherwise specified dimensions are in mm THIRD ANGLE PROJECTION 	GAGE CODE: _____ DWGNO: _____ SCALE: _____	REV: _____ SHEET _____ OF _____

TWO GUIDE RAILS JOINED

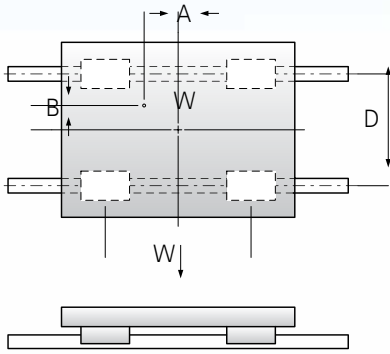
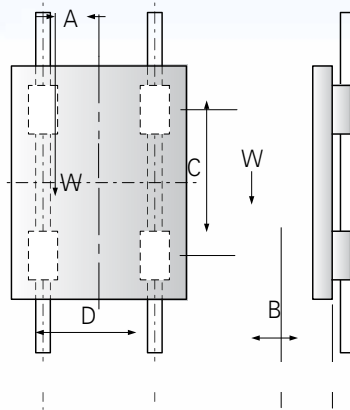
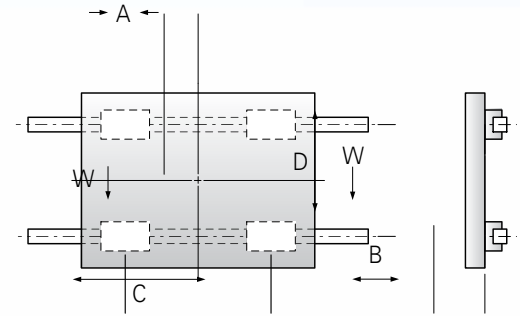
FIG. 1 Horizontal Axis

FIG. 2 Vertical Axis

FIG. 3 Perpendicular Horizontal Axis

RAIL LENGTH

Length: _____ mm

 Orientation: Fig.1 Horizontal Axis Fig.2 Vertical Axis Fig.3 Perpendicular Axis

LOAD

Total Maximum Dynamic Load: _____ kN A: _____ C: _____ W: _____

Total Maximum Static Load: _____ kN B: _____ D: _____

TRAVEL RATE

Average Speed: _____ m/minute Minimum Speed: _____ m/minute

Maximum Acceptable Speed: _____ m/minute

DESIRED LIFE

Distance per cycle: _____ mm (Usually twice the travel)

Number of cycles: _____ /day _____ /year Desired Life: _____ years

APPLICATION EXPLANATION

Please briefly describe the application with as many details as possible. Include drawing, sketch, or order template if available.

CAGED BALL PROFILE RAIL



Nook Caged Ball Profile Rails are used extensively in commercial airplane manufacture.

LINEAR GUIDANCE CAGED BALL PROFILE RAIL



NARC / NHRC CAGED BALL PROFILE RAIL SERIES

Product Overview..... 50-51

PRODUCT DESIGN

Ball Chain..... 52
Lubrication..... 52
Reinforcement Plate Patent 53
Dustproof 53

INSTALLATION NOTICE 54

TECHNICAL INFORMATION 55-56

ORDERING INFORMATION 57

DIMENSION TABLES

NARC Automation Series 58-61
NHRC Heavy Load Series..... 62-65
Rail..... 66
Port Option 67

PRODUCT OVERVIEW NARC / NHRC

Nook's NARC / NHRC Linear Guide Series uses the O-type arrangement for the four row ball circulation design. The contact angle between the rail and ball is 45 degrees, and can realize the 4 directional load effects. NARC / NHRC linear guide blocks have a longer length to allow for a greater M_f value to increase

the rigidity and static moment capability. In addition, runner blocks feature a larger ball bearing, which allow them to outperform competitor's models by 10% to 30% regarding load capabilities. The products have characteristics of high load, high moment, and high stiffness.

Unit = mm

MODE CODE	L_0	H_c
15	12.4	9.35
20	16.4	12.5
25	19.5	14.5
30	24	17
35	30.4	19.5
45	38.2	24
55	43.1	28.5

$$F = M_c / L_0 \quad (L_x)$$

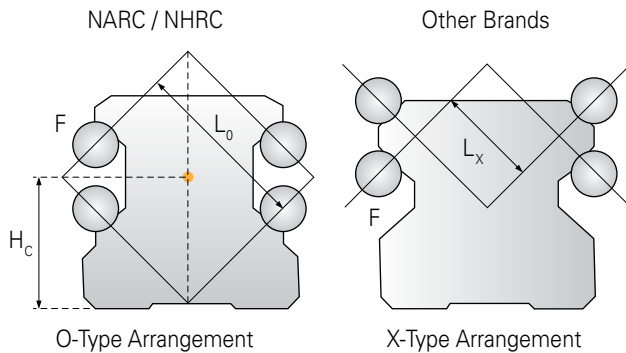

Inner storage lubrication storage pad (bottom)

Stainless steel reinforcement plate

- Total scraping of objects above 0.3mm
- Increase x-axis direction force capacity



LINEAR GUIDANCE CAGED BALL PROFILE RAIL

CAGED BALL PROFILE RAIL

Inner lubrication storage pad (top)

- Length of the runner block will not be increased
- Full lubrication contact with balls, suitable for short stroke movement

End cap

- All-round lubrication holes system

Low abrasion TPU materials end seal

- Low resistance
- Compact high dust proof seal

Ball chain

- Quiet, prolonged service life
- High dynamic load and high load capabilities
- Excellent dynamic performance: $V_{max} > 10$ m/s

PRODUCT DESIGN NARC / NHRC



CAGED BALL CHAIN DESIGN

The Caged Ball Chain Design provides lower friction and lower noise than traditional profile rail block designs. The benefit of a caged ball design prevents the bearings from incidental contact, which reduces friction, wear and noise.

Rotational Ball Chain:

- Reduces noise
- Higher speed in motion
- Prolong service life
- Prolong re-lubrication period

A uniquely patented ball chain design provides a flexible link between the block and bearings. This gives the ball chain enough space to rotate and move in the circulation channel and overcome the friction of the curvature. In addition, the space between upper and bottom parts have oil storage functions, increasing the re-lubrication interval and service life.

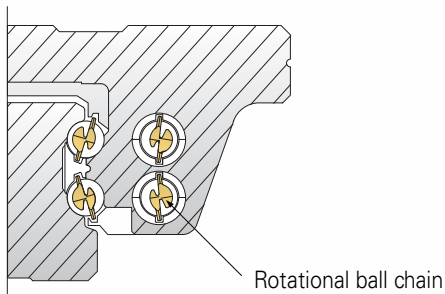

LUBRICATION DESIGN

Inner oil storage and oil supply system design

Inner Lubrication Storage Pad design does not increase length of runner block and contacts directly with ball bearings. Lubrication oil can be injected through lubrication holes. The Lubrication Storage Pad can save enough lubrication oil to ensure long term lubrication effects, conforming to environment protection needs and lowering maintenance costs. Excellent performance when used in short stroke.

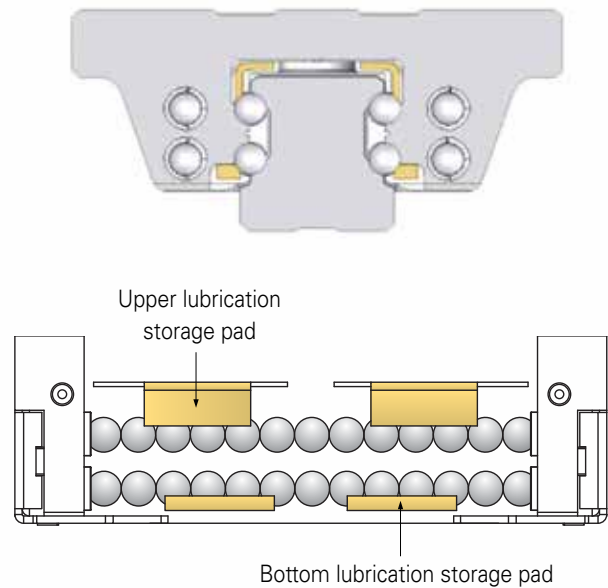

Multi-position lubrication port

The lubrication fittings can be moved from the top, bottom or side of the runner block. An o-ring seal is used for easy/clean lubrication.



REINFORCEMENT PLATE PATENT DESIGN

Using two stainless steel reinforcement plates on each end increases the rigidity of the end caps.

The clearance between the rail profile with the seal design is below 0.3mm, reinforcing the steel plates while having scraper functions.

The NARC / NHRC type uses the stainless steel reinforcement plates to strengthen the bottom retainer, while increasing X-axis direction force capacity, and increasing operation speed.

Velocity_{max} = 10 m/s Acceleration_{max} = 500 m/s²

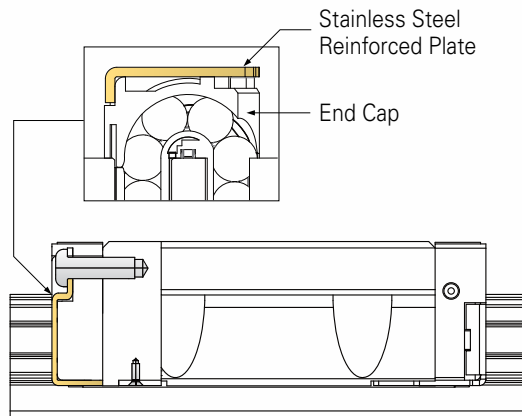

DUSTPROOF DESIGN

Stainless steel reinforcement plate

With clearance between rail profile of no more than 0.3mm, the plate can scrape large items such as iron fillings to protect the end seals.

Inner seals

The newly designed inner seals, slant inward at a 45 degree angle. This protects against foreign objects from sliding into the rails while maintaining low friction. It also allows the lubrication oil to be maintained inside the runner block and prolong the re-lubrication interval.

Bottom seals

The bottom seals can prevent foreign objects from entering the bottom and prevent lubrication from leaking out. The full sealing design reduces the amount of oil usage, prolongs the re-lubrication interval and the service life.

End seals

The Nook double lip type end seals can prevent foreign objects from entering from the side and prevent lubrication oil and grease from leaking. The flexibility of the TPU material has better friction resistance ability and better prevents cracking characteristics than typical NBR plastic.

Standard seals (B): Suitable for most conditions, with slight contact with the rail, having both scraping function with low friction.

Reinforcement seals (S): Seal comes in direct contact with the rail surface, thus having better dustproof and lubrication retention. Nook recommends using this type of seal in environments that are exposed to long periods of high dust. The friction will be higher than standard seals.

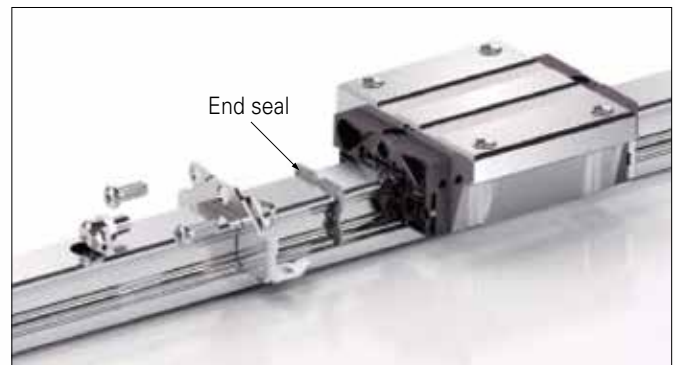

Comparison of friction of seals The friction will be highest on new linear rails. After a short period of operation, friction will reduce to a constant level.

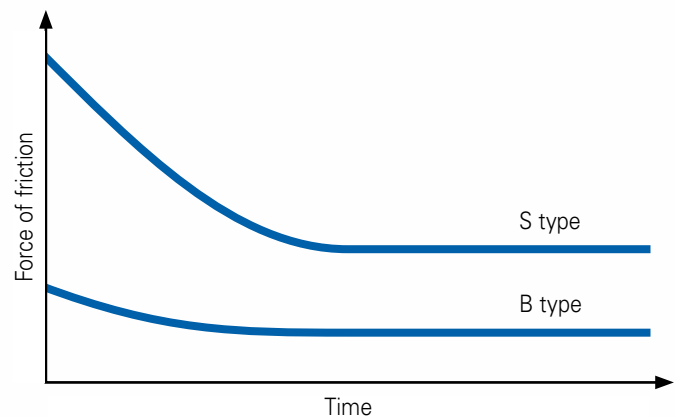

INSTALLATION NOTICE NARC / NHRC

DIMENSION OF REFERENCE EDGE

To ensure the linear guide is precisely assembled with your machined table, Nook machines a recess in the reference edge corner. The corner of the machine table must be smaller than the chamfer of the linear guide to avoid interference.

TYPE	$r_1 \text{ max}$	$r_2 \text{ max}$	h_1	h_2	E
15	.5	.5	4	2.5	3.3
20	.5	.5	5	4	5
25	1	1	5	5	6
30	1	1	6	5.5	6.6
35	1	1	6	6.5	7.6
45	1	1	8	8	9.3
55	1.5	1.5	10	10	12

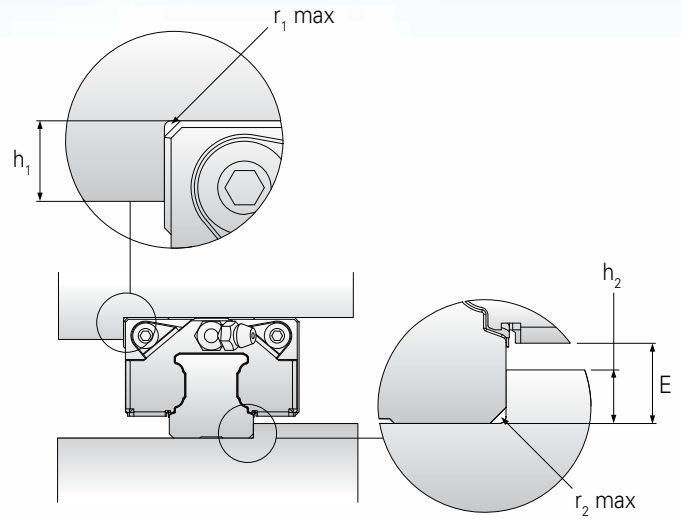

RAIL JOINT

The standard length of rail is 4 meters, Nook provides jointed rail solutions. The joint number will be laser marked on the rail.

1. Follow the joint number to assemble. (Shown in FIG. A)
2. When having two or more rails running in parallel that have butt-joints, Nook suggests setting the joints in different positions between master and slave rail to avoid the change in accuracy. (Shown in FIG. B)
3. Follow the recommended tightening torques to fasten the screws from inside out.

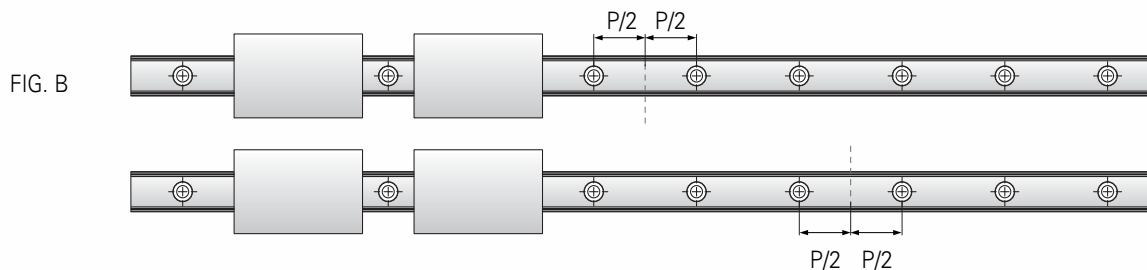
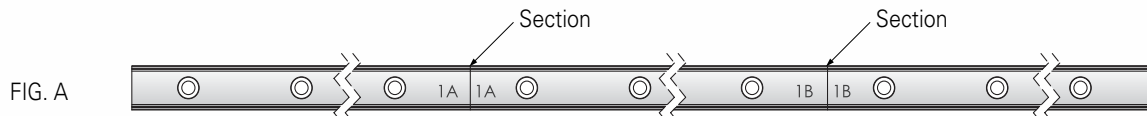

TECHNICAL INFORMATION NARC / NHRC

PRELOAD AND CLEARANCE

The NARC / NHRC linear guides provide the following 4 different preload classes: VC, V0, V1 and V2.

Application

VC = Smooth motion, low friction

V0 = For precision situations, smooth motion

V1 = High stiffness, precision, high load situations

V2 = Super high stiffness, precision, super high load situations

NARC (µm)									
Class	Description	Preload Value	Clearance						
			15	20	25	30	35	45	55
VC*	Micro gap	0	+10~-2	+10~-2	+11~-3	+12~-4	+12~-4	+13~-5	+13~-5
V0	Light preload	.02C	+2~-4	+2~-5	+3~-6	+4~-7	+4~-8	+5~-10	+5~-12
V1	Medium preload	.05C	-4~-10	-5~-12	-6~-15	-7~-18	-8~-20	-10~-24	-12~-28
V2	Heavy preload	.08C	-10~-16	-12~-18	-15~-23	-18~-27	-20~-31	-24~-36	-28~-45

NHRC (µm)									
Class	Description	Preload Value	Clearance						
			15	20	25	30	35	45	55
VC*	Micro gap	0	+10~-2	+10~-2	+11~-3	+12~-4	+12~-4	+13~-5	+13~-5
V0	Light preload	.02C	+2~-4	+2~-5	+3~-6	+4~-7	+4~-8	+5~-10	+5~-12
V1	Medium preload	.08C	-4~-12	-5~-14	-6~-16	-7~-19	-8~-22	-10~-25	-12~-29
V2	Heavy preload	.13C	-11~-19	-14~-23	-16~-26	-19~-31	-22~-35	-25~-40	-29~-46

* Stocked

TECHNICAL INFORMATION NARC / NHRC

ACCURACY

The NARC / NHRC linear guides provide 5 different classes of precision: N, H, P, SP, and UP class. Engineers can choose a different class depending on machine applications.

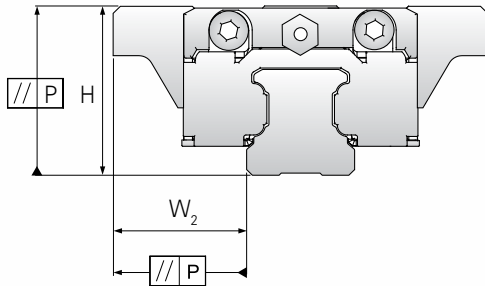

ACCURACY OF RUNNING PARALLELISM

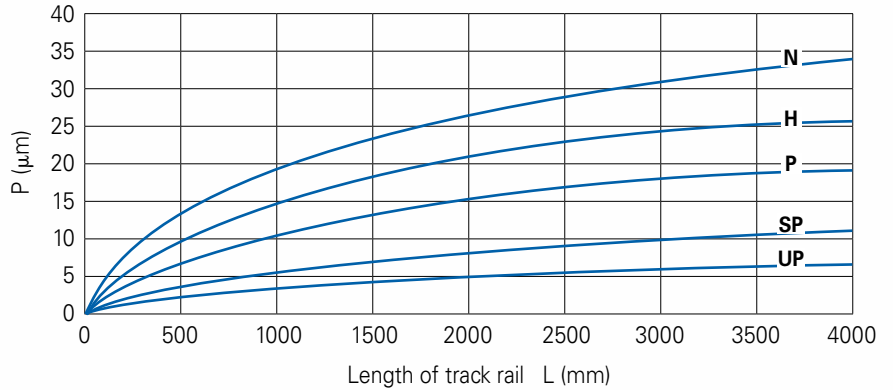

ACCURACY CLASSES

Accuracy Classes (µm)	Normal (N)*	High (H)	Precision (P)	Super Precision (SP)	Ultra Precision (UP)	
Tolerance of dimension height	H	±100	±40	±20	±10	±5
Variation of height for different runner block on the same position of track rail	ΔH	30	15	7	5	3
Tolerance of dimension width	W2	±40	±20	±10	±7	±5
Variation of width for different runner block on the same position of track rail	ΔW2	30	15	7	5	3

APPLICATION

Class	Movement, Motion	Manufacturing Equipment	High Precision Manufacturing Equipment	Test Equipment
N*	●	●		
H	●	●	●	
P		●	●	●
SP			●	●
UP				●
Examples	Mechanical Movers Industrial Robots Office Machinery	Woodworking Machine Punching Press Injection Molding Machine	Lathe/Milling/ Grinding Machine Electrical Discharge Machining (EDM) CNC Machining Center	Three Dimensional Measuring Instrument Detection Mirror/ Head Shaft XY Platform

* Stocked

REFERENCE NUMBER SYSTEM NARC / NHRC

ASSEMBLY

NARC U 15 M N B 2 Z V1 N - 1480L - 20 - 20 W1 JS

PRODUCT TYPE

NARC = Automation series
NHRC = Heavy load series

RAIL TYPE

U = Tapped from the bottom
E = 15 rail with M3 screw

BLOCK

Type 15, 20, 25, 30, 35, 45, 55 ———— **15 M N B**
Width M = Standard F = Wide ————
Length L = Long N = Standard S = Short ————
Seal B = Standard* S = Reinforcement ————

QUANTITY OF RUNNER BLOCK

WITH LUBRICATION STORAGE PAD*

CLASSES

Preload VC = Micro gap V0 = Light V1 = Medium V2 = Heavy
Accuracy N = Normal P = Precision SP = Super Precision UP = Ultra Precision H = High

RAIL

Length (mm) ———— **1480L - 20 - 20**
Starting Hole Pitch (mm) ————
End Hole Pitch (mm) ————

NUMBER OF RAILS ON THE SAME MOVING AXIS

One rail = W1 Two rails = W2

MODIFIER LIST

J = Butt-jointing rail S = Standard, no additional description required
G = Customer designated lubricant M = Modified, additional description required
I = Attached Inspection report
C = Chrome surface treatment is applied to the casing and track rail
CR = Chrome surface treatment is applied to the track rail

* Stock product (with reinforcement end plates and lubrication pad)

RAIL ONLY

NARC 1480L - 20 - 20

PRODUCT TYPE

NARC = Automation series
NHRC = Heavy load series

RAIL

Length (mm) ———— **1480L - 20 - 20**
Starting Hole Pitch (mm) ————
End Hole Pitch (mm) ————

Note: 15 type rail provides another specification (6 × 3.5 × 4.5) for installing screws. If necessary, please contact the Nook Engineering.

NARC AUTOMATION SERIES
MS - SHORT BLOCK LENGTH
MN - STANDARD BLOCK LENGTH
ML - LONG BLOCK LENGTH
TWO OR FOUR TAPPED HOLES

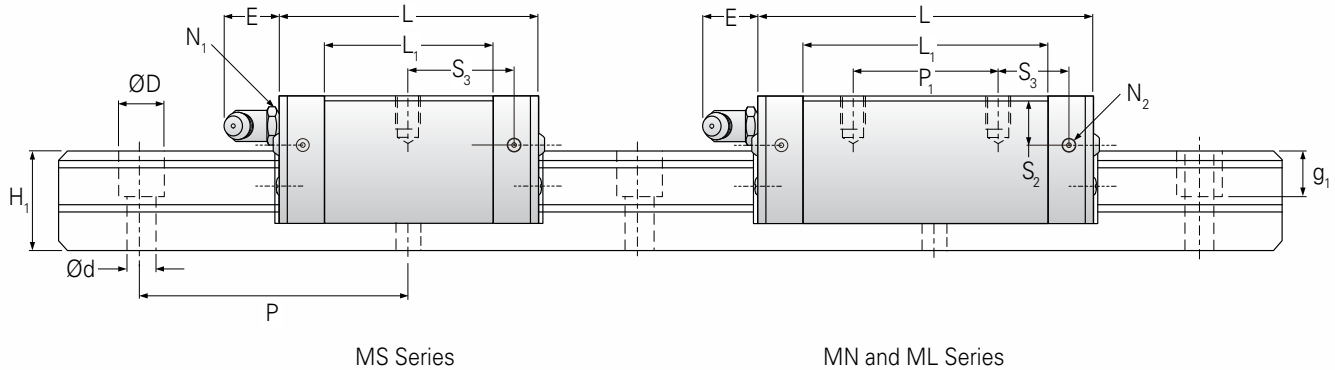

Model	MOUNTING DIMENSIONS		RAIL DIMENSIONS (mm)				BLOCK DIMENSIONS (mm)								
	Height	Width	W ₁	H ₁	P	D × d × g ₁	Width		Length						
	H	W ₂					W	L	L ₁	h ₂	P ₁	P ₂	M × g ₂	T	
NARC MS SERIES	NARC 15 MS	24	9.5	15	15	60	7.5 × 4.5 × 5.3*	34	40.4	26	20.7	—	26	M4 × 7	6
	NARC 20 MS	28	11	20	20	60	9.5 × 6 × 8.5	42	49.2	32.2	23	—	32	M5 × 7	8
	NARC 25 MS	33	12.5	23	23	60	11 × 7 × 9	48	57.4	38.4	27	—	35	M6 × 9	8
	NARC 30 MS	42	16	28	27	80	14 × 9 × 12	60	68	44	35.2	—	40	M8 × 10	12
NARC MN SERIES	NARC 15 MN	24	9.5	15	15	60	7.5 × 4.5 × 5.3*	34	55.9	40.3	20.7	26	26	M4 × 7	6
	NARC 20 MN	28	11	20	20	60	9.5 × 6 × 8.5	42	69	52	23	32	32	M5 × 7	8
	NARC 25 MN	33	12.5	23	23	60	11 × 7 × 9	48	81.2	62.2	27	35	35	M6 × 9	8
	NARC 30 MN	42	16	28	27	80	14 × 9 × 12	60	95.5	71.5	35.2	40	40	M8 × 10	12
	NARC 35 MN	48	18	34	32	80	14 × 9 × 12	70	111.2	86.2	40.4	50	50	M8 × 13	14
	NARC 45 MN	60	20.5	45	39	105	20 × 14 × 17	86	135.5	102.5	50.7	60	60	M10 × 20	14
	NARC 55 MN ▼	70	23.5	53	46	120	20 × 16 × 18	100	155.6	118.6	58	75	75	M12 × 20	16
NARC ML SERIES	NARC 30 ML	42	16	28	27	80	14 × 9 × 12	60	118	94	35.2	60	40	M8 × 10	12
	NARC 35 ML	48	18	34	32	80	14 × 9 × 12	70	136.6	111.6	40.4	72	50	M8 × 13	14
	NARC 45 ML	60	20.5	45	39	105	20 × 14 × 17	86	171.5	138.5	50.7	80	60	M10 × 20	14

* 15 type rail provides another specification (6 × 3.5 × 4.5) for installing screws. If necessary, please contact the Nook Engineering.

▼ The model is in design. N₂=Lube holes (Will be sealed prior to shipping. Remove seal before use.) N₃=O-ring seal

The load capacities are for full ball type (no ball chain).

LINEAR GUIDANCE CAGED BALL PROFILE RAIL

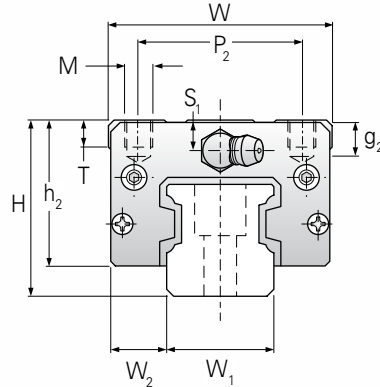

BLOCK DIMENSIONS (mm)								BASIC LOAD RATINGS (kN)		STATIC MOMENT RATINGS (Nm)			WEIGHT	
N ₁	N ₂	N ₃	E	S ₁	S ₂	S ₃	S ₄	Dynamic	Static	M _A	M _B	M _C	Block	Rail
								C	C ₀	g	g/m			
M3 × 6.5	M3 × 6	P3	4.5	4.5	7.5	15.7	16.8	7.7	12.1	50	50	100	96	1,290
M3 × 7.5	M3 × 5.5	P4	10	4	7.4	19.1	19.8	12.5	19.3	100	100	205	170	2,280
M6 × 7.5	M3 × 6.5	P4	12	5	9.3	22.2	23.2	18.2	27.3	160	160	350	300	3,020
M6 × 8.5	M6 × 5	P5	12	7.5	12	27	26.7	23.3	33.1	230	230	520	560	4,380
M3 × 6.5	M3 × 6	P3	3.5	4.5	7.5	9.8	10.9	9.9	17.5	105	105	140	142	1,290
M3 × 7.5	M3 × 5.5	P4	10	4	7.4	13	13.7	17.1	30	230	230	325	266	2,280
M6 × 7.5	M3 × 6.5	P4	12	5	9.3	16.6	17.6	24.8	42.5	385	385	540	420	3,020
M6 × 8.5	M6 × 5	P5	12	7.5	12	20.8	20.5	32.8	53.7	565	565	845	800	4,380
M6 × 10	M6 × 7	P5	12	8	15	23.4	24.1	45.9	82.9	1,080	1,080	1,700	1,120	6,790
PT ¹ / ₈ × 12.5	M6 × 10.5	P5	14	11.1	18.1	27.3	27.2	71.3	122.1	1,910	1,910	3,200	2,120	10,530
PT ¹ / ₈ × 14.5	M6 × 12.5	P5	14	12	19.5	28.5	29.5	103.4	173.1	3,120	3,120	5,030	3,880	14,060
M6 × 8.5	M6 × 5	P5	12	8.7	12	21.7	21.7	39.6	70.2	950	950	1,105	1,138	4,380
M6 × 10	M6 × 7	P5	12	8	15	25.1	25.8	54.7	106.5	1,755	1,755	2,185	1,536	6,790
PT ¹ / ₈ × 12.5	M6 × 10.5	P5	14	11.1	18.1	35	35	89.5	169.1	3,460	3,460	4,430	3,160	10,530

The above rating load capacities and static moment are calculated according to ISO 14728 standard. The rating life for basic dynamic load rating is defined as the total 100km travel distance that 90% of a group of identical linear guides can be operated individually under the same conditions free from any material damage caused by rolling fatigue. When the standard of 50km travel distance is applied, the above basic dynamic load rating C of ISO 14728 should be multiplied by 1.26 for conversion.

NARC **AUTOMATION SERIES**
FS - SHORT BLOCK LENGTH
FN - STANDARD BLOCK LENGTH
TWO OR FOUR THRU HOLES

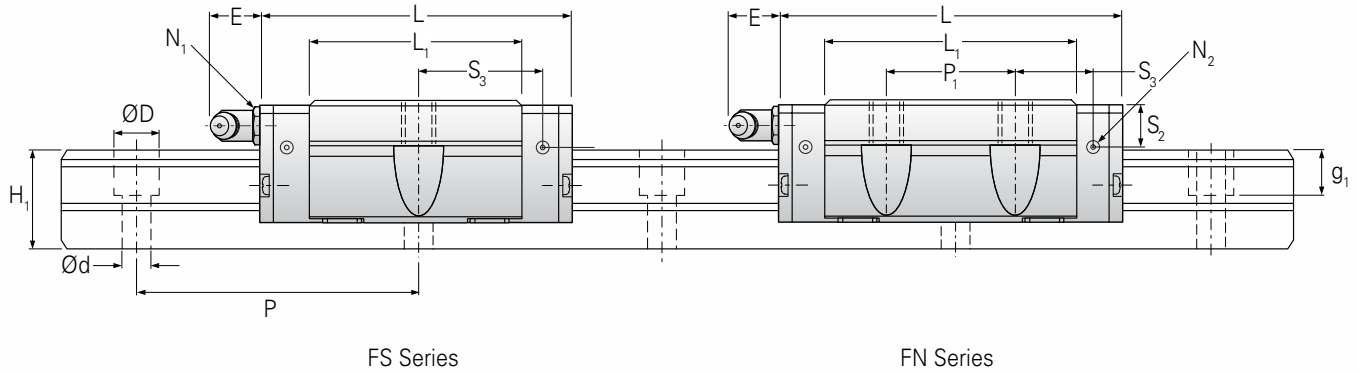

FS Series

FN Series

Model	MOUNTING DIMENSIONS		RAIL DIMENSIONS (mm)				BLOCK DIMENSIONS (mm)								
	Height	Width	W ₁	H ₁	P	D × d × g ₁	Width		Length						
	H	W ₂					W	L	L ₁	h ₂	P ₁	P ₂	M ₁	M × g ₂	
NARC FS SERIES	NARC 15 FS	24	18.5	15	15	60	7.5 × 4.5 × 5.3*	52	41.2	26	20.7	—	41	M4	M5 × 7
	NARC 20 FS	28	19.5	20	20	60	9.5 × 6 × 8.5	59	49.2	32.2	23	—	49	M5	M6 × 10
	NARC 25 FS	33	25	23	23	60	11 × 7 × 9	73	57.4	38.4	27	—	60	M6	M8 × 12
	NARC 30 FS ▼	42	31	28	27	80	14 × 9 × 12	90	68	44	35.2	—	72	M8	M10 × 15
NARC FN SERIES	NARC 15 FN	24	18.5	15	15	60	7.5 × 4.5 × 5.3*	52	55.5	40.3	20.7	26	41	M4	M5 × 7
	NARC 20 FN	28	19.5	20	20	60	9.5 × 6 × 8.5	59	69	52	23	32	49	M5	M6 × 10
	NARC 25 FN	33	25	23	23	60	11 × 7 × 9	73	81.2	62.2	27	35	60	M6	M8 × 12
	NARC 30 FN	42	31	28	27	80	14 × 9 × 12	90	95.5	71.5	35.2	40	72	M8	M10 × 15
	NARC 35 FN	48	33	34	32	80	14 × 9 × 12	100	111.2	86.2	40.4	50	82	M8	M10 × 15

* 15 type rail provides another specification (6 × 3.5 × 4.5) for installing screws. If necessary, please contact Nook Engineering.

▼ The model is in design. N₂=Lube holes (Will be sealed prior to shipping. Remove seal before use.) N₃=O-ring seal
 The load capacities are for full ball type (no ball chain).

LINEAR GUIDANCE CAGED BALL PROFILE RAIL

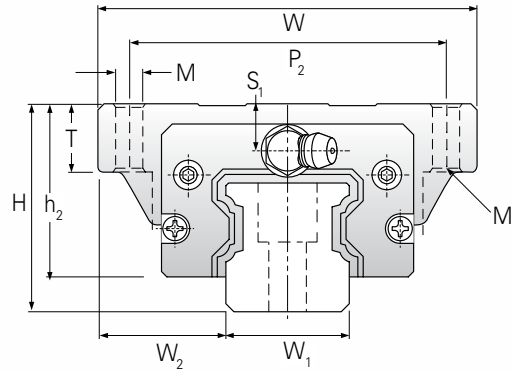

BLOCK DIMENSIONS (mm)										BASIC LOAD RATINGS (kN)		STATIC MOMENT RATINGS (Nm)			WEIGHT	
T	N ₁	N ₂	N ₃	E	S ₁	S ₂	S ₃	S ₄	C	C ₀	M _A	M _B	M _C	Block g	Rail g/m	
7	M3 × 6.5	M3 × 6	P3	3.5	4.5	7.5	15.7	16.8	7.7	12.1	50	50	100	122	1,290	
10	M3 × 7.5	M3 × 5.5	P4	10	4	7.4	19.1	19.8	12.5	19.3	100	80	205	210	2,280	
12	M6 × 7.5	M3 × 6.5	P4	12	5	9.3	22.2	23.2	18.2	27.3	160	160	350	345	3,020	
15	M6 × 8.5	M6 × 5	P5	12	7.5	12	27	26.8	23.3	33.1	230	230	520	750	4,380	
7	M3 × 6.5	M3 × 6	P3	3.5	4.5	7.5	8.9	10.9	9.9	17.5	105	105	140	184	1,290	
10	M3 × 7.5	M3 × 5.5	P4	10	4	7.4	13	13.7	17.1	30	230	230	325	336	2,280	
12	M6 × 7.5	M3 × 6.5	P4	12	5	9.3	16.6	17.6	24.8	42.5	385	385	540	524	3,020	
15	M6 × 8.5	M6 × 5	P5	12	7.5	12	20.8	20.5	32.8	53.7	565	565	845	1,200	4,380	
15	M6 × 10	M6 × 7	P5	12	8	15	23.4	24.1	45.9	82.9	1,080	1,080	1,700	1,580	6,790	

The above rating load capacities and static moment are calculated according to ISO 14728 standard. The rating life for basic dynamic load rating is defined as the total 100km travel distance that 90% of a group of identical linear guides can be operated individually under the same conditions free from any material damage caused by rolling fatigue. When the standard of 50km travel distance is applied, the above basic dynamic load rating C of ISO 14728 should be multiplied by 1.26 for conversion.

NHRC HEAVY LOAD SERIES
MN - STANDARD BLOCK LENGTH
ML- LONG BLOCK LENGTH
FOUR TAPPED HOLES

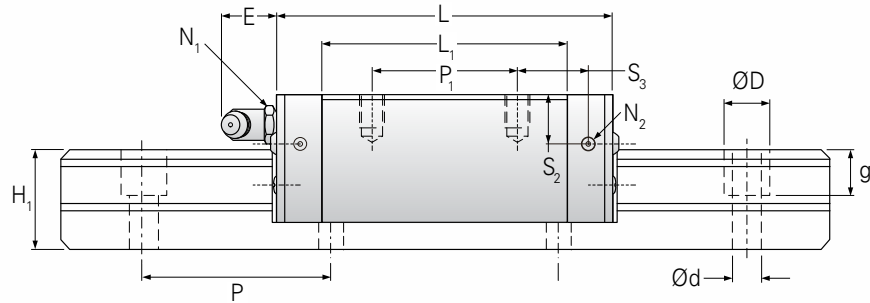

Model	MOUNTING DIMENSIONS		RAIL DIMENSIONS (mm)				BLOCK DIMENSIONS (mm)								
	Height H	Width W ₂	W ₁	H ₁	P	D × d × g ₁	Width W	Length L	L ₁	h ₂	P ₁	P ₂	M × g ₂	T	
NHRC MN SERIES	NHRC 15 MN	28	9.5	15	15	60	7.5 × 4.5 × 5.3*	34	55.9	40.3	34.7	26	26	M4 × 7	6
	NHRC 20 MN	30	12	20	20	60	9.5 × 6 × 8.5	44	70.2	52	24.5	36	32	M5 × 8.5	8
	NHRC 25 MN	40	12.5	23	23	60	11 × 7 × 9	48	81.2	62.2	34	35	35	M6 × 9	12
	NHRC 30 MN	45	16	28	27	80	14 × 9 × 12	60	95.5	71.5	38.4	40	40	M8 × 12	12
	NHRC 35 MN	55	18	34	32	80	14 × 9 × 12	70	111.2	86.2	47.4	50	50	M8 × 13	14
	NHRC 45 MN	70	20.5	45	39	105	20 × 14 × 17	86	135.5	102.5	60.7	60	60	M10 × 20	14
	NHRC 55 MN ▼	80	23.5	53	46	120	24 × 16 × 18	100	155.6	118.6	68	75	75	M12 × 24	16
NHRC ML SERIES	NHRC 20 ML	30	12	20	20	60	9.5 × 6 × 8.5	44	87.2	70.2	25	50	32	M5 × 8.5	6
	NHRC 25 ML	40	12.5	23	23	60	11 × 7 × 9	48	105	86	34	50	35	M6 × 9	12
	NHRC 30 ML	45	16	28	27	80	14 × 9 × 12	60	118	94	38.4	60	40	M8 × 12	12
	NHRC 35 ML	55	18	34	32	80	14 × 9 × 12	70	136.6	111.6	47.4	72	50	M8 × 13	14
	NHRC 45 ML	70	20.5	45	39	105	20 × 14 × 17	86	171.5	138.5	60.7	80	60	M10 × 20	14
	NHRC 55 ML ▼	80	23.5	53	46	120	24 × 16 × 18	100	202.5	165.5	68	95	75	M12 × 24	16

* 15 type rail provides another specification (6 × 3.5 × 4.5) for installing screws. If necessary, please contact the Nook Engineering.

▼ The model is in design. N₂=Lube holes (Will be sealed prior to shipping. Remove seal before use.) N₃=O-ring seal
 The load capacities are for full ball type (no ball chain).

LINEAR GUIDANCE CAGED BALL PROFILE RAIL

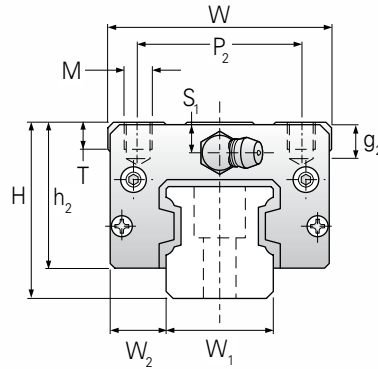

CAGED BALL PROFILE RAIL

BLOCK DIMENSIONS (mm)								BASIC LOAD RATINGS (kN)		STATIC MOMENT RATINGS (Nm)			WEIGHT	
N_1	N_2	N_3	E	S_1	S_2	S_3	S_4	C	C_0	M_A	M_B	M_C	Block g	Rail g/m
M3 × 6.5	M3 × 6	P3	3.5	8.5	11.5	9.8	10.9	9.9	17.5	105	105	140	184	1,290
M3 × 7.5	M3 × 5.5	P4	10	6	9.4	11	11.7	17.1	30	230	230	325	318	2,280
M6 × 7.5	M3 × 6.5	P4	12	12	16.3	16.6	17.6	24.8	42.5	385	385	540	578	3,020
M6 × 8.5	M6 × 5	P5	12	10.5	15	20.8	20.5	32.8	53.7	565	565	845	896	4,380
M6 × 10	M6 × 7	P5	12	15	22	23.4	24.1	45.9	82.9	1,080	1,080	1,700	1,430	6,790
PT $\frac{1}{8}$ × 12.5	M6 × 10.5	P5	14	21.1	28.1	27.3	27.3	71.3	122.1	1,910	1,910	3,200	2,794	10,530
PT $\frac{1}{8}$ × 14.5	M6 × 12.5	P5	14	22	29.5	28.5	29.5	103.4	173.1	3,120	3,120	5,030	4,780	14,060
M3 × 7.5	M3 × 5.5	P4	10	6	9.4	13.1	13.8	20.4	38.5	390	390	415	142	1,290
M6 × 7.5	M3 × 6.5	P4	12	12	16.3	21	22	30.7	57.7	710	710	735	685	3,020
M6 × 8.5	M6 × 5	P5	12	10.5	15	21.7	21.8	39.6	70.2	950	950	1,105	1,150	4,380
M6 × 10	M6 × 7	P5	12	15	22	25.1	25.8	54.7	106.5	1,755	1,755	2,185	1,953	6,790
PT $\frac{1}{8}$ × 12.5	M6 × 10.5	P5	14	21.1	28.1	35	35	89.5	169.1	3,460	3,460	4,430	4,060	10,530
PT $\frac{1}{8}$ × 14.5	M6 × 12.5	P5	14	22	29.5	42	43	129.9	239.7	5,855	5,855	6,965	6,060	14,060

The above rating load capacities and static moment are calculated according to ISO 14728 standard. The rating life for basic dynamic load rating is defined as the total 100km travel distance that 90% of a group of identical linear guides can be operated individually under the same conditions free from any material damage caused by rolling fatigue. When the standard of 50km travel distance is applied, the above basic dynamic load rating C of ISO 14728 should be multiplied by 1.26 for conversion.

NHRC HEAVY LOAD SERIES
FN - STANDARD BLOCK LENGTH
FL- LONG BLOCK LENGTH
FOUR THRU HOLES

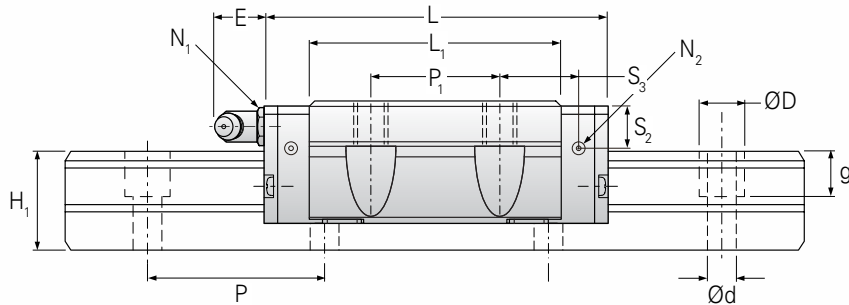

Model	MOUNTING DIMENSIONS		RAIL DIMENSIONS (mm)				BLOCK DIMENSIONS (mm)								
	Height H	Width W ₂	W ₁	H ₁	P	D × d × g ₁	Width W	Length L	L ₁	h ₂	P ₁	P ₂	M × g ₂	M ₁	
NHRC FN SERIES	NHRC 15 FN	24	16	15	15	60	7.5 × 4.5 × 5.3*	47	55.5	40.3	20.7	30	38	M5 × 7	M4
	NHRC 20 FN	30	21.5	20	20	60	9.5 × 6 × 8.5	63	69	52	25	40	53	M6 × 10	M5
	NHRC 25 FN	36	23.5	23	23	60	11 × 7 × 9	70	81.2	62.2	30	45	57	M8 × 12	M6
	NHRC 30 FN	42	31	28	27	80	14 × 9 × 12	90	95.5	71.5	35.5	52	72	M10 × 15	M8
	NHRC 35 FN	48	33	34	32	80	14 × 9 × 12	100	111.2	86.2	40.4	62	82	M10 × 15	M8
	NHRC 45 FN	60	37.5	45	39	105	20 × 14 × 17	120	135.5	102.5	50.7	80	100	M12 × 18	M10
	NHRC 55 FN ▼	70	23.5	53	46	120	24 × 16 × 18	140	155.6	118.6	58	95	116	M14 × 20	M12
NHRC FL SERIES	NHRC 20 FL	30	21.5	20	20	60	9.5 × 6 × 8.5	63	87.2	70.2	25	40	53	M6 × 10	M5
	NHRC 25 FL	36	23.5	23	23	60	11 × 7 × 9	70	105	86	30	45	57	M8 × 12	M6
	NHRC 30 FL	42	31	28	27	80	14 × 9 × 12	90	148	94	35.2	52	72	M10 × 15	M8
	NHRC 35 FL	48	33	34	32	80	14 × 9 × 12	100	136.6	111.6	40.4	62	82	M10 × 15	M8
	NHRC 45 FL	60	37.5	45	39	105	20 × 14 × 17	120	171.5	138.5	50.7	80	100	M12 × 18	M10
	NHRC 55 FL ▼	70	23.5	53	46	120	24 × 16 × 18	140	202.5	165.5	58	95	116	M14 × 20	M12

* 15 type rail provides another specification (6 × 3.5 × 4.5) for installing screws. If necessary, please contact Nook Engineering.



▼ The model is in design. N₂=Lube holes (Will be sealed prior to shipping. Remove seal before use.) N₃=O-ring seal

The load capacities are for full ball type (no ball chain).

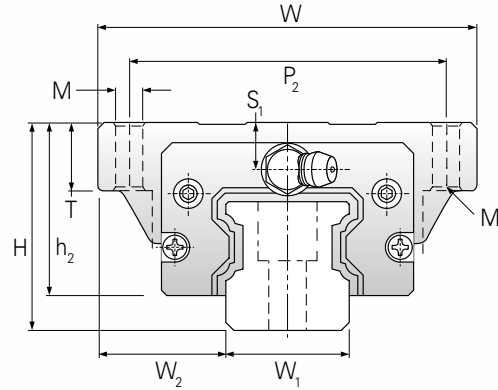
LINEAR GUIDANCE CAGED BALL PROFILE RAIL



CAGED BALL PROFILE RAIL

BLOCK DIMENSIONS (mm)									BASIC LOAD RATINGS (kN)		STATIC MOMENT RATINGS (Nm)			WEIGHT	
T	N ₁	N ₂	N ₃	E	S ₁	S ₂	S ₃	S ₄	C	C ₀				Block g	Rail g/m
7	M3 × 6.5	M3 × 6	P3	3.5	4.5	7.5	7.8	8.9	9.9	17.5	105	105	140	174	1,290
10	M3 × 7.5	M3 × 5.5	P4	10	6	9.4	9	9.7	17.1	30	230	230	325	396	2,280
12	M6 × 7.5	M3 × 6.5	P4	12	8	12.3	11.6	12.6	24.8	42.5	385	385	540	626	3,020
16	M6 × 8.5	M6 × 5	P5	12	7.5	12	14.8	14.5	32.8	53.7	565	565	845	1,110	4,380
16	M6 × 10	M6 × 7	P5	12	8	15	17.4	18.1	45.9	82.9	1,080	1,080	1,700	1,550	6,790
19	PT ¹ / ₈ × 12.5	M6 × 10.5	P5	14	11.1	18.1	17.3	17.3	71.3	122.1	1,910	1,910	3,200	2,747	10,530
20	PT ¹ / ₈ × 14.5	M6 × 12.5	P5	14	12	19.5	28.5	29.5	103.4	173.1	3,120	3,120	5,030	5,260	14,060
9	M3 × 7.5	M3 × 5.5	P4	10	4	9.4	18.1	18.8	20.4	38.5	390	390	415	504	2,280
12	M6 × 7.5	M3 × 6.5	P4	12	8	12.3	23.5	24.5	30.7	57.7	710	710	735	605	3,020
16	M6 × 8.5	M6 × 5	P5	12	7.5	12	25.7	25.8	39.6	70.2	950	950	1,105	1,385	4,380
16	M6 × 10	M6 × 7	P5	12	8	15	30.1	30.8	54.7	106.5	1,755	1,755	2,185	2,000	6,790
19	PT ¹ / ₈ × 12.5	M6 × 10.5	P5	14	11.1	18.1	35	35	89.5	169.1	3,460	3,460	4,430	4,280	10,530
20	PT ¹ / ₈ × 14.5	M6 × 12.5	P5	14	12	19.5	42	43	129.9	239.7	5,855	5,855	6,965	7,480	14,060

The above rating load capacities and static moment are calculated according to ISO 14728 standard. The rating life for basic dynamic load rating is defined as the total 100km travel distance that 90% of a group of identical linear guides can be operated individually under the same conditions free from any material damage caused by rolling fatigue. When the standard of 50km travel distance is applied, the above basic dynamic load rating C of ISO 14728 should be multiplied by 1.26 for conversion.

NARC / NHRC RAIL TAPPED FROM BOTTOM DIMENSIONS
NARC - AUTOMATION SERIES
NHRC - HEAVY LOAD SERIES

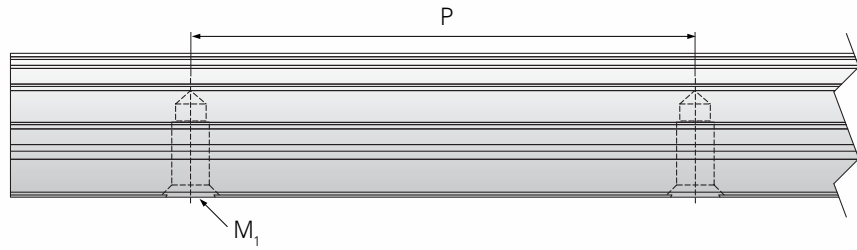
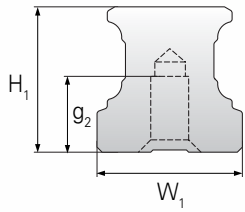

RAIL (tapped from the bottom)

Model Code		W_1	H_1	P	M x g_3	Lmax	Rail (g/m)
NARC-U 15	NHRC-U 15	15	15	60	M5 x 8	4,000	1,290
NARC-U 20	NHRC-U 20	20	20	60	M6 x 10	4,000	2,280
NARC-U 25	NHRC-U 25	23	23	60	M6 x 12	4,000	3,020
NARC-U 30	NHRC-U 30	28	27	60	M8 x 15	4,000	4,380
NARC-U 35	NHRC-U 35	34	32	80	M8 x 15	4,000	6,790
NARC-U 45	NHRC-U 45	45	39	105	M12 x 19	4,000	10,530
NARC-U 55	NHRC-U 55	53	46	120	M14 x 22	4,000	14,060

PORT OPTION

Type		Port Size		Standard	Option	
		Section	Side			
NARC 15	NHRC 15	15	60	A-M3	OB-M3-M6	—
NARC 20	NHRC 20	20	60	B-M3	OB-M3-M6	—
NARC 25	NHRC 25	23	60	B-M6	OA-M6-M8(PT $\frac{1}{8}$)	OB-M6-M8(PT $\frac{1}{8}$)
NARC 30	NHRC 30	27	60	B-M6	OA-M6-M8(PT $\frac{1}{8}$)	OB-M6-M8(PT $\frac{1}{8}$)
NARC 35	NHRC 35	32	80	B-M/6	OA-M6-M8(PT $\frac{1}{8}$)	OB-M6-M8(PT $\frac{1}{8}$)
NARC 45	NHRC 45	39	105	B-PT $\frac{1}{8}$	OA-PT $\frac{1}{8}$ -M8(PT $\frac{1}{8}$)	OB-PT $\frac{1}{8}$ -M8(PT $\frac{1}{8}$)
NARC 55	NHRC 55	46	120	B-PT $\frac{1}{8}$	OA-PT $\frac{1}{8}$ -M8(PT $\frac{1}{8}$)	OB-PT $\frac{1}{8}$ -M8(PT $\frac{1}{8}$)

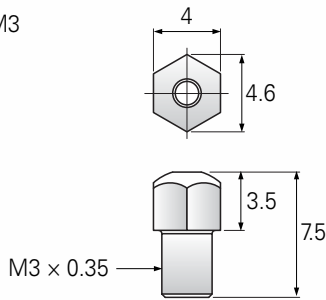
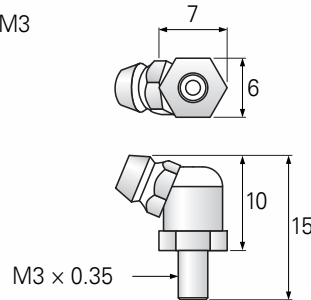
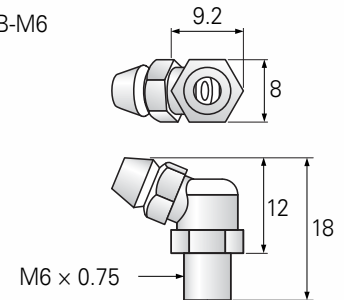
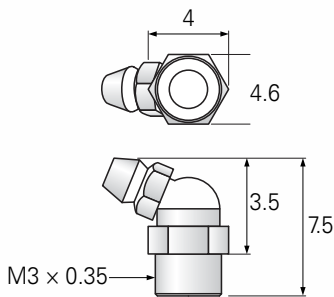
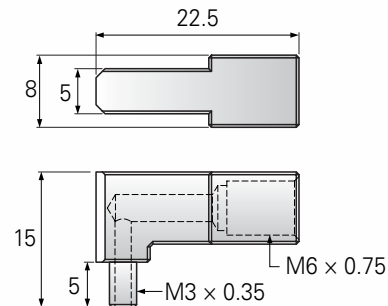
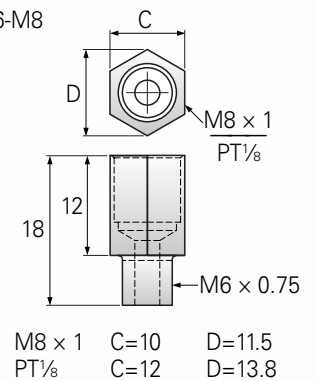
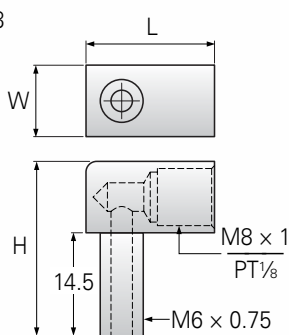
A-M3

B-M3

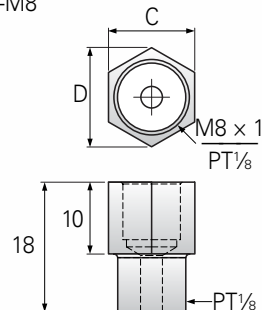
B-M6

B-PT $\frac{1}{8}$

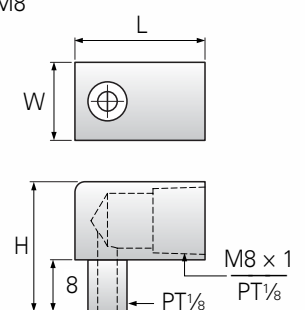
OB-M3-M6

**OA-M6-M8
(PT $\frac{1}{8}$)**

**OB-M6-M8
(PT $\frac{1}{8}$)**

M8 x 1 L=18 W=10 H=24.5
PT $\frac{1}{8}$ L=18 W=12 H=24.5

**OA-PT $\frac{1}{8}$ -M8
(PT $\frac{1}{8}$)**

M8 x 1 C=10 D=11.5
PT $\frac{1}{8}$ C=12 D=13.8

**OB-PT $\frac{1}{8}$ -M8
(PT $\frac{1}{8}$)**

M8 x 1 L=18 W=10 H=20
PT $\frac{1}{8}$ L=20 W=12 H=20

MINIATURE LINEAR BALL RAILS



Nook Miniature Rails are used in many instrument series applications.

LINEAR GUIDANCE

MINATURE LINEAR BALL RAILS



NMR MINIATURE LINEAR GUIDE SERIES

Product Introduction.....	70-71
New Design.....	72

TECHNICAL INFORMATION

Accuracy.....	73
Preload.....	73
Load Capacity and Rating Life.....	74
Friction.....	75
Lubrication.....	76

INSTALLATION ILLUSTRATION.....	78-79
--------------------------------	-------

ORDERING INFORMATION.....	80-81
---------------------------	-------

DIMENSIONS AND SPECIFICATIONS

Standard NMR - M SU series.....	82-83
Standard NMR - M ZU series.....	84-85
Standard NMR - M SS series.....	86-87
Standard NMR - M ZZ series.....	88-89
Standard NMR - M SUE series.....	90-91
Standard NMR - M ZUE series.....	90-91
Standard NMR - M EE series.....	92-93
Standard NMR - M EZ series.....	92-93
Standard NMR - M EU series.....	94-95
Standard NMR - M UZ series.....	94-95
Wide NMR - M SU series.....	96-97
Wide NMR - M ZU series.....	98-99
Wide NMR - W SS series.....	100-101
Wide NMR - W ZZ series.....	102-103
Wide NMR - M SUE series.....	104-105
Wide NMR - M ZUE series.....	104-105
Wide NMR - W EE series.....	106-107
Wide NMR - W EZ series.....	106-107
Wide NMR - M EU series.....	108-109
Wide NMR - M UZ series.....	108-109

MINIATURE LINEAR BALL RAILS

PRODUCT INTRODUCTION

Precision

NMR Miniature linear guide series have three accuracy grades for design selection: Precision (P), High (H), Normal (N).

Material

Regardless of series, NMR miniature linear guides use stainless steel processed material.

Embedded inverse return design

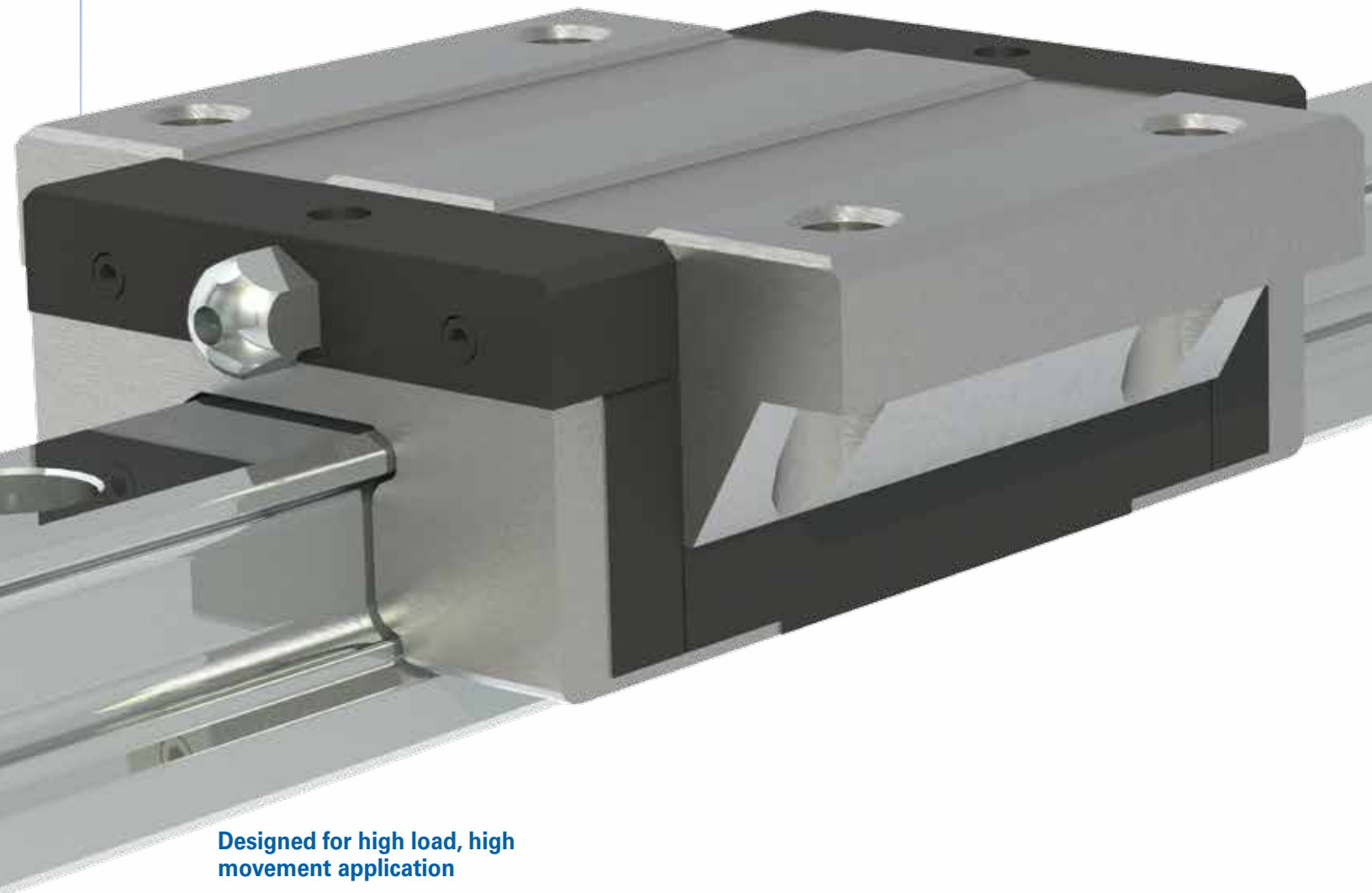

Designed for high load, high movement application

LINEAR GUIDANCE

MINIATURE LINEAR BALL RAILS

Unique ball re-circulation design

Steel reinforcement plate ensures sturdy assembly and longer life

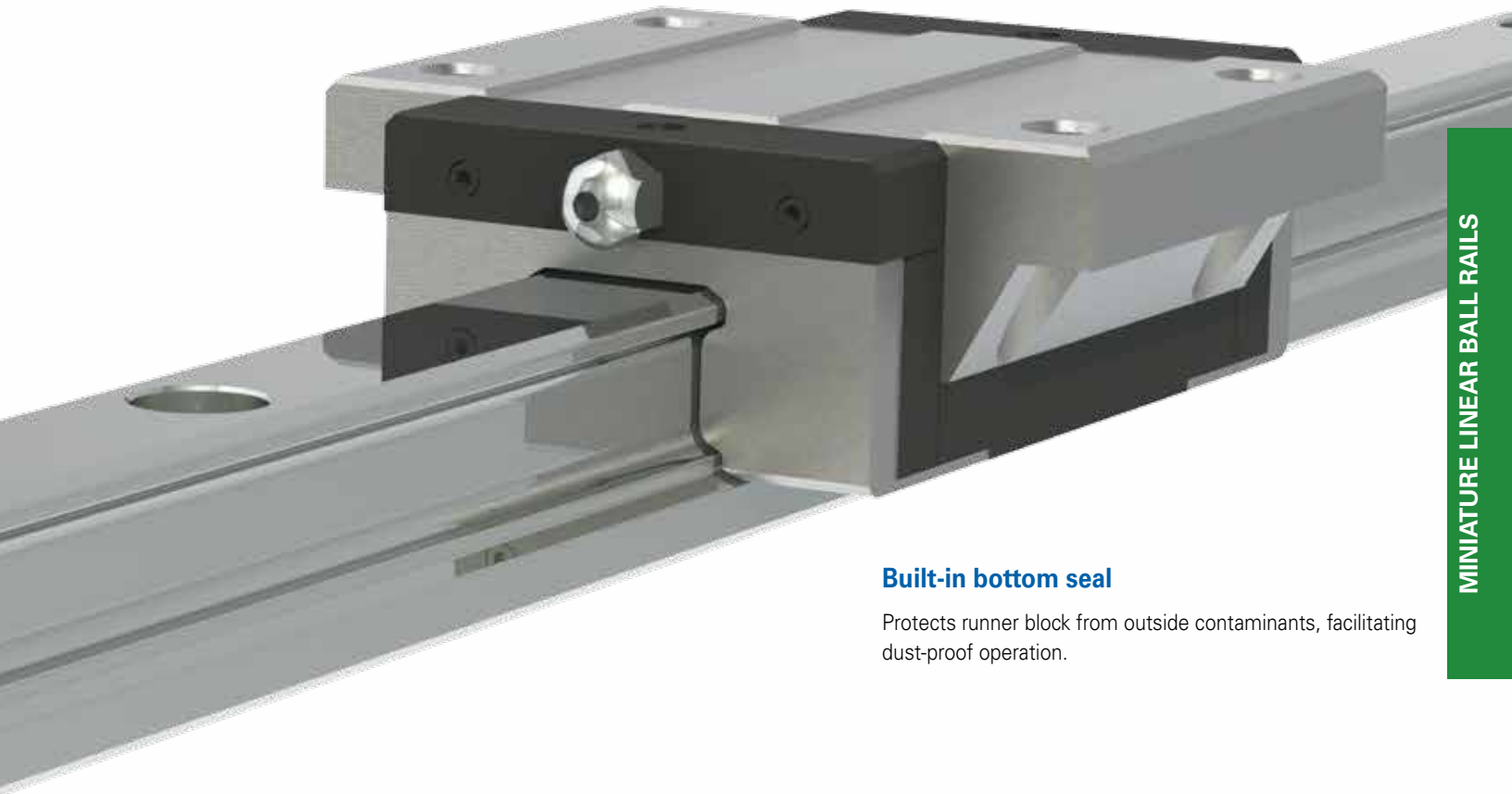

MINIATURE LINEAR BALL RAILS

Built-in bottom seal

Protects runner block from outside contaminants, facilitating dust-proof operation.

Lubrication storage design

Environmentally-friendly system requires less lubricant.

Material

Regardless of series, MR miniature linear guides use stainless steel processed material.

PRODUCT INTRODUCTION NEW DESIGN

EMBEDDED INVERSE HOOK DESIGN FOR REINFORCED MECHANICAL INTEGRATION

When the runner block is in motion and changing direction, the circulating stainless steel balls inside the raceway generate impact force against the plastic end cap. As the demand for rapid motion in the automation industry has increased, Nook has invented a new design to improve high speed running capability. Plastic inverse hooks for miniature linear blocks tightly secure block components to handle the impact force effectively by distributing the applied stress over a large area.

UNIQUE BALL RE-CIRCULATION DESIGN

The stainless steel ball re-circulation hole and channel constructs are fully sealed by plastic frame and end caps. The simple structure substantially reduces contact surface between steel ball and metal, thus reduces noise significantly. The lubrication oil storage embedded in the circulation channel significantly extends the re-lubricating interval, extends life and reduces preventative maintenance.

Suitable for:

- High speed belt driven mechanism
- High speed carrier design
- Automation linkage between stations.

NMR-EE SERIES STAINLESS STEEL REINFORCED PLATES ENSURE HIGH ROBUSTNESS

Runner blocks are equipped with two stainless steel plates which reinforce the end-cap from end to end. This sturdier design supports higher running speeds. The plates can also function as scrapers to facilitate smooth travel.

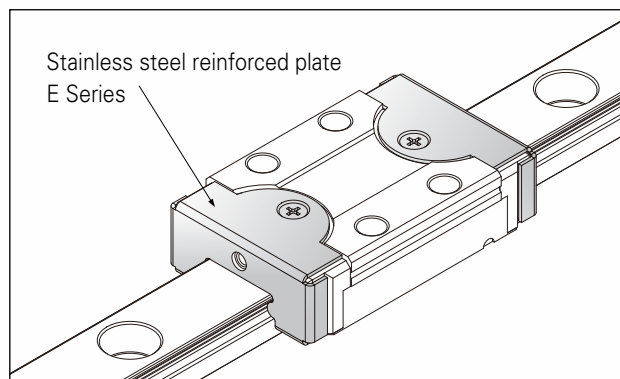

LUBRICATION STORAGE DESIGN

Lubricant injection holes are featured at both ends of the runner block. As the balls circulate during movement of the block, the stainless steel balls carry lubrication oil to the raceway, thus efficiently lubricating the balls and the oil raceway, and achieving long-term, maintenance-free linear motion. This design also provides superb lubricating ability for short stroke movement. A newly-invented embedded lubrication pad design provides a selection of options for machine design.

(3M /W, 5M /W, 7M /W, 9M /W, 12M /W, 15M /W)

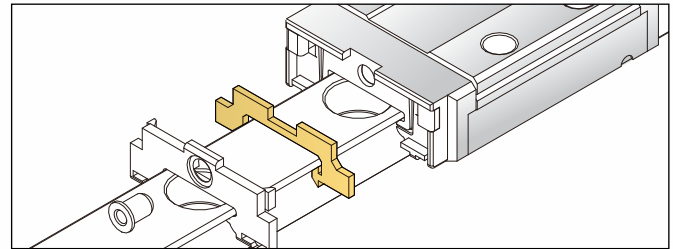

HIGH LOAD AND HIGH MOMENT CAPACITY

The NMR Miniature Linear Guide series is designed using two rows of recirculating balls. The design uses a Gothic profile with a 45° contact angle to achieve equal load capacity in all directions. Within the restriction of limited space, larger stainless steel balls are used to enhance the load and torsion resistance capacity.

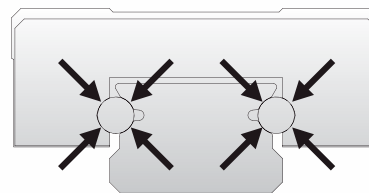

Nook linear guides (indicated with the thick black line to the right) provide greater surface contact as compared to competing products (indicated with the thin red-dotted line at right) when comparing same widths rails.

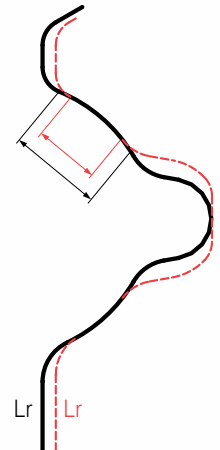

DUST PROOF DESIGN

Our standard design comes equipped with an end seal that effectively restricts dust contamination and prolongs lubrication, ensuring longer product life. Specially-designed low friction seal lips do not affect running smoothness.

TECHNICAL INFORMATION

ACCURACY

NMR Miniature Linear Guide series have three accuracy classes: P, H, and N.

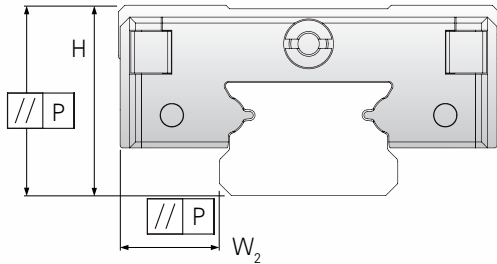

TABLE OF ACCURACY

Accuracy classes (µm)		Precision	High	Normal
		P	H	N*
Tolerance of dimension height H	H	±10	±20	±40
Variation of height for different runner block on the same position of rail	ΔH	7	15	25
Tolerance of dimension width W	W ₂	±15	±25	±40
Variation of width for different runner block on same position of rail	ΔW ₂	10	20	30

* Stocked

SPEED

The maximum speed for the standard NMR-SS/ZZ type is:
Velocity_{max} = 3 m/s

Maximum acceleration:
Acceleration_{max} = 250 m/s²
 (if the preload V0, capable of reaching 40 m/s²)

The maximum speed for the standard NMR-EE/EZ type is:
Velocity_{max} = 5 m/s

Maximum acceleration:
Acceleration_{max} = 300 m/s²
 (if the preload V0, capable of reaching 60 m/s²)

Accuracy of the running parallelism

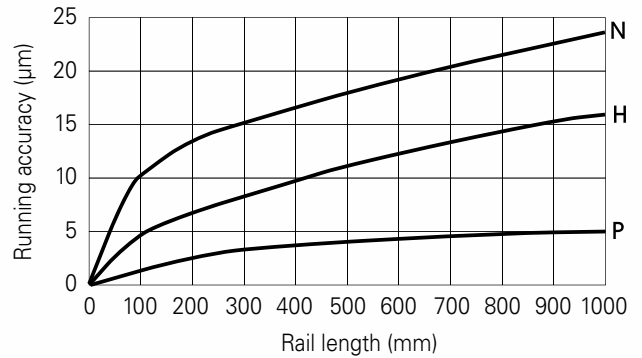

PRELOAD CLASSES

The NMR Miniature Linear Guide series have three degrees of preload: V0, Vs and V1 (as described in the Table of Preload below). Preload can enhance stiffness, precision, and torsion resistance, but will negatively affect life and friction.

TABLE OF PRELOAD

Preload type	Model code	Clearance (µm)						Application
		3	5	7	9	12	15	
Clearance*	V0	3 - 0	3 - 0	4 - 0	4 - 0	5 - 0	6 - 0	Very smooth
Standard	Vs	1 - 0	1 - 0	2 - 0	2 - 0	2 - 0	3 - 0	Smooth and precision
Light preload	V1	0 - -0.5	0 - -1	0 - -3	0 - -4	0 - -5	0 - -6	High rigidity Minimize vibration High precision Load balance

* Stocked

TECHNICAL INFORMATION

LIFE

Static Load Rating C

For the static load traveling along the acting direction, the maximum calculated stress at the rolling elements and the raceway, by a curvature radius ≤ 0.52 , is 4200MPa and, by a curvature radius ≥ 0.6 , is 4600MPa.

To convert 100kl of life to 50kl of live, use the following formula:

$$C_{50} = 1.26 \times C_{100}$$

Note: Under such stress, a permanent total deformation is generated at this contact point corresponding to about 0.0001 times the rolling element diameter (ISO 14728-2).

Static Moment Ratings M

For C, C₀, M of each model refer to dimensional table. Nook Precision Profile Rails have the same dynamic load capacity in four directions: radial, reverse-radial and bi-lateral.

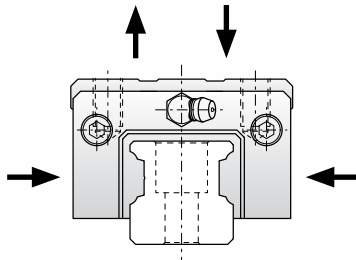

Static Safety Factor

Generally, the maximum permitted static load on the runner block is equivalent to static load ratings C₀. However, in repeated linear motion applications, unexpected load is caused by the inertia when the system starts or stops. Therefore, the safety factor f_s should be calculated in order to determine the allowable load.

Where:

$$\frac{C_0}{P_0} \geq f_s$$

C₀ = static load ratings
P₀ = equivalent load (static load, impact load)
f_s = static safety factor

The value of f_s for general use is indicated in the table below:

OPERATING CONDITION	Minimum f _s
Normal operation	1~3
Smooth running required	3~4
Operation with impact or vibration	4~5

Dynamic Load Rating C

When the dynamic loads are applied to normal load zones with constant magnitude and direction, theoretically, the rate life of a linear guide can reach 100 km of travel distance (ISO 14728-1).

Rating Life L

The dynamic rating is based on 100km of life. When the standard of 50km travel distance is used, the dynamic load rating will exceed the value based on the standard ISO 14728-1 by 20% or more.

$$L = 100 \times \left(\frac{C}{P}\right)^3$$

Where:

L = expected life
C = basic load ratings
P = equivalent load

Where the stroke (m) and the number of cycles per minute n₁ (cpm) are constant, the rated fatigue life L_n (hr) is calculated by the following formula.

$$L_n = \frac{100 \times 10^3}{120 \times l_s \times n_1} \times \left(\frac{C}{P}\right)^3$$

Where:

L_n = expected Life (hr)
l_s = stroke length (m)
n₁ = number of strokes per minute

EQUIVALENT DYNAMIC LOAD AND SPEED

If the load and speed are not constant, each actual load and speed must be taken into account and both will influence the life.

Equivalent Dynamic Load

If there is a change in load only, the equivalent dynamic load can be calculated according to the following formula:

$$P = 3 \sqrt{\frac{q_1 \times F_1^3 + q_2 \times F_2^3 + \dots + q_n \times F_n^3}{100}}$$

Where:

P = Equivalent dynamic load (N)
q_n = Percentage of stroke (%)
F_n = Discrete load steps (N)

Combined Dynamic Load

If the linear guide takes on load from an arbitrary angle, it's equivalent dynamic load rating is calculated using the following formula:

$$P = F_x + F_y$$

Where:

P = Equivalent dynamic load (N)
F_y = External dynamic load, vertical N
F_x = External dynamic load, horizontal N

Equivalent Speed

If there is a change in speed only, the equivalent speed can be calculated using the following formula:

$$v = \frac{q_1 \times v_1 + q_2 \times v_2 + \dots + q_n \times v_n}{100}$$

Where:

- P = Equivalent dynamic load (N)
- q_n = Percentage of stroke (%)
- v = Average speed (m/min)
- v_n = Discrete speed steps (m/min)

If there are changes in both load and speed, the equivalent dynamic load can be calculated using the following formula:

$$P = \sqrt[3]{\frac{q_1 \times v_1 \times F_1^3 + q_2 \times v_2 \times F_2^3 + \dots + q_n \times v_n \times F_n^3}{100}}$$

Combining Linear Forces with Moment Loads

If both load and moment act on the linear guide, the equivalent dynamic load can be calculated by the formula.

$$P = F + M \times \frac{C_0}{M_0}$$

Where:

- P = Equivalent dynamic load (N)
- F_n = External dynamic load N
- M = Static moment Nm
- M₀ = Static moment rating Nm

According to ISO 14728-1, the equivalent load(P) shall not exceed ½C.

FRICITION

The NMR miniature linear guide series is characterized with light starting friction and low, stable and consistent friction during operation.

$$F_m = \mu \times F$$

Where:

- F = Load (N)
- F_m = Friction (N)

NMR Miniature linear Guide series friction factor is approximately μ=0.002-0.003.

Source of friction

- Resistance of the sealing system
- Resistance of the collision between the balls during operation
- Resistance from the collision between the balls and the return path
- Rolling resistance of the balls in the gothic arch load zone
- Resistance from the churning of the lubricant in the runner block
- Resistance from the penetrated contaminant

FRICITION WITH END SEAL UNDER LUBRICATION

NMR size	Friction with End Seal (N _{max}) (under lubrication)	
	M	W
2	0.08	0.2
3	0.08	0.2
5	0.08	0.2
7	0.1	0.4
9	0.1	0.8
12	0.4	1.0
15	1.0	1.0

SEALING DESIGN

The NMR miniature linear guide series adopts end seals on both ends of the runner block. Optional side seals build an all-around closed sealing system.

OPERATING TEMPERATURE

The NMR miniature linear guide can operate in a range of temperatures from -40°C - 80°C. For short term operation it can reach up to 100°C.

TECHNICAL INFORMATION

LUBRICATION

The loaded rolling elements and the raceway will be separated at the contact zone by a thin layer of oil.

The effective lubrication will:

- Reduce friction
- Prevent corrosion
- Reduce wear
- Dissipate heat and increase service life

Oil Lubrication

Nook recommends LBL1 (see page 198). A lubricant formulated for rolling friction should be used with Nook Linear Bearings. In applications where operating speeds are low and loads are light, Nook linear bearings can be used without lubrication at a reduced life. However, to protect the highly polished bearing surfaces from corrosion and wear, a lubricant is recommended.

LUBRICATION INTERVAL

Speed, load, stroke length, and operating environment affect re-lubrication interval. A safe lubrication interval can only be obtained by practical observation.

Lubrication interval shall not exceed one year. Lubrication can be applied through the injection hole on both ends of the block by using a special injector available from Nook.

- Lubrication shall be applied before lubricant is contaminated or changes color
- Amount of lubricant is 1/2 of the first lubrication. If lubricant oil is applied, add until oil over flows (see Table 1 below)
- Lubrication shall be applied under operation temperature. Move block back and forth while adding lubricant to ensure even distribution. **Water based lubricant oil should not be applied to the block or rail**
- If the stroke is smaller than one time or greater than 10 times the block steel body length, the re-lubrication interval shall be shortened

TABLE 1

Model code	First lube (cm ³)	Model Code	First lube(cm ³)
3MN	0.02	2WL/3WN	0.03
3ML	0.03	3WL	0.04
5MN	0.03	5WN	0.04
5ML	0.04	5WL	0.05
7MN	0.12	7WN	0.19
7ML	0.16	7WL	0.23
9MN	0.23	9WN	0.30
9ML	0.30	9WL	0.38
12MN	0.41	12WN	0.52
12ML	0.51	12WL	0.66
15MN	0.78	15WN	0.87
15ML	1.05	15WL	1.11

Caution

- For the ZZ and EZ series:
 1. Block contains lubricant which can be directly installed on the machine with no need to be washed.
 2. If washing the blocks, please do not soak the block in the lubricant before both the detergent of lubrication storage area and Cleaning Naphtha are totally dry. The block is ready for installation only on the condition that the lubrication storage area is full of the lubricant.
- The linear guide must be lubricated for protection before the first use. Contamination of any kind should be avoided
- The runner block should be moved back and forth during lubrication
- Generally, the lubricant can be added onto rail raceway
- The lubricant can be injected into the lubrication holes on either end of the runner block
- A thin coating of lubricant should be maintained on the surface of the rail raceway at all times
- Re-lubricate before contamination or discoloration of the lubricant occurs
- Notify Nook Engineering when used in acidic, alkaline or clean room applications
- Contact Nook Engineering for lubrication assistance if the runner block is used in a wall mount configuration

LUBRICATION APPLICATOR

When reordering lubrication applicator, please specify appropriate part number and needle:

LUB – LBL1 – XXX
 XXX=Needle model
 Part No.



MODEL CODE	NEEDLE
5M/5W	21G
7M	20G
7W	19G
9M/9W	18G
12M/12W	18G
15M/15W	15G

Note: Applicator does not come prefilled. Capacity = 10ml. LBL1 is the recommended lubricant. Other lubricants are available.

Grease Lubrication

When lubricant grease is required, synthetic oil-based lithium soap grease with a viscosity between ISO VG32-100 is recommended.

LINEAR GUIDANCE

MINIATURE LINEAR BALL RAILS

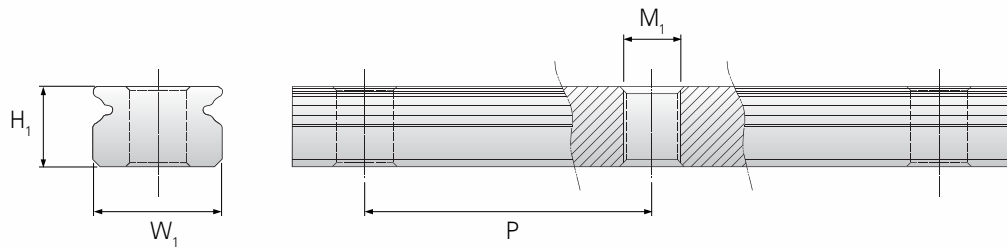

UPWARD MOUNTING STANDARD NMRU-M SERIES

RAIL DIMENSIONS (mm)				
Model	H ₁	W ₁	P	M ₁
NMRU 3M	2.6	3	10	M1.6 × 0.35
NMRU 5M	3.5	5	15	M3 × 0.5
NMRU 7M	4.7	7	15	M3 × 0.5
NMRU 9M	5.5	9	20	M4 × 0.7
NMRU 12M	7.5	12	25	M4 × 0.7
NMRU 15M	9.5	15	40	M4 × 0.7

UPWARD MOUNTING WIDE NMRU-W SERIES

RAIL DIMENSIONS (mm)				
Model	H ₁	W ₁	P	M ₁
NMRU 3W	2.7	6	15	M3 × 0.5
NMRU 5W	4	10	20	M3 × 0.5
NMRU 7W	5.2	14	30	M4 × 0.7
NMRU 9W	7.5	18	30	M4 × 0.7
NMRU 12W	8.5	24	40	M5 × 0.8
NMRU 15W	9.5	42	40	M5 × 0.8

INSTALLATION ILLUSTRATION

REFERENCE SURFACE HEIGHT AND CHAMFERED

To avoid any interference, the corner of the reference edge should have a chamfer. If not, please refer to the following table for the height of the reference edge corner and the height of the reference edge.

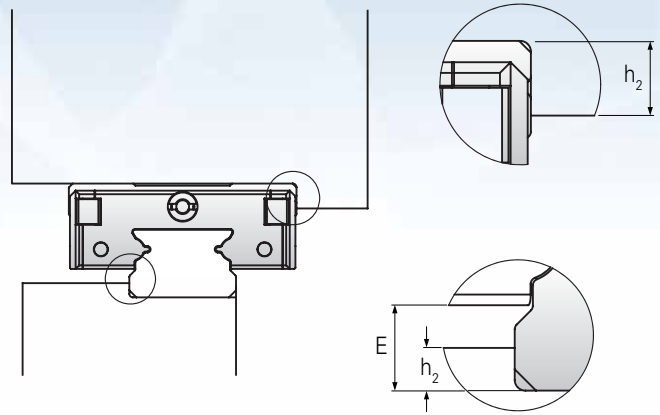

HEIGHT AND CHAMFERED THE REFERENCE SURFACE

DIMENSIONS	h_1	$r_{1,max}$	h_2	$r_{2,max}$	E
3M SS	0.5	0.2	1.5	0.3	1
3M SU/ZU	0.5	0.2	1.5	0.3	0.9
5M SS	1.2	0.2	1.9	0.3	1.5
5M SU/ZU	1	0.2	1.9	0.3	1.4
5M EE/EZ	0.6	0.2	1.9	0.3	1.1
5M SUE/ZUE	0.5	0.2	1.9	0.3	1
7M SS/ZZ	1.2	0.3	2.8	0.3	1.5
7M SU/ZU	0.8	0.3	2.8	0.3	1.3
9M SS/ZZ	1.5	0.3	3	0.3	2.2
9M SU/ZU	1.5	0.3	3	0.3	2
9M EE/EZ	1.2	0.3	3	0.3	1.7
9M EU/UZ	1	0.3	3	0.3	1.4
9M SUE/ZUE	1	0.3	3	0.3	1.5
12M SS/ZZ	2.5	0.5	4	0.5	3
12M SU/ZU	2.3	0.5	4	0.5	2.8
12M EE/EZ	1.5	0.5	4	0.5	2.3
12M EU/ZU	1.5	0.5	4	0.5	2
12M SUE/ZUE	1.5	0.5	4	0.5	2.1
15M SS/ZZ	2.5	0.5	4.5	0.5	4
15M SU/ZU	2.5	0.5	4.5	0.5	3.7
15M EE/EZ	2.5	0.5	4.5	0.5	3.2
15M EU/UZ	2	0.5	4.5	0.5	2.9
15M SUE/ZUE	2.4	0.5	4.5	0.5	2.9

DIMENSIONS	h_1	$r_{1,max}$	h_2	$r_{2,max}$	E
2WL SS/ZZ	0.5	0.2	1.7	0.3	1
2WL SU/ZU	0.5	0.2	1.7	0.3	0.9
2W EE/EZ	0.6	0.2	1.5	0.3	0.7
2W SUE/ZUE	0.4	0.2	1.5	0.3	0.6
3W SS	0.7	0.2	1.7	0.3	1
3W SU/ZU	0.6	0.2	1.7	0.3	0.9
5W SS	1.2	0.2	2	0.3	1.5
5W SU/ZU	0.9	0.2	2	0.3	1.4
7W SS/ZZ	1.2	0.3	2.8	0.3	2
7W SU/ZU	1.3	0.3	2.8	0.3	1.8
7W EE/EZ	1	0.3	2.8	0.3	1.5
7W SUE/ZUE	0.9	0.3	2.8	0.3	1.4
9W SS/ZZ	1.5	0.3	3	0.3	4.2
9W SU/ZU	2.5	0.3	3	0.3	3.2
9W EE/EZ	2	0.3	3	0.3	2.8
9W EU/UZ	1.5	0.3	3	0.3	2.5
9W SUE/ZUE	2	0.3	3	0.3	2.6
12W SS/ZZ	2.5	0.5	4	0.5	3.9
12W SU/ZU	2.5	0.5	4	0.5	3.6
12W EE/EZ	2.5	0.5	4	0.5	3.3
15W SS/ZZ	2.5	0.5	4.5	0.5	4
15W SU/ZU	2.5	0.5	4.5	0.5	3.7
15W EE/EZ	2.5	0.5	4.5	0.5	3.2
15W EU/UZ	2	0.5	4.5	0.5	2.9
15W SUE/ZUE	2	0.5	4.5	0.5	2.9

THE MOUNTING SURFACE

Surface roughness – the mounting surface should be ground or fine milled to reach a surface roughness Ra1.6.

SCREW TIGHTENING TORQUE (Nm)

Screw Grade 12.9	Steel	Cast Iron	Non Iron Metal
M2	0.6	0.4	0.3
M3	1.8	1.3	1
M4	4	2.5	2

GEOMETRIC AND POSITIONAL ACCURACY OF THE MOUNTING SURFACE

Inaccurate mounting surfaces will affect the operational accuracy of the linear guide. The rating lifetime will also be shortened. Insure the mounting surface height differential is greater than the values calculated by the formulas below.

$$e_1 \text{ (mm)} = b \text{ (mm)} \times f_1 \times 10^{-4}$$

$$e_2 \text{ (mm)} = d \text{ (mm)} \times f_2 \times 10^{-5}$$

$$e_3 \text{ (mm)} = f_3 \times 10^{-3}$$

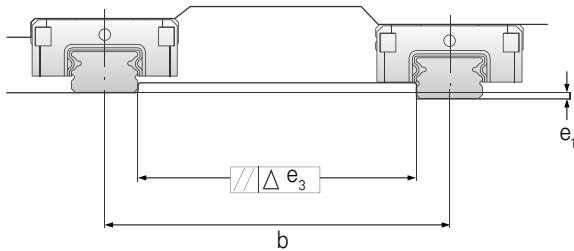

REFERENCE SURFACE

Rail: Both sides of the track rail can be the reference surface without any special marking.

Block: Reference edge is opposite to the groove marking side.

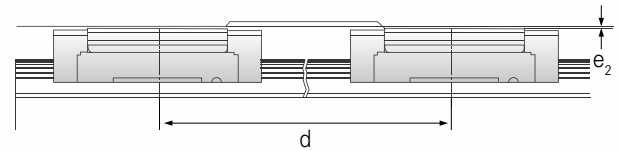

DIMENSION	Preload V0/VS			Preload V1		
	f ₁	f ₂	f ₃	f ₁	f ₂	f ₃
3MN	4	9	2	3	9	1
5MN	4	8	2	2	8	2
7MN	5	11	4	3	10	3
9MN	5	11	6	4	10	4
12MN	6	13	8	4	12	6
15MN	7	11	12	5	10	8
3ML	4	5	2	3	5	1
5ML	3	5	2	2	5	1
7ML	4	6	4	3	6	3
9ML	5	7	5	3	7	4
12ML	5	8	8	3	7	5
15ML	7	8	11	4	8	7

DIMENSION	Preload V0/VS			Preload V1		
	f ₁	f ₂	f ₃	f ₁	f ₂	f ₃
2WL	4	5	2	3	5	1
3WN	2	5	2	4	3	1
5WN	2	5	2	1	3	1
7WN	2	6	4	2	4	3
9WN	2	7	6	2	5	4
12WN	3	8	8	2	5	5
15WN	2	9	11	1	6	7
3WL	2	3	1	1	2	1
5WL	2	3	2	1	2	1
7WL	2	4	4	1	3	3
9WL	2	5	5	2	3	3
12WL	2	5	7	2	3	5
15WL	2	5	10	1	4	7

REFERENCE NUMBER SYSTEM

ASSEMBLY

NMR U 15 M N EE 2 V1 N - 310 - 15 - 15 II JC3

PRODUCT TYPE

NMR = Miniature Linear Guide

RAIL

Special U = Upward Screwing Rail No Mark = Standard Rail — **U 15 M**

Dimension The width of Rail ex. = 2, 3, 5, 7, 9, 12, 15

Type M = Standard W = Wide

BLOCK TYPE

L = Long, N = Standard

SEAL TYPE

SS = End Seal

ZZ = End Seal, Lubrication Storage

SU = End Seal, Bottom Seal*

ZU = End Seal, Bottom Seal, Lubrication Storage*

EE = End Seal, Reinforcement Plate

EZ = End Seal, Lubrication Storage,
Reinforcement Plate

* Stocked

EU = End Seal, Reinforcement Plate, Stainless
Bottom Seal

UZ = End Seal, Reinforcement Plate, Stainless
Bottom Seal, Lubrication Storage

SUE = End Seal, Reinforcement Plate,
Bottom Seal

ZUE = End Seal, Reinforcement Plate,
Bottom Seal, Lubrication Storage

QUANTITY OF RUNNER BLOCK

CLASSES

Preload V0 = Clearance VS = Standard V1 = Light Preload

Accuracy N = Normal P = Precision H = High

LENGTH

Length (mm) **310 - 15 - 15**

End Hole Pitch (mm)

Starting Hole Pitch (mm)

NUMBER OF RAILS ON THE SAME MOVING AXIS

CUSTOMIZATION CODE

See Customization Code on the following page.

RAIL ONLY

NMR U 15 M - 310 - 15 - 15

PRODUCT TYPE

NMR = Miniature Linear Guide

RAIL

Special U = Upward Screwing Rail No Mark = Standard Rail

Dimension The width of rail ex. = 2, 3, 5, 7, 9, 12, 15

Type M = Standard W = Wide

LENGTH

Length (mm) **310 - 15 - 15**

End Hole Pitch (mm)

Starting Hole Pitch (mm)

LINEAR GUIDANCE

MINIATURE LINEAR BALL RAILS

RAIL LENGTH

		WIDE RAIL						
Size		2W	3W	5W	7W	9W	12W	15W
Standard Length of one rail (mm)	30	40	50	50	50	70	110	
	40	55	70	80	80	110	150	
	50	70	90	110	110	150	190	
				110	140	140	190	230
				130	170	170	230	270
				150	200	200	270	310
				170	260	260	310	430
					290	290	390	550
						320	470	670
							550	790
Pitch (mm)		10	15	20	30	30	40	40
L ₂ , L ₃ min		3	3	4	3	4	4	4
L ₂ , L ₃ max		5	10	15	25	25	35	35
L _{max}		300	1000	1000	1000	1000	1000	1000

		STANDARD RAIL						
Size		3M	5M	7M	9M	12M	15M	
Standard Length of one rail (mm)	30	40	40	55	70	70		
	40	55	55	75	96	110		
	50	70	70	95	120	150		
			85	85	115	145	190	
			100	100	135	170	230	
					130	155	196	270
						175	220	310
						195	245	350
						275	270	390
						375	320	430
							370	470
							470	550
							570	670
							870	
Pitch (mm)		10	15	15	20	25	40	
L ₂ , L ₃ min		3	3	3	4	4	4	
L ₂ , L ₃ max		5	10	10	20	20	35	
L _{max}		300	1000	1000	1000	1000	1000	

LENGTH OF RAIL

Butt-jointing is required when lengths exceed L_{max}. (For detailed information, please contact Nook technical support)

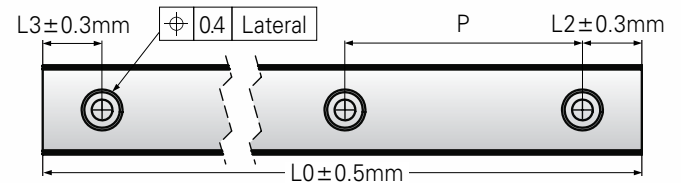

CUSTOMIZATION CODE

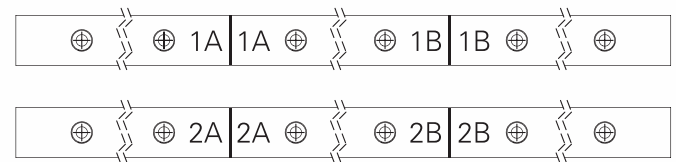

J = Butt-jointing Track Rail

When the required length of the customer's rail exceeds the standard rail length, a butt-joint can be specified. The rail butt-joint indication is marked as illustrated above.

B = Special Process for Block

For special process requirements, please contact Nook Engineering.

C3 or C4 = Plugs For Mounting Holes on Rail

C3 applies to NMR9M, NMR12M, NMR15M, NMR7W & NMR9W rails. C4 applies to NMR12W, NMR15W rails. All rails are shipped with plugs for mounting holes unless otherwise specified.

R = Special Process for Rail

For special process requirements, please contact Nook Engineering

S = Special Straightness for Rail

The straightness of the linear guide rail is specially calibrated by precision fine grinding.

G = Customer Designate Lubricant

According to application environment.

GN = No Lubricant

GC = Low Dust Generation

Suitable for clean room environments.

I = Inspection Report

Please contact Nook Engineering.

STANDARD NMR-M **SU - END SEAL, BOTTOM SEAL**
MN - STANDARD BLOCK LENGTH
ML - LONG BLOCK LENGTH
FOUR TAPPED HOLES

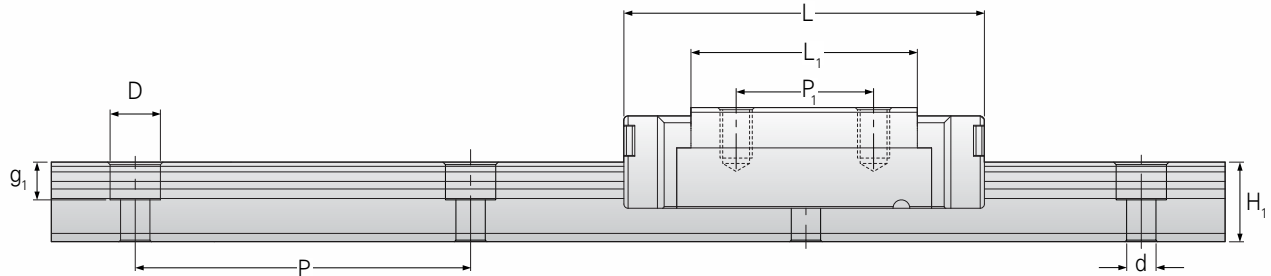





Model	FABRICATE DIMENSION		RAIL DIMENSIONS (mm)				BLOCK DIMENSIONS (mm)					
	Height	Width	W ₁	H ₁	P	D × d × g ₁	Width		Length			
	H	W ₂					W	L	L ₁	h ₂	P ₁	P ₂
NMR 3MN SU	4	2.5	3	2.6	10	M1.6	8	11.7	6.7	3.1	3.5	—
NMR 3ML SU	4	2.5	3	2.6	10	M1.6	8	16	11	3.1	5.5	—
NMR 5MN SU	6	3.5	5	3.5	15	3.5 × 2.4 × 1	12	16	10	4.6	—	8
NMR 5ML SU	6	3.5	5	3.5	15	3.5 × 2.4 × 1	12	19.6	13.5	4.6	7	—
NMR 7MN SU	8	5	7	4.7	15	4.2 × 2.4 × 2.3	17	23.7	14.3	6.7	8	12
NMR 7ML SU	8	5	7	4.7	15	4.2 × 2.4 × 2.3	17	31.2	21.8	6.7	13	12
NMR 9MN SU	10	5.5	9	5.5	20	6 × 3.5 × 3.5	20	30.6	20.5	8	10	15
NMR 9ML SU	10	5.5	9	5.5	20	6 × 3.5 × 3.5	20	40.9	30.8	8	16	15
NMR 12MN SU	13	7.5	12	7.5	25	6 × 3.5 × 4.5	27	35.4	22	10.2	15	20
NMR 12ML SU	13	7.5	12	7.5	25	6 × 3.5 × 4.5	27	47.6	34	10.2	20	20
NMR 15MN SU	16	8.5	15	9.5	40	6 × 3.5 × 4.5	32	43	27	12.3	20	25
NMR 15ML SU	16	8.5	15	9.5	40	6 × 3.5 × 4.5	32	60	44	12.3	25	25

Load capacities are calculated according to ISO 14728. To compare the rating life definition and the load capacities: $C_{50} = 1.26 \times C_{100}$

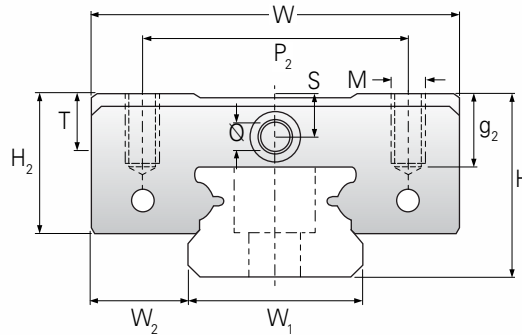
LINEAR GUIDANCE

MINIATURE LINEAR BALL RAILS



BLOCK DIMENSIONS (mm)				BASIC LOAD RATINGS (N)		STATIC MOMENT RATINGS (Nm)			WEIGHT	
M × g ₂	Ø	S	T	Dynamic	Static				Block	Rail
				C ₁₀₀	C ₀	g	g/m			
M1.6 × 1.1	0.3	0.7	1.5	190	310	0.4	0.4	0.6	0.9	53
M2 × 1.1	0.3	0.7	1.5	295	575	1.1	1.1	0.9	1.2	53
M2 × 1.5	0.7	1.3	2	335	550	1	1	1.7	3.5	116
M2.6 × 2.0	0.7	1.3	2	470	900	2.1	2.1	2.4	4	116
M2 × 2.5	1.1	1.6	2.8	890	1,400	3.3	3.3	5.2	8	215
M2 × 2.5	1.1	1.6	2.8	1,310	2,440	7.7	7.7	9	14	215
M3 × 3.0	1.3	2.2	3.3	1,570	2,495	6.4	6.4	11.7	18	301
M3 × 3.0	1.3	2.2	3.3	2,135	3,880	12.4	12.4	18.2	28	301
M3 × 3.5	1.3	3.2	4.3	2,308	3,465	12.9	12.9	21.5	34	602
M3 × 3.5	1.3	3.2	4.3	3,240	5,630	30.2	30.2	34.9	51	602
M3 × 5.5	1.8	3.3	4.3	3,810	5,590	27	27	43.6	61	930
M3 × 5.5	1.8	3.3	4.3	5,350	9,080	63.3	63.3	70	90	930

STANDARD NMR-M **ZU - END SEAL, BOTTOM SEAL, LUBRICATION STORAGE**
MN - STANDARD BLOCK LENGTH
ML - LONG BLOCK LENGTH
FOUR TAPPED HOLES

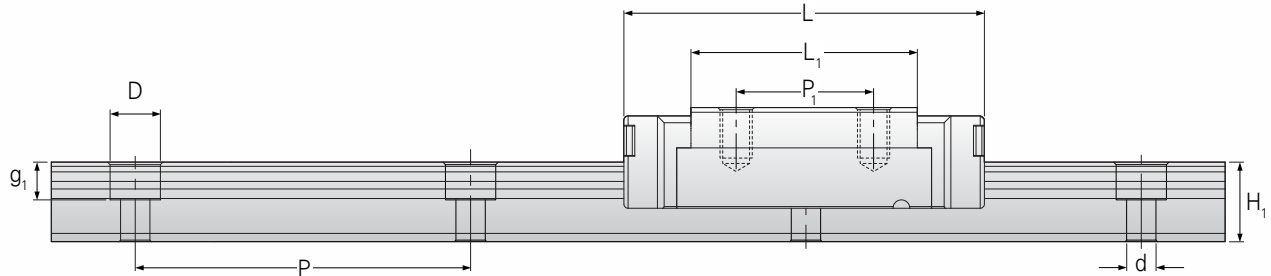





Model	FABRICATE DIMENSION		RAIL DIMENSIONS (mm)				BLOCK DIMENSIONS (mm)					
	Height	Width	W ₁	H ₁	P	D × d × g ₁	Width		Length			
	H	W ₂					W	L	L ₁	h ₂	P ₁	P ₂
NMR 3MN ZU	4	2.5	3	2.6	10	M1.6	8	11.7	6.7	3.1	3.5	—
NMR 3ML ZU	4	2.5	3	2.6	10	M1.6	8	16	11	3.1	5.5	—
NMR 5MN ZU	6	3.5	5	3.5	15	3.5 × 2.4 × 1	12	16	10	4.6	—	8
NMR 5ML ZU	6	3.5	5	3.5	15	3.5 × 2.4 × 1	12	19.6	13.5	4.6	7	—
NMR 7MN ZU	8	5	7	4.7	15	4.2 × 2.4 × 2.3	17	23.7	14.3	6.7	8	12
NMR 7ML ZU	8	5	7	4.7	15	4.2 × 2.4 × 2.3	17	31.2	21.8	6.7	13	12
NMR 9MN ZU	10	5.5	9	5.5	20	6 × 3.5 × 3.5	20	30.6	20.5	8	10	15
NMR 9ML ZU	10	5.5	9	5.5	20	6 × 3.5 × 3.5	20	40.9	30.8	8	16	15
NMR 12MN ZU	13	7.5	12	7.5	25	6 × 3.5 × 4.5	27	35.4	22	10.2	15	20
NMR 12ML ZU	13	7.5	12	7.5	25	6 × 3.5 × 4.5	27	47.6	34	10.2	20	20
NMR 15MN ZU	16	8.5	15	9.5	40	6 × 3.5 × 4.5	32	43	27	12.3	20	25
NMR 15ML ZU	16	8.5	15	9.5	40	6 × 3.5 × 4.5	32	60	44	12.3	25	25

Load capacities are calculated according to ISO 14728. To compare the rating life definition and the load capacities: $C_{50} = 1.26 \times C_{100}$

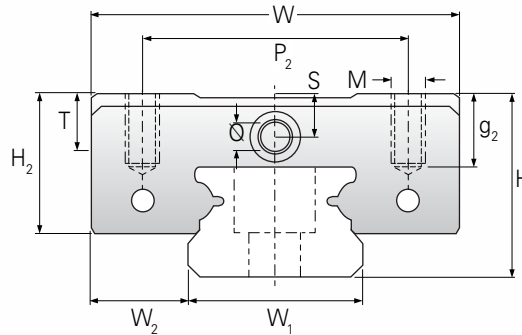
LINEAR GUIDANCE

MINIATURE LINEAR BALL RAILS



BLOCK DIMENSIONS (mm)				BASIC LOAD RATINGS (N)		STATIC MOMENT RATINGS (Nm)			WEIGHT	
$M \times g_2$	\emptyset	S	T	Dynamic	Static				Block	Rail
				C_{100}	C_0	g	g/m			
M1.6 × 1.1	0.3	0.7	1.5	190	310	0.4	0.4	0.6	0.9	53
M2 × 1.1	0.3	0.7	1.5	295	575	1.1	1.1	0.9	1.2	53
M2 × 1.5	0.7	1.3	2	335	550	1	1	1.7	3.5	116
M2.6 × 2.0	0.7	1.3	2	470	900	2.1	2.1	2.4	4	116
M2 × 2.5	1.1	1.6	2.8	890	1,400	3.3	3.3	5.2	8	215
M2 × 2.5	1.1	1.6	2.8	1,310	2,440	7.7	7.7	9	14	215
M3 × 3.0	1.3	2.2	3.3	1,570	2,495	6.4	6.4	11.7	18	301
M3 × 3.0	1.3	2.2	3.3	2,135	3,880	12.4	12.4	18.2	28	301
M3 × 3.5	1.3	3.2	4.3	2,308	3,465	12.9	12.9	21.5	34	602
M3 × 3.5	1.3	3.2	4.3	3,240	5,630	30.2	30.2	34.9	51	602
M3 × 5.5	1.8	3.3	4.3	3,810	5,590	27	27	43.6	61	930
M3 × 5.5	1.8	3.3	4.3	5,350	9,080	63.3	63.3	70	90	930

STANDARD NMR-M **SS - END SEAL**
MN - STANDARD BLOCK LENGTH
ML - LONG BLOCK LENGTH
FOUR TAPPED HOLES

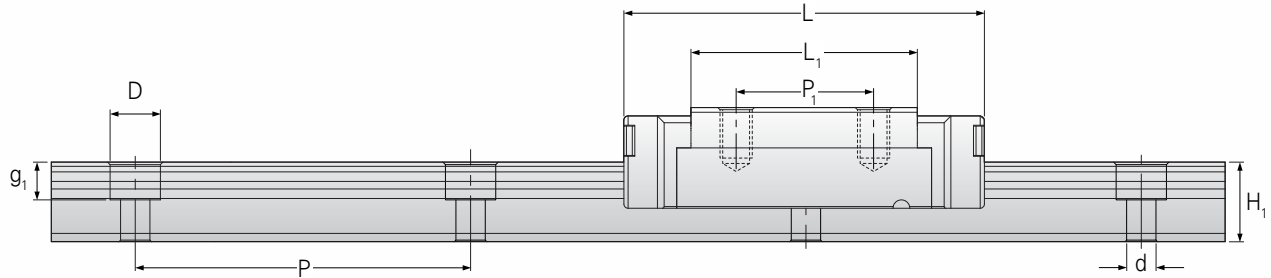





Model	FABRICATE DIMENSION		RAIL DIMENSIONS (mm)				BLOCK DIMENSIONS (mm)					
	Height	Width	W ₁	H ₁	P	D × d × g ₁	Width		Length			
	H	W ₂					W	L	L ₁	h ₂	P ₁	P ₂
NMR 3MN SS	4	2.5	3	2.6	10	M1.6	8	11.7	6.7	3.1	3.5	—
NMR 3ML SS	4	2.5	3	2.6	10	M1.6	8	16	10	3.1	5.5	—
NMR 5MN SS	6	3.5	5	3.5	15	3.5 × 2.4 × 1	12	16	11	4.6	—	8
NMR 5ML SS	6	3.5	5	3.5	15	3.5 × 2.4 × 1	12	19.6	13.5	4.5	7	—
NMR 7MN SS	8	5	7	4.7	15	4.2 × 2.4 × 2.3	17	23.7	14.3	6.5	8	12
NMR 7ML SS	8	5	7	4.7	15	4.2 × 2.4 × 2.3	17	31.2	21.8	6.5	13	12
NMR 9MN SS	10	5.5	9	5.5	20	6 × 3.5 × 3.5	20	30.6	20.5	7.8	10	15
NMR 9ML SS	10	5.5	9	5.5	20	6 × 3.5 × 3.5	20	40.9	30.8	7.8	16	15
NMR 12MN SS	13	7.5	12	7.5	25	6 × 3.5 × 4.5	27	35.4	22	10	15	20
NMR 12ML SS	13	7.5	12	7.5	25	6 × 3.5 × 4.5	27	47.6	34	10	20	20
NMR 15MN SS	16	8.5	15	9.5	40	6 × 3.5 × 4.5	32	43	27	12	20	25
NMR 15ML SS	16	8.5	15	9.5	40	6 × 3.5 × 4.5	32	60	44	12	25	25

Load capacities are calculated according to ISO 14728. To compare the rating life definition and the load capacities: $C_{50} = 1.26 \times C_{100}$

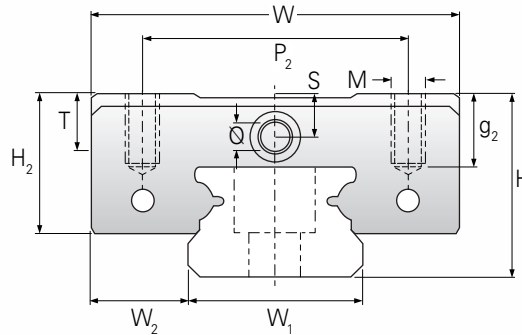
LINEAR GUIDANCE

MINIATURE LINEAR BALL RAILS



BLOCK DIMENSIONS (mm)				BASIC LOAD RATINGS (N)		STATIC MOMENT RATINGS (Nm)			WEIGHT	
$M \times g_2$	\varnothing	S	T	Dynamic	Static				Block	Rail
				C_{100}	C_0	g	g/m			
M1.6 × 1.1	0.3	0.7	1.5	190	310	0.4	0.4	0.6	0.9	53
M2 × 1.1	0.3	0.7	1.5	295	575	1.1	1.1	0.9	1.2	53
M2 × 1.5	0.7	1.3	2	335	550	1	1	1.7	3.5	116
M2.6 × 2.0	0.7	1.3	2	470	900	2.1	2.1	2.4	4	116
M2 × 2.5	1.1	1.6	2.8	890	1,400	3.3	3.3	5.2	8	215
M2 × 2.5	1.1	1.6	2.8	1,310	2,440	7.7	7.7	9	14	215
M3 × 3.0	1.3	2.2	3.3	1,570	2,495	6.4	6.4	11.7	18	301
M3 × 3.0	1.3	2.2	3.3	2,135	3,880	12.4	12.4	18.2	28	301
M3 × 3.5	1.3	3.2	4.3	2,308	3,465	12.9	12.9	21.5	34	602
M3 × 3.5	1.3	3.2	4.3	3,240	5,630	30.2	30.2	34.9	51	602
M3 × 5.5	1.8	3.3	4.3	3,810	5,590	27	27	43.6	61	930
M3 × 5.5	1.8	3.3	4.3	5,350	9,080	63.3	63.3	70	90	930

STANDARD NMR-M **ZZ - END SEAL, LUBRICATION STORAGE**
MN - STANDARD BLOCK LENGTH
ML - LONG BLOCK LENGTH
FOUR TAPPED HOLES

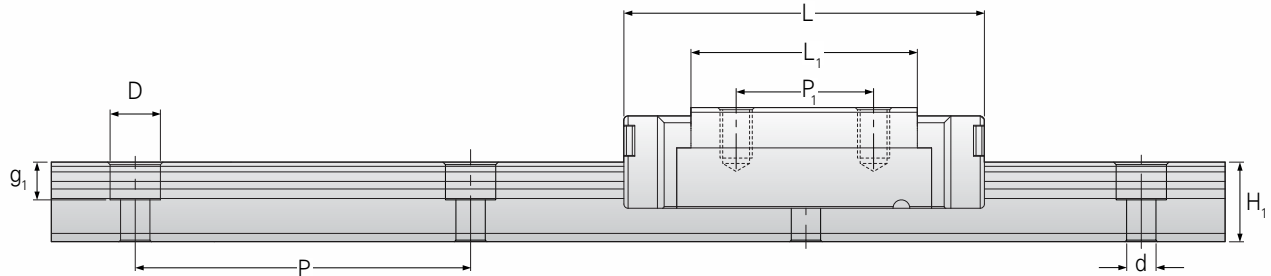





Model	FABRICATE DIMENSION		RAIL DIMENSIONS (mm)				BLOCK DIMENSIONS (mm)					
	Height	Width	W ₁	H ₁	P	D × d × g ₁	Width		Length			
	H	W ₂					W	L	L ₁	h ₂	P ₁	P ₂
NMR 3MN SS	4	2.5	3	2.6	10	M1.6	8	11.7	6.7	3.1	3.5	—
NMR 3ML SS	4	2.5	3	2.6	10	M1.6	8	16	10	3.1	5.5	—
NMR 5MN ZZ	6	3.5	5	3.5	15	3.5 × 2.4 × 1	12	16	10	4.5	—	8
NMR 5ML ZZ	6	3.5	5	3.5	15	3.5 × 2.4 × 1	12	19.6	13.5	4.5	7	—
NMR 7MN ZZ	8	5	7	4.7	15	4.2 × 2.4 × 2.3	17	23.7	14.3	6.5	8	12
NMR 7ML ZZ	8	5	7	4.7	15	4.2 × 2.4 × 2.3	17	31.2	21.8	6.5	13	12
NMR 9MN ZZ	10	5.5	9	5.5	20	6 × 3.5 × 3.5	20	30.6	20.5	7.8	10	15
NMR 9ML ZZ	10	5.5	9	5.5	20	6 × 3.5 × 3.5	20	40.9	30.8	7.8	16	15
NMR 12MN ZZ	13	7.5	12	7.5	25	6 × 3.5 × 4.5	27	35.4	22	10	15	20
NMR 12ML ZZ	13	7.5	12	7.5	25	6 × 3.5 × 4.5	27	47.6	34	10	20	20
NMR 15MN ZZ	16	8.5	15	9.5	40	6 × 3.5 × 4.5	32	43	27	12	20	25
NMR 15ML ZZ	16	8.5	15	9.5	40	6 × 3.5 × 4.5	32	60	44	12	25	25

Load capacities are calculated according to ISO 14728. To compare the rating life definition and the load capacities: $C_{50} = 1.26 \times C_{100}$

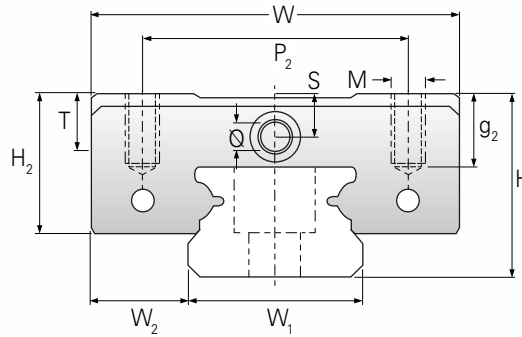
LINEAR GUIDANCE

MINIATURE LINEAR BALL RAILS



BLOCK DIMENSIONS (mm)				BASIC LOAD RATINGS (N)		STATIC MOMENT RATINGS (Nm)			WEIGHT	
$M \times g_2$	\varnothing	S	T	Dynamic	Static				Block	Rail
				C_{100}	C_0				g	g/m
M1.6 × 1.1	0.3	0.7	1.5	190	310	0.4	0.4	0.6	0.9	53
M2 × 1.1	0.3	0.7	1.5	295	575	1.1	1.1	0.9	1.2	53
M2 × 1.5	0.7	1.3	2	335	550	1	1	1.7	3.5	116
M2.6 × 2.0	0.7	1.3	2	470	900	2.1	2.1	2.4	4	116
M2 × 2.5	1.1	1.6	2.8	890	1,400	3.3	3.3	5.2	8	215
M2 × 2.5	1.1	1.6	2.8	1,310	2,440	7.7	7.7	9	14	215
M3 × 3.0	1.3	2.2	3.3	1,570	2,495	6.4	6.4	11.7	18	301
M3 × 3.0	1.3	2.2	3.3	2,135	3,880	12.4	12.4	18.2	28	301
M3 × 3.5	1.3	3.2	4.3	2,308	3,465	12.9	12.9	21.5	34	602
M3 × 3.5	1.3	3.2	4.3	3,240	5,630	30.2	30.2	34.9	51	602
M3 × 5.5	1.8	3.3	4.3	3,810	5,590	27	27	43.6	61	930
M3 × 5.5	1.8	3.3	4.3	5,350	9,080	63.3	63.3	70	90	930

STANDARD NMR-M **SUE - END SEAL, BOTTOM SEAL, REINFORCEMENT PLATE**
ZUE - END SEAL, BOTTOM SEAL, REINFORCEMENT PLATE, LUBRICATION STORAGE
MN - STANDARD BLOCK LENGTH
ML - LONG BLOCK LENGTH
FOUR TAPPED HOLES

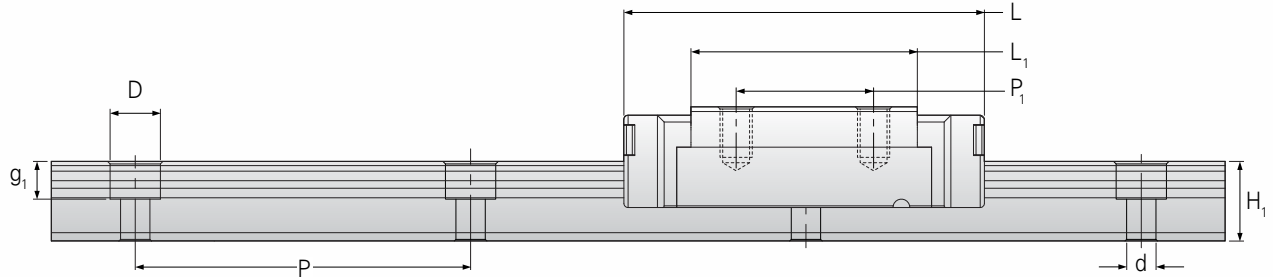

Model	FABRICATE DIMENSION		RAIL DIMENSIONS (mm)				BLOCK DIMENSIONS (mm)					
	Height	Width	W ₁	H ₁	P	D × d × g ₁	Width		Length			
	H	W ₂					W	L	L ₁	h ₂	P ₁	P ₂
NMR 5MN SUE	6	3.5	5	3.5	15	3.5 × 2.4 × 1	12	16.6	10	5	—	8
NMR 5ML SUE	6	3.5	5	3.5	15	3.5 × 2.4 × 1	12	20.2	13.5	5	7	—
NMR 9MN SUE	10	5.5	9	5.5	20	6 × 3.5 × 3.5	20	31.6	20.5	8.5	10	15
NMR 9ML SUE	10	5.5	9	5.5	20	6 × 3.5 × 3.5	20	41.9	30.8	8.5	16	15
NMR 12MN SUE	13	7.5	12	7.5	25	6 × 3.5 × 3.5	27	36.8	22	10.9	15	20
NMR 12ML SUE	13	7.5	12	7.5	25	6 × 3.5 × 3.5	27	49	34	10.9	20	20
NMR 15MN SUE	16	8.5	15	9.5	40	6 × 3.5 × 4.5	32	44.6	27	13.1	20	25
NMR 15ML SUE	16	8.5	15	9.5	40	6 × 3.5 × 4.5	32	61.6	44	13.1	25	25



Model	FABRICATE DIMENSION		RAIL DIMENSIONS (mm)				BLOCK DIMENSIONS (mm)					
	Height	Width	W ₁	H ₁	P	D × d × g ₁	Width		Length			
	H	W ₂					W	L	L ₁	h ₂	P ₁	P ₂
NMR 5MN ZUE	6	3.5	5	3.5	15	3.5 × 2.4 × 1	12	16.6	10	5	—	8
NMR 5ML ZUE	6	3.5	5	3.5	15	3.5 × 2.4 × 1	12	20.2	13.5	5	7	—
NMR 9MN ZUE	10	5.5	9	5.5	20	6 × 3.5 × 3.5	20	31.6	20.5	8.5	10	15
NMR 9ML ZUE	10	5.5	9	5.5	20	6 × 3.5 × 3.5	20	41.9	30.8	8.5	16	15
NMR 12MN ZUE	13	7.5	12	7.5	25	6 × 3.5 × 3.5	27	36.8	22	10.9	15	20
NMR 12ML ZUE	13	7.5	12	7.5	25	6 × 3.5 × 3.5	27	49	34	10.9	20	20
NMR 15MN ZUE	16	8.5	15	9.5	40	6 × 3.5 × 4.5	32	44.6	27	13.1	20	25
NMR 15ML ZUE	16	8.5	15	9.5	40	6 × 3.5 × 4.5	32	61.6	44	13.1	25	25

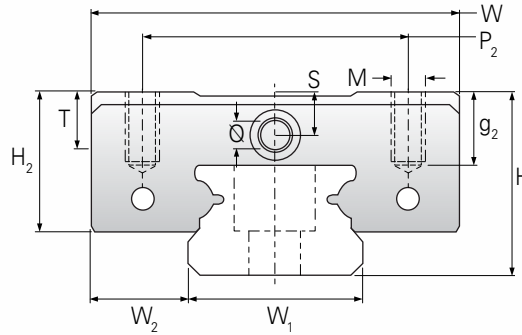

Load capacities are calculated according to ISO 14728. To compare the rating life definition and the load capacities: $C_{50} = 1.26 \times C_{100}$

LINEAR GUIDANCE

MINIATURE LINEAR BALL RAILS



BLOCK DIMENSIONS (mm)				BASIC LOAD RATINGS (N)		STATIC MOMENT RATINGS (Nm)			WEIGHT	
$M \times g_2$	\emptyset	S	T	Dynamic	Static				Block	Rail
				C_{100}	C_0	g	g/m			
M2 × 1.5	0.7	1.3	2	335	550	1	1	1.7	3.5	116
M2.6 × 2.0	0.7	1.3	2	470	900	2.1	2.1	2.4	4	116
M3 × 3.0	1.3	2.2	3.3	1,570	2,495	6.4	6.4	11.7	18	301
M3 × 3.0	1.3	2.2	3.3	2,135	3,880	12.4	12.4	18.2	28	301
M3 × 3.5	1.3	3.2	4.3	2,308	3,465	12.9	12.9	21.5	34	602
M3 × 3.5	1.3	3.2	4.3	3,240	5,630	30.2	30.2	34.9	51	602
M3 × 5.5	1.8	3.3	4.3	3,810	5,590	27	27	43.6	61	930
M3 × 5.5	1.8	3.3	4.3	5,350	9,080	63.3	63.3	70	90	930

BLOCK DIMENSIONS (mm)				BASIC LOAD RATINGS (N)		STATIC MOMENT RATINGS (Nm)			WEIGHT	
$M \times g_2$	\emptyset	S	T	Dynamic	Static				Block	Rail
				C_{100}	C_0	g	g/m			
M2 × 1.5	0.7	1.3	2	335	550	1	1	1.7	3.5	116
M2.6 × 2.0	0.7	1.3	2	470	900	2.1	2.1	2.4	4	116
M3 × 3.0	1.3	2.2	3.3	1,570	2,495	6.4	6.4	11.7	18	301
M3 × 3.0	1.3	2.2	3.3	2,135	3,880	12.4	12.4	18.2	28	301
M3 × 3.5	1.3	3.2	4.3	2,308	3,465	12.9	12.9	21.5	34	602
M3 × 3.5	1.3	3.2	4.3	3,240	5,630	30.2	30.2	34.9	51	602
M3 × 5.5	1.8	3.3	4.3	3,810	5,590	27	27	43.6	61	930
M3 × 5.5	1.8	3.3	4.3	5,350	9,080	63.3	63.3	70	90	930

MINIATURE LINEAR BALL RAILS

STANDARD NMR-M **EE - END SEAL, REINFORCEMENT PLATE**
EZ - END SEAL, REINFORCEMENT PLATE, LUBRICATION STORAGE
MN - STANDARD BLOCK LENGTH
ML - LONG BLOCK LENGTH
FOUR TAPPED HOLES

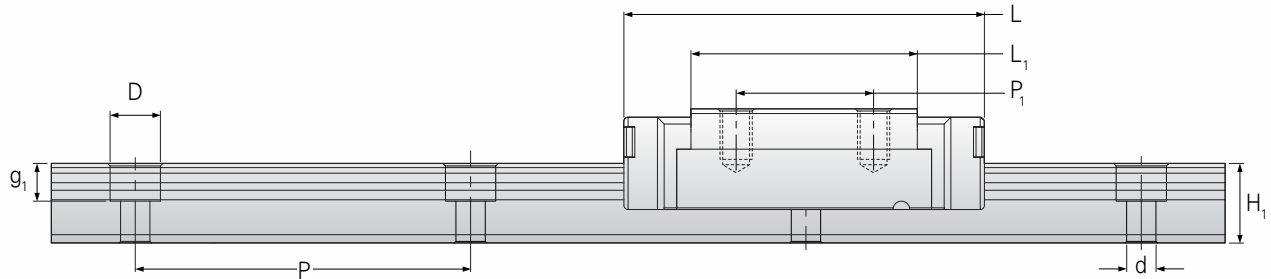

Model	FABRICATE DIMENSION		RAIL DIMENSIONS (mm)				BLOCK DIMENSIONS (mm)					
	Height H	Width W ₂	W ₁	H ₁	P	D × d × g ₁	Width W	Length L	L ₁	h ₂	P ₁	P ₂
NMR 5MN EE	6	3.5	5	3.5	15	3.5 × 2.4 × 1	12	16.6	10	4.9	—	8
NMR 5ML EE	6	3.5	5	3.5	15	3.5 × 2.4 × 1	12	20.2	13.5	4.9	7	—
NMR 9MN EE	10	5.5	9	5.5	20	6 × 3.5 × 3.5	20	31.6	20.5	8.3	10	15
NMR 9ML EE	10	5.5	9	5.5	20	6 × 3.5 × 3.5	20	41.9	30.8	8.3	16	15
NMR 12MN EE	13	7.5	12	7.5	25	6 × 3.5 × 3.5	27	36.8	22	10.7	15	20
NMR 12ML EE	13	7.5	12	7.5	25	6 × 3.5 × 3.5	27	49	34	10.7	20	20
NMR 15MN EE	16	8.5	15	9.5	40	6 × 3.5 × 4.5	32	44.6	27	12.8	20	25
NMR 15ML EE	16	8.5	15	9.5	40	6 × 3.5 × 4.5	32	61.6	44	12.8	25	25



Model	FABRICATE DIMENSION		RAIL DIMENSIONS (mm)				BLOCK DIMENSIONS (mm)					
	Height H	Width W ₂	W ₁	H ₁	P	D × d × g ₁	Width W	Length L	L ₁	h ₂	P ₁	P ₂
NMR 5MN EZ	6	3.5	5	3.5	15	3.5 × 2.4 × 1	12	16.6	10	4.9	—	8
NMR 5ML EZ	6	3.5	5	3.5	15	3.5 × 2.4 × 1	12	20.2	13.5	4.9	7	—
NMR 9MN EZ	10	5.5	9	5.5	20	6 × 3.5 × 3.5	20	31.6	20.5	8.3	10	15
NMR 9ML EZ	10	5.5	9	5.5	20	6 × 3.5 × 3.5	20	41.9	30.8	8.3	16	15
NMR 12MN EZ	13	7.5	12	7.5	25	6 × 3.5 × 3.5	27	36.8	22	10.7	15	20
NMR 12ML EZ	13	7.5	12	7.5	25	6 × 3.5 × 3.5	27	49	34	10.7	20	20
NMR 15MN EZ	16	8.5	15	9.5	40	6 × 3.5 × 4.5	32	44.6	27	12.8	20	25
NMR 15ML EZ	16	8.5	15	9.5	40	6 × 3.5 × 4.5	32	61.6	44	12.8	25	25

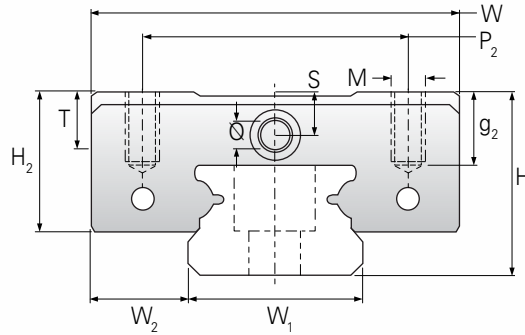

Load capacities are calculated according to ISO 14728. To compare the rating life definition and the load capacities: $C_{50} = 1.26 \times C_{100}$

LINEAR GUIDANCE

MINIATURE LINEAR BALL RAILS



BLOCK DIMENSIONS (mm)				BASIC LOAD RATINGS (N)		STATIC MOMENT RATINGS (Nm)			WEIGHT	
$M \times g_2$	\emptyset	S	T	Dynamic	Static				Block	Rail
				C_{100}	C_0	g	g/m			
M2 × 1.5	0.7	1.3	2	335	550	1	1	1.7	3.5	116
M2.6 × 2.0	0.7	1.3	2	470	900	2.1	2.1	2.4	4	116
M3 × 3.0	1.3	2.2	3.3	1,570	2,495	6.4	6.4	11.7	18	301
M3 × 3.0	1.3	2.2	3.3	2,135	3,880	12.4	12.4	18.2	28	301
M3 × 3.5	1.3	3.2	4.3	2,308	3,465	12.9	12.9	21.5	34	602
M3 × 3.5	1.3	3.2	4.3	3,240	5,630	30.2	30.2	34.9	51	602
M3 × 5.5	1.8	3.3	4.3	3,810	5,590	27	27	43.6	61	930
M3 × 5.5	1.8	3.3	4.3	5,350	9,080	63.3	63.3	70	90	930

BLOCK DIMENSIONS (mm)				BASIC LOAD RATINGS (N)		STATIC MOMENT RATINGS (Nm)			WEIGHT	
$M \times g_2$	\emptyset	S	T	Dynamic	Static				Block	Rail
				C_{100}	C_0	g	g/m			
M2 × 1.5	0.7	1.3	2	335	550	1	1	1.7	3.5	116
M2.6 × 2.0	0.7	1.3	2	470	900	2.1	2.1	2.4	4	116
M3 × 3.0	1.3	2.2	3.3	1,570	2,495	6.4	6.4	11.7	18	301
M3 × 3.0	1.3	2.2	3.3	2,135	3,880	12.4	12.4	18.2	28	301
M3 × 3.5	1.3	3.2	4.3	2,308	3,465	12.9	12.9	21.5	34	602
M3 × 3.5	1.3	3.2	4.3	3,240	5,630	30.2	30.2	34.9	51	602
M3 × 5.5	1.8	3.3	4.3	3,810	5,590	27	27	43.6	61	930
M3 × 5.5	1.8	3.3	4.3	5,350	9,080	63.3	63.3	70	90	930

STANDARD NMR-M

EU - END SEAL, REINFORCEMENT PLATE, STAINLESS BOTTOM SEAL
UZ - END SEAL, REINFORCEMENT PLATE, STAINLESS BOTTOM SEAL, LUBRICATION STORAGE
MN - STANDARD BLOCK LENGTH
ML - LONG BLOCK LENGTH
FOUR TAPPED HOLES

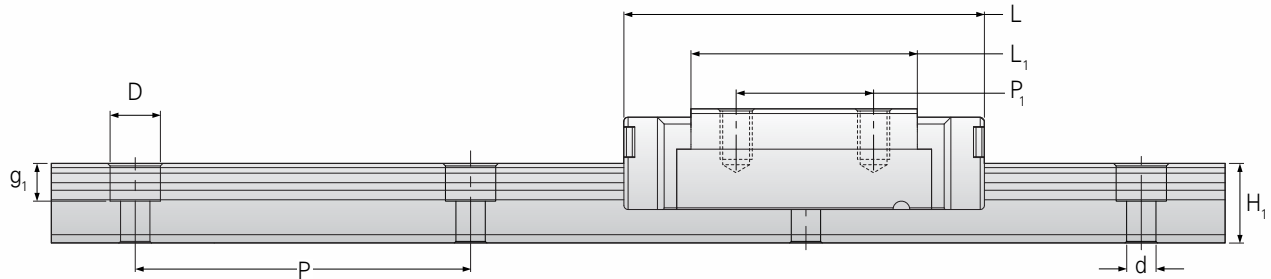

Model	FABRICATE DIMENSION		RAIL DIMENSIONS (mm)				BLOCK DIMENSIONS (mm)					
	Height H	Width W ₂	W ₁	H ₁	P	D × d × g ₁	Width W	Length L	L ₁	h ₂	P ₁	P ₂
NMR 9MN EU	10	5.5	9	5.5	20	6 × 3.5 × 3.5	20	31.6	20.5	8.6	10	15
NMR 9ML EU	10	5.5	9	5.5	20	6 × 3.5 × 3.5	20	41.9	30.8	8.6	16	15
NMR 12MN EU	13	7.5	12	7.5	25	6 × 3.5 × 3.5	27	36.8	22	11	15	20
NMR 12ML EU	13	7.5	12	7.5	25	6 × 3.5 × 3.5	27	49	34	11	20	20
NMR 15MN EU	16	8.5	15	9.5	40	6 × 3.5 × 4.5	32	44.6	27	13.1	20	25
NMR 15ML EU	16	8.5	15	9.5	40	6 × 3.5 × 4.5	32	61.6	44	13.1	25	25



Model	FABRICATE DIMENSION		RAIL DIMENSIONS (mm)				BLOCK DIMENSIONS (mm)					
	Height H	Width W ₂	W ₁	H ₁	P	D × d × g ₁	Width W	Length L	L ₁	h ₂	P ₁	P ₂
NMR 9MN UZ	10	5.5	9	5.5	20	6 × 3.5 × 3.5	20	31.6	20.5	8.3	10	15
NMR 9ML UZ	10	5.5	9	5.5	20	6 × 3.5 × 3.5	20	41.9	30.8	8.3	16	15
NMR 12MN UZ	13	7.5	12	7.5	25	6 × 3.5 × 3.5	27	36.8	22	10.7	15	20
NMR 12ML UZ	13	7.5	12	7.5	25	6 × 3.5 × 3.5	27	49	34	10.7	20	20
NMR 15MN UZ	16	8.5	15	9.5	40	6 × 3.5 × 4.5	32	44.6	27	12.8	20	25
NMR 15ML UZ	16	8.5	15	9.5	40	6 × 3.5 × 4.5	32	61.6	44	12.8	25	25

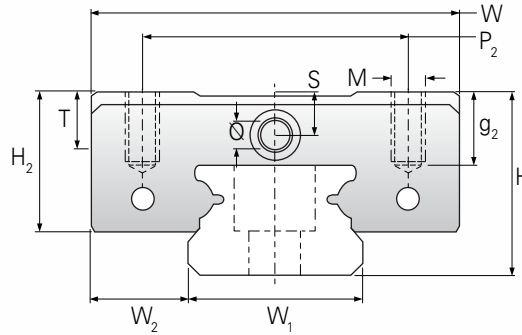

Load capacities are calculated according to ISO 14728. To compare the rating life definition and the load capacities: $C_{50} = 1.26 \times C_{100}$

LINEAR GUIDANCE

MINIATURE LINEAR BALL RAILS



BLOCK DIMENSIONS (mm)				BASIC LOAD RATINGS (N)		STATIC MOMENT RATINGS (Nm)			WEIGHT	
$M \times g_2$	\emptyset	S	T	Dynamic	Static				Block	Rail
				C_{100}	C_0				g	g/m
M3 × 3.0	1.3	2.2	3.3	1,570	2,495	6.4	6.4	11.7	18	301
M3 × 3.0	1.3	2.2	3.3	2,135	3,880	12.4	12.4	18.2	28	301
M3 × 3.5	1.3	3.2	4.3	2,308	3,465	12.9	12.9	21.5	34	602
M3 × 3.5	1.3	3.2	4.3	3,240	5,630	30.2	30.2	34.9	51	602
M3 × 5.5	1.8	3.3	4.3	3,810	5,590	27	27	43.6	61	930
M3 × 5.5	1.8	3.3	4.3	5,350	9,080	63.3	63.3	70	90	930

BLOCK DIMENSIONS (mm)				BASIC LOAD RATINGS (N)		STATIC MOMENT RATINGS (Nm)			WEIGHT	
$M \times g_2$	\emptyset	S	T	Dynamic	Static				Block	Rail
				C_{100}	C_0				g	g/m
M3 × 3.0	1.3	2.2	3.3	1,570	2,495	6.4	6.4	11.7	18	301
M3 × 3.0	1.3	2.2	3.3	2,135	3,880	12.4	12.4	18.2	28	301
M3 × 3.5	1.3	3.2	4.3	2,308	3,465	12.9	12.9	21.5	34	602
M3 × 3.5	1.3	3.2	4.3	3,240	5,630	30.2	30.2	34.9	51	602
M3 × 5.5	1.8	3.3	4.3	3,810	5,590	27	27	43.6	61	930
M3 × 5.5	1.8	3.3	4.3	5,350	9,080	63.3	63.3	70	90	930

WIDE NMR-W **SU - END SEAL, BOTTOM SEAL**
WN - STANDARD BLOCK LENGTH
WL - LONG BLOCK LENGTH
FOUR TAPPED HOLES

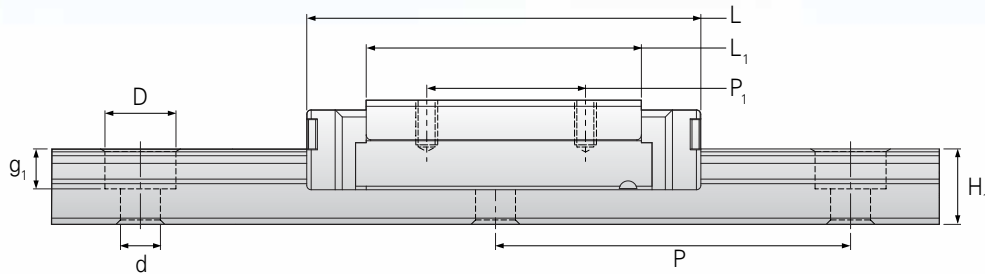

Model	DIMENSION		RAIL DIMENSIONS (mm)					BLOCK DIMENSIONS (mm)					
	Height	Width	W ₁	H ₁	P	P ₃	D × d × g ₁	Width	Length				
	H	W ₂	W ₁	H ₁	P	P ₃	D × d × g ₁	W	L	L ₁	h ₂	P ₁	P ₂
NMR 2WL SU*	4	3	4	3	10	—	2.8 × 1.8 × 1	10	17	11.9	3.1	6.5	—
NMR 3WN SU*	4.5	3	6	2.7	15	—	4 × 2.4 × 1.5	12	15	10	3.6	4.5	—
NMR 3WL SU*	4.5	3	6	2.7	15	—	4 × 2.4 × 1.5	12	20.1	15.1	3.6	8	—
NMR 5WN SU*	6.5	3.5	10	4	20	—	5.5 × 3 × 1.6	17	21.1	15.1	5.1	6.5	13
NMR 5WL SU*	6.5	3.5	10	4	20	—	5.5 × 3 × 1.6	17	27.2	21.2	5.1	11	13
NMR 7WN SU	9	5.5	14	5.2	30	—	6 × 3.5 × 3.5	25	31.6	21.2	7	10	19
NMR 7WL SU	9	5.5	14	5.2	30	—	6 × 3.5 × 3.5	25	40.5	30.1	7	19	19
NMR 9WN SU	12	6	18	7.3	30	—	6 × 3.5 × 3.5	30	39.1	27.9	8.6	12	21
NMR 9WL SU	12	6	18	7.3	30	—	6 × 3.5 × 3.5	30	50.7	39.5	8.6	24	23
NMR 12WN SU	14	8	24	8.5	40	—	8 × 4.5 × 4.5	40	44.4	31	10.1	15	28
NMR 12WL SU	14	8	24	8.5	40	—	8 × 4.5 × 4.5	40	59.4	46	10.1	28	28
NMR 15WN SU	16	9	42	9.5	40	23	8 × 4.5 × 4.5	60	55.3	38.5	12	20	45
NMR 15WL SU	16	9	42	9.5	40	23	8 × 4.5 × 4.5	60	74.4	57.6	12	35	45

WIDE NMR-W **SU - END SEAL, BOTTOM SEAL**
WNC - STANDARD BLOCK LENGTH
WLC - LONG BLOCK LENGTH

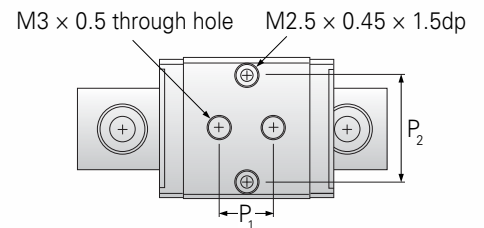

Model	DIMENSION		RAIL DIMENSIONS (mm)					BLOCK DIMENSIONS (mm)					
	Height	Width	W ₁	H ₁	P	P ₃	D × d × g ₁	Width	Length				
	H	W ₂	W ₁	H ₁	P	P ₃	D × d × g ₁	W	L	L ₁	h ₂	P ₁	P ₂
NMR 5WLC SU	6.5	3.5	10	4	20	—	5.5 × 3 × 1.6	17	27.2	21.2	5.1	11	13
NMR 5WNC SU	6.5	3.5	10	4	20	—	5.5 × 3 × 1.6	17	21.1	15.1	5.1	6.5	13

Load capacities are calculated according to ISO 14728. To compare the rating life definition and the load capacities: $C_{50} = 1.26 \times C_{100}$

NOTE: WNC and WLC are replacements for IKO and THK.

LINEAR GUIDANCE

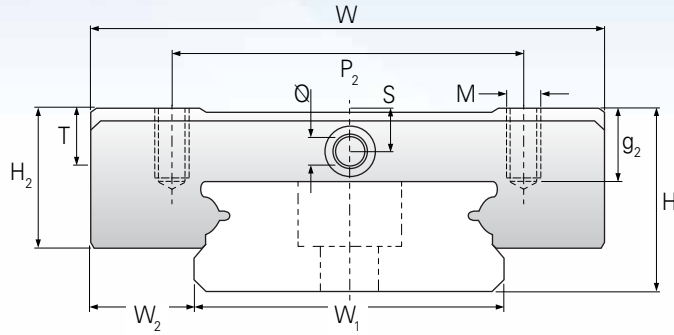

MINIATURE LINEAR BALL RAILS



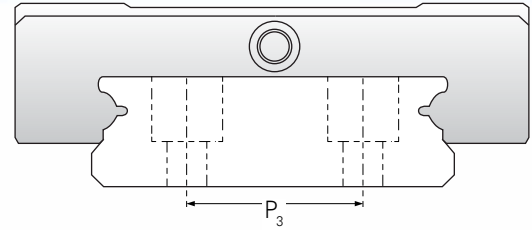

One Mounting Hole (NMR 3W–NMR 12W)



Two Mounting Holes (NMR 15W)

BLOCK DIMENSIONS (mm)				BASIC LOAD RATINGS (N)		STATIC MOMENT RATINGS (Nm)			WEIGHT	
$M \times g_2$	\varnothing	S	T	Dynamic	Static				Block	Rail
				C_{100}	C_0				g	g/m
M2 × 1.3	—	—	1.3	310	625	1.2	1.2	1.6	3.0	69
M2 × 1.4	0.3	0.8	1.8	280	530	0.9	0.9	1.6	3.4	105
M2 × 1.4	0.3	0.8	1.8	370	800	1.9	1.9	2.5	3.4	105
M2.5 × 1.5	0.9	1.2	2.3	475	900	2.2	2.2	4.6	6	280
M2.5 × 1.5	0.9	1.2	2.3	615	1,315	4.1	4.1	6.8	8	280
M3 × 3	1.1	1.9	3.2	1,180	2,095	7.3	7.3	15	19	516
M3 × 3	1.1	1.9	3.2	1,570	3,140	14.9	14.9	22.65	27	516
M3 × 3	1.3	2.6	4	2,030	3,605	13.7	13.7	33.2	37	940
M3 × 3	1.3	2.6	4	2,550	4,990	26.7	26.7	45.9	51	940
M3 × 3.5	1.3	2.8	4.5	3,065	5,200	26.3	26.3	63.7	65	1,472
M3 × 3.5	1.3	2.8	4.5	4,070	7,800	56.4	56.4	95.6	93	1,472
M4 × 4.5	1.8	3.3	4.5	5,065	8,385	45.7	45.7	171.7	137	2,818
M4 × 4.5	1.8	3.3	4.5	6,725	12,580	93.1	93.1	257.6	200	2,818

MINIATURE LINEAR BALL RAILS

BLOCK DIMENSIONS (mm)				BASIC LOAD RATINGS (N)		STATIC MOMENT RATINGS (Nm)			WEIGHT	
$M \times g_2$	\varnothing	S	T	Dynamic	Static				Block	Rail
				C_{100}	C_0				g	g/m
M3 / M2.5 × 1.5	0.9	1.2	2.3	615	1,315	4.1	4.1	6.8	8	280
M3 / M2.5 × 1.5	0.9	1.2	2.3	475	900	2.2	2.2	4.6	6	280

WIDE NMR-W **ZU - END SEAL, BOTTOM SEAL, LUBRICATION STORAGE**
WN - STANDARD BLOCK LENGTH
WL - LONG BLOCK LENGTH
FOUR TAPPED HOLES

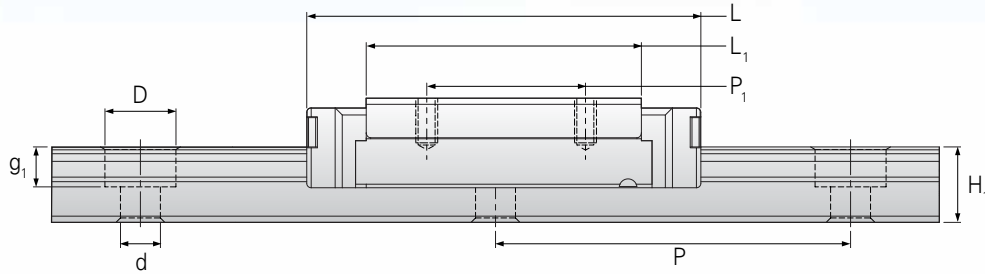

Model	DIMENSION		RAIL DIMENSIONS (mm)					BLOCK DIMENSIONS (mm)					
	Height H	Width W ₂	W ₁	H ₁	P	P ₃	D × d × g ₁	Width W	Length				
	H	W ₂	W ₁	H ₁	P	P ₃	D × d × g ₁	W	L	L ₁	h ₂	P ₁	P ₂
NMR 2WL ZU*	4	3	4	3	10	—	2.8 × 1.8 × 1	10	17	11.9	3.1	6.5	—
NMR 3WN ZU*	4.5	3	6	2.7	15	—	4 × 2.4 × 1.5	12	15	10	3.6	4.5	—
NMR 3WL ZU*	4.5	3	6	2.7	15	—	4 × 2.4 × 1.5	12	20.1	15.1	3.6	8	—
NMR 5WN ZU*	6.5	3.5	10	4	20	—	5.5 × 3 × 1.6	17	21.1	15.1	5.1	6.5	13
NMR 5WL ZU*	6.5	3.5	10	4	20	—	5.5 × 3 × 1.6	17	27.2	21.2	5.1	11	13
NMR 7WN ZU	9	5.5	14	5.2	30	—	6 × 3.5 × 3.5	25	31.6	21.2	7	10	19
NMR 7WL ZU	9	5.5	14	5.2	30	—	6 × 3.5 × 3.5	25	40.5	30.1	7	19	19
NMR 9WN ZU	12	6	18	7.3	30	—	6 × 3.5 × 3.5	30	39.1	27.9	8.6	12	21
NMR 9WL ZU	12	6	18	7.3	30	—	6 × 3.5 × 3.5	30	50.7	39.5	8.6	24	23
NMR 12WN ZU	14	8	24	8.5	40	—	8 × 4.5 × 4.5	40	44.4	31	10.1	15	28
NMR 12WL ZU	14	8	24	8.5	40	—	8 × 4.5 × 4.5	40	59.4	46	10.1	28	28
NMR 15WN ZU	16	9	42	9.5	40	23	8 × 4.5 × 4.5	60	55.3	38.5	12	20	45
NMR 15WL ZU	16	9	42	9.5	40	23	8 × 4.5 × 4.5	60	74.4	57.6	12	35	45

WIDE NMR-W **ZU - END SEAL, BOTTOM SEAL, LUBRICATION STORAGE**
WNC - STANDARD BLOCK LENGTH
WLC - LONG BLOCK LENGTH

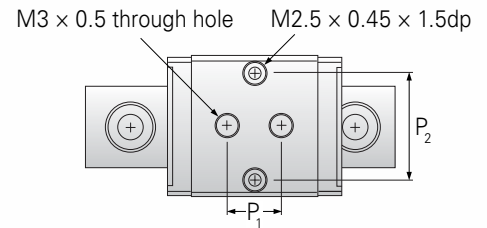

Model	DIMENSION		RAIL DIMENSIONS (mm)					BLOCK DIMENSIONS (mm)					
	Height H	Width W ₂	W ₁	H ₁	P	P ₃	D × d × g ₁	Width W	Length				
	H	W ₂	W ₁	H ₁	P	P ₃	D × d × g ₁	W	L	L ₁	h ₂	P ₁	P ₂
NMR 5WLC ZU	6.5	3.5	10	4	20	—	5.5 × 3 × 1.6	17	27.2	21.2	5.1	11	13
NMR 5WNC ZU	6.5	3.5	10	4	20	—	5.5 × 3 × 1.6	17	21.1	15.1	5.1	6.5	13

Load capacities are calculated according to ISO 14728. To compare the rating life definition and the load capacities: $C_{50} = 1.26 \times C_{100}$

NOTE: WNC and WLC are replacements for IKO and THK.

LINEAR GUIDANCE

MINIATURE LINEAR BALL RAILS

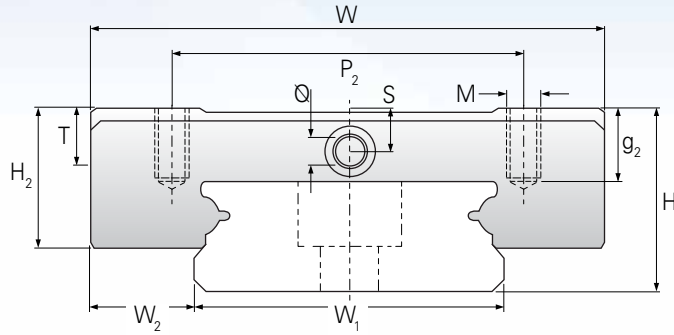

One Mounting Hole (NMR 3W–NMR 12W)

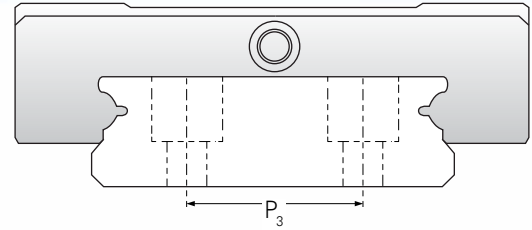

Two Mounting Holes (NMR 15W)

BLOCK DIMENSIONS (mm)				BASIC LOAD RATINGS (N)		STATIC MOMENT RATINGS (Nm)			WEIGHT	
$M \times g_2$	\varnothing	S	T	Dynamic C_{100}	Static C_0	M_A	M_B	M_C	Block g	Rail g/m
M2 × 1.3	—	—	1.3	310	625	1.2	1.2	1.6	3.0	69
M2 × 1.4	0.3	0.8	1.8	280	530	0.9	0.9	1.6	3.4	105
M2 × 1.4	0.3	0.8	1.8	370	800	1.9	1.9	2.5	3.4	105
M2.5 × 1.5	0.9	1.2	2.3	475	900	2.2	2.2	4.6	6	280
M2.5 × 1.5	0.9	1.2	2.3	615	1,315	4.1	4.1	6.8	8	280
M3 × 3	1.1	1.9	3.2	1,180	2,095	7.3	7.3	15	19	516
M3 × 3	1.1	1.9	3.2	1,570	3,140	14.9	14.9	22.65	27	516
M3 × 3	1.3	2.6	4	2,030	3,605	13.7	13.7	33.2	37	940
M3 × 3	1.3	2.6	4	2,550	4,990	26.7	26.7	45.9	51	940
M3 × 3.5	1.3	2.8	4.5	3,065	5,200	26.3	26.3	63.7	65	1,472
M3 × 3.5	1.3	2.8	4.5	4,070	7,800	56.4	56.4	95.6	93	1,472
M4 × 4.5	1.8	3.3	4.5	5,065	8,385	45.7	45.7	171.7	137	2,818
M4 × 4.5	1.8	3.3	4.5	6,725	12,580	93.1	93.1	257.6	200	2,818

BLOCK DIMENSIONS (mm)				BASIC LOAD RATINGS (N)		STATIC MOMENT RATINGS (Nm)			WEIGHT	
$M \times g_2$	\varnothing	S	T	Dynamic C_{100}	Static C_0	M_A	M_B	M_C	Block g	Rail g/m
M3 / M2.5 × 1.5	0.9	1.2	2.3	615	1,315	4.1	4.1	6.8	8	280
M3 / M2.5 × 1.5	0.9	1.2	2.3	475	900	2.2	2.2	4.6	6	280

MINIATURE LINEAR BALL RAILS

WIDE NMR-W SS - END SEAL
WN - STANDARD BLOCK LENGTH
WL - LONG BLOCK LENGTH
FOUR TAPPED HOLES

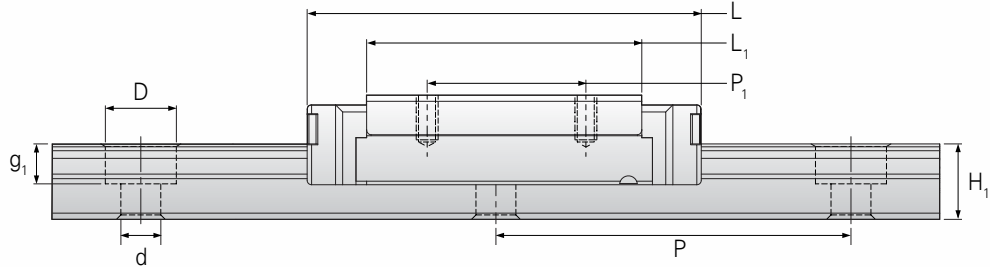

Model	DIMENSION		RAIL DIMENSIONS (mm)					BLOCK DIMENSIONS (mm)					
	Height H	Width W ₂	W ₁	H ₁	P	P ₃	D × d × g ₁	Width W	Length				
									L	L ₁	h ₂	P ₁	P ₂
NMR 2WL SS	4	3	4	3	10	—	2.8 × 1.8 × 1	10	17	11.9	3	6.5	—
NMR 3WN SS	4.5	3	6	2.7	15	—	4 × 2.4 × 1.5	12	15	10	3.5	4.5	—
NMR 3WL SS	4.5	3	6	2.7	15	—	4 × 2.4 × 1.5	12	20.1	15.1	3.5	8	—
NMR 5WN SS	6.5	3.5	10	4	20	—	5.5 × 3 × 1.6	17	21.1	15.1	5	6.5	13
NMR 5WL SS	6.5	3.5	10	4	20	—	5.5 × 3 × 1.6	17	27.2	21.2	5	11	13
NMR 7WN SS	9	5.5	14	5.2	30	—	6 × 3.5 × 3.5	25	31.6	21.2	7	10	19
NMR 7WL SS	9	5.5	14	5.2	30	—	6 × 3.5 × 3.5	25	40.5	30.1	7	19	19
NMR 9WN SS	12	6	18	7.3	30	—	6 × 3.5 × 3.5	30	39.1	27.9	8.6	12	21
NMR 9WL SS	12	6	18	7.3	30	—	6 × 3.5 × 3.5	30	50.7	39.5	8.6	24	23
NMR 12WN SS	14	8	24	8.5	40	—	8 × 4.5 × 4.5	40	44.4	31	10.1	15	28
NMR 12WL SS	14	8	24	8.5	40	—	8 × 4.5 × 4.5	40	59.4	46	10.1	28	28
NMR 15WN SS	16	9	42	9.5	40	23	8 × 4.5 × 4.5	60	55.3	38.5	12	20	45
NMR 15WL SS	16	9	42	9.5	40	23	8 × 4.5 × 4.5	60	74.4	57.6	12	35	45

WIDE NMR-W SS - END SEAL
WNC - STANDARD BLOCK LENGTH
WLC - LONG BLOCK LENGTH

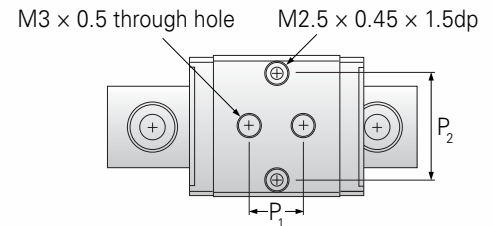

Model	DIMENSION		RAIL DIMENSIONS (mm)					BLOCK DIMENSIONS (mm)					
	Height H	Width W ₂	W ₁	H ₁	P	P ₃	D × d × g ₁	Width W	Length				
									L	L ₁	h ₂	P ₁	P ₂
NMR 5WLC SS	6.5	3.5	10	4	20	—	5.5 × 3 × 1.6	17	27.2	21.2	5	11	13
NMR 5WNC SS	6.5	3.5	10	4	20	—	5.5 × 3 × 1.6	17	21.1	15.1	5	6.5	13

Load capacities are calculated according to ISO 14728. To compare the rating life definition and the load capacities: $C_{50} = 1.26 \times C_{100}$

NOTE: WNC and WLC are replacements for IKO and THK.

LINEAR GUIDANCE

MINIATURE LINEAR BALL RAILS

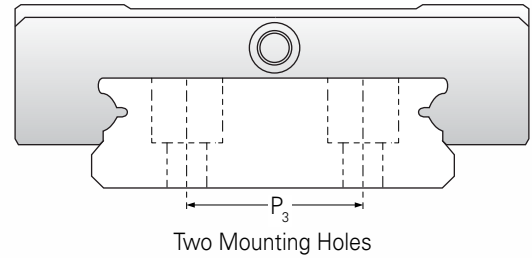
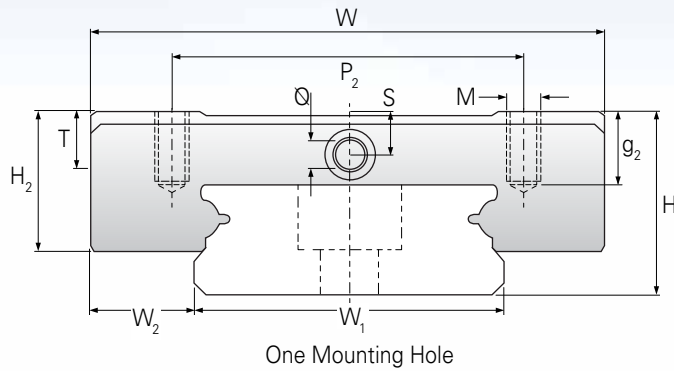

BLOCK DIMENSIONS (mm)				BASIC LOAD RATINGS (N)		STATIC MOMENT RATINGS (Nm)			WEIGHT	
M × g ₂	Ø	S	T	Dynamic	Static				Block	Rail
				C ₁₀₀	C ₀				g	g/m
M2 × 1.3	—	—	1.3	310	625	1.2	1.2	1.6	3.0	69
M2 × 1.4	0.3	0.8	1.8	280	530	0.9	0.9	1.6	3.4	105
M2 × 1.4	0.3	0.8	1.8	370	800	1.9	1.9	2.5	3.4	105
M2.5 × 1.5	0.9	1.2	2.3	475	900	2.2	2.2	4.6	6	280
M2.5 × 1.5	0.9	1.2	2.3	615	1,315	4.1	4.1	6.8	8	280
M3 × 3	1.1	1.9	3.2	1,180	2,095	7.3	7.3	15	19	516
M3 × 3	1.1	1.9	3.2	1,570	3,140	14.9	14.9	22.65	27	516
M3 × 3	1.3	2.6	4	2,030	3,605	13.7	13.7	33.2	37	940
M3 × 3	1.3	2.6	4	2,550	4,990	26.7	26.7	45.9	51	940
M3 × 3.5	1.3	3.1	4.5	3,065	5,200	26.3	26.3	63.7	65	1,472
M3 × 3.5	1.3	3.1	4.5	4,070	7,800	56.4	56.4	95.6	93	1,472
M4 × 4.5	1.8	3.3	4.5	5,065	8,385	45.7	45.7	171.7	137	2,818
M4 × 4.5	1.8	3.3	4.5	6,725	12,580	93.1	93.1	257.6	200	2,818

BLOCK DIMENSIONS (mm)				BASIC LOAD RATINGS (N)		STATIC MOMENT RATINGS (Nm)			WEIGHT	
M × g ₂	Ø	S	T	Dynamic	Static				Block	Rail
				C ₁₀₀	C ₀				g	g/m
M3 / M2.5 × 1.5	0.9	1.2	2.3	615	1,315	4.1	4.1	6.8	8	280
M3 / M2.5 × 1.5	0.9	1.2	2.3	475	900	2.2	2.2	4.6	6	280

WIDE NMR-W **ZZ - END SEAL, LUBRICATION STORAGE**
WN - STANDARD BLOCK LENGTH
WL - LONG BLOCK LENGTH
FOUR TAPPED HOLES

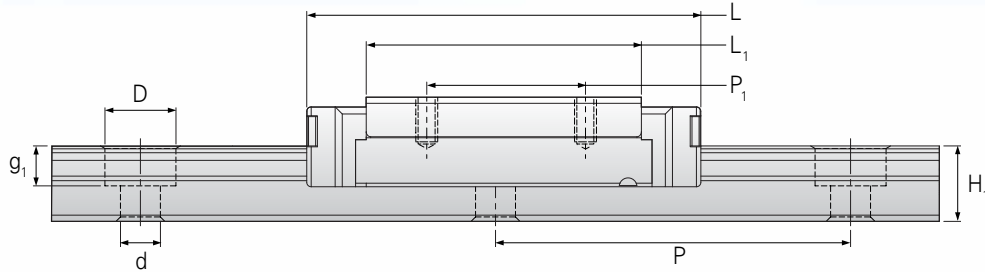

Model	DIMENSION		RAIL DIMENSIONS (mm)					BLOCK DIMENSIONS (mm)					
	Height H	Width W ₂	W ₁	H ₁	P	P ₃	D × d × g ₁	Width W	Length L	L ₁	h ₂	P ₁	P ₂
NMR 2WL ZZ*	4	3	4	3	10	—	2.8 × 1.8 × 1	10	17	11.9	3	6.5	—
NMR 3WN ZZ*	4.5	3	6	2.7	15	—	4 × 2.4 × 1.5	12	15	10	3.5	4.5	—
NMR 3WL ZZ*	4.5	3	6	2.7	15	—	4 × 2.4 × 1.5	12	20.1	15.1	3.5	8	—
NMR 5WN ZZ	6.5	3.5	10	4	20	—	5.5 × 3 × 1.6	17	21.1	15.1	5	6.5	13
NMR 5WL ZZ	6.5	3.5	10	4	20	—	5.5 × 3 × 1.6	17	27.2	21.2	5	11	13
NMR 7WN ZZ	9	5.5	14	5.2	30	—	6 × 3.5 × 3.5	25	31.6	21.2	7	10	19
NMR 7WL ZZ	9	5.5	14	5.2	30	—	6 × 3.5 × 3.5	25	40.5	30.1	7	19	19
NMR 9WN ZZ	12	6	18	7.3	30	—	6 × 3.5 × 3.5	30	39.1	27.9	8.6	12	21
NMR 9WL ZZ	12	6	18	7.3	30	—	6 × 3.5 × 3.5	30	50.7	39.5	8.6	24	23
NMR 12WN ZZ	14	8	24	8.5	40	—	8 × 4.5 × 4.5	40	44.4	31	10.1	15	28
NMR 12WL ZZ	14	8	24	8.5	40	—	8 × 4.5 × 4.5	40	59.4	46	10.1	28	28
NMR 15WN ZZ	16	9	42	9.5	40	23	8 × 4.5 × 4.5	60	55.3	38.5	12	20	45
NMR 15WL ZZ	16	9	42	9.5	40	23	8 × 4.5 × 4.5	60	74.4	57.6	12	35	45

*Check availability

WIDE NMR-W **ZZ - END SEAL, LUBRICATION STORAGE**
WNC - STANDARD BLOCK LENGTH
WLC - LONG BLOCK LENGTH

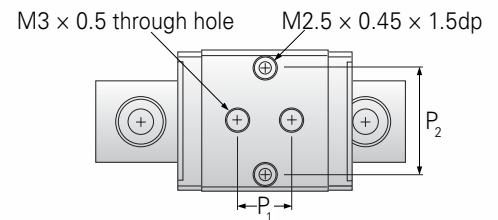





Model	DIMENSION		RAIL DIMENSIONS (mm)					BLOCK DIMENSIONS (mm)					
	Height H	Width W ₂	W ₁	H ₁	P	P ₃	D × d × g ₁	Width W	Length L	L ₁	h ₂	P ₁	P ₂
NMR 5WLC ZZ	6.5	3.5	10	4	20	—	5.5 × 3 × 1.6	17	27.2	21.2	5	11	13
NMR 5WNC ZZ	6.5	3.5	10	4	20	—	5.5 × 3 × 1.6	17	21.1	15.1	5	6.5	13

Load capacities are calculated according to ISO 14728. To compare the rating life definition and the load capacities: $C_{50} = 1.26 \times C_{100}$

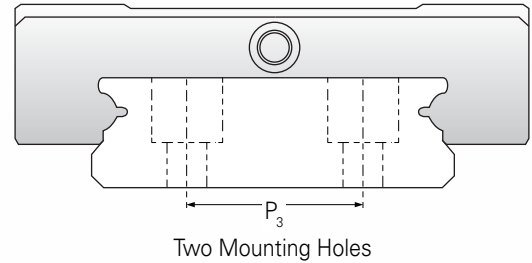
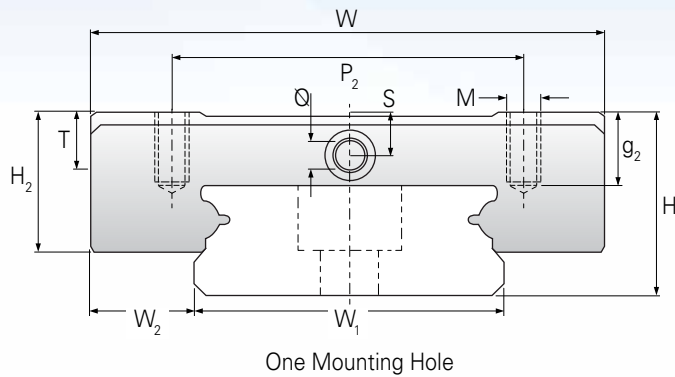

NOTE: WNC and WLC are replacements for IKO and THK.

LINEAR GUIDANCE MINIATURE LINEAR BALL RAILS



BLOCK DIMENSIONS (mm)				BASIC LOAD RATINGS (N)		STATIC MOMENT RATINGS (Nm)			WEIGHT	
M × g ₂	Ø	S	T	Dynamic	Static				Block	Rail
				C ₁₀₀	C ₀				g	g/m
M2 × 1.3	—	—	1.3	310	625	1.2	1.2	1.6	3.0	69
M2 × 1.4	0.3	0.8	1.8	280	530	0.9	0.9	1.6	3.4	105
M2 × 1.4	0.3	0.8	1.8	370	800	1.9	1.9	2.5	3.4	105
M2.5 × 1.5	0.9	1.2	2.3	475	900	2.2	2.2	4.6	6	280
M2.5 × 1.5	0.9	1.2	2.3	615	1,315	4.1	4.1	6.8	8	280
M3 × 3	1.1	1.9	3.2	1,180	2,095	7.3	7.3	15	19	516
M3 × 3	1.1	1.9	3.2	1,570	3,140	14.9	14.9	22.65	27	516
M3 × 3	1.3	2.6	4	2,030	3,605	13.7	13.7	33.2	37	940
M3 × 3	1.3	2.6	4	2,550	4,990	26.7	26.7	45.9	51	940
M3 × 3.5	1.3	3.1	4.5	3,065	5,200	26.3	26.3	63.7	65	1,472
M3 × 3.5	1.3	3.1	4.5	4,070	7,800	56.4	56.4	95.6	93	1,472
M4 × 4.5	1.8	3.3	4.5	5,065	8,385	45.7	45.7	171.7	137	2,818
M4 × 4.5	1.8	3.3	4.5	6,725	12,580	93.1	93.1	257.6	200	2,818

MINIATURE LINEAR BALL RAILS

BLOCK DIMENSIONS (mm)				BASIC LOAD RATINGS (N)		STATIC MOMENT RATINGS (Nm)			WEIGHT	
M × g ₂	Ø	S	T	Dynamic	Static				Block	Rail
				C ₁₀₀	C ₀				g	g/m
M3 / M2.5 × 1.5	0.9	1.2	2.3	615	1,315	4.1	4.1	6.8	8	280
M3 / M2.5 × 1.5	0.9	1.2	2.3	475	900	2.2	2.2	4.6	6	280

WIDE NMR-W

SUE - END SEAL, BOTTOM SEAL, REINFORCEMENT PLATE

ZUE - END SEAL, BOTTOM SEAL, REINFORCEMENT PLATE, LUBRICATION STORAGE

MN - STANDARD BLOCK LENGTH

ML - LONG BLOCK LENGTH

FOUR TAPPED HOLES

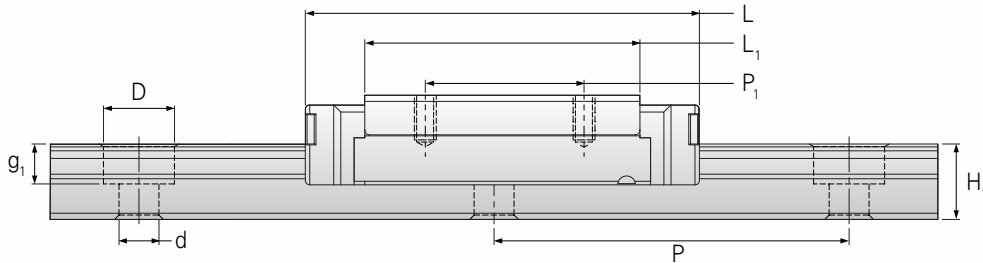

Model	DIMENSION		RAIL DIMENSIONS (mm)					BLOCK DIMENSIONS (mm)					
	Height H	Width W ₂	W ₁	H ₁	P	P ₃	D × d × g ₁	Width W	Length				
	H	W ₂	W ₁	H ₁	P	P ₃	D × d × g ₁	W	L	L ₁	h ₂	P ₁	P ₂
NMR 2WL EE	4	3	4	3	10	—	2.8 × 1.8 × 1	10	17.5	11.9	3.3	6.5	—
NMR 7WN EE	9	5.5	14	5.2	30	—	6 × 3.5 × 4.5	25	32.5	21.2	7.5	10	19
NMR 7WL EE	9	5.5	14	5.2	30	—	6 × 3.5 × 4.5	25	41.5	30.1	7.5	19	19
NMR 9WN EE	12	6	18	7.3	30	—	6 × 3.5 × 4.5	30	40.2	27.9	9.2	12	21
NMR 9WL EE	12	6	18	7.3	30	—	6 × 3.5 × 4.5	30	51.8	39.5	9.2	24	23
NMR 12WN EE	14	8	24	8.5	40	—	8 × 4.5 × 4.5	40	45.8	31	10.7	15	28
NMR 12WL EE	14	8	24	8.5	40	—	8 × 4.5 × 4.5	40	60.8	46	10.7	28	28
NMR 15WN EE	16	9	42	9.5	40	23	8 × 4.5 × 4.5	60	56.9	38.5	12.8	20	45
NMR 15WL EE	16	9	42	9.5	40	23	8 × 4.5 × 4.5	60	76	57.6	12.8	35	45

Model	DIMENSION		RAIL DIMENSIONS (mm)					BLOCK DIMENSIONS (mm)					
	Height H	Width W ₂	W ₁	H ₁	P	P ₃	D × d × g ₁	Width W	Length				
	H	W ₂	W ₁	H ₁	P	P ₃	D × d × g ₁	W	L	L ₁	h ₂	P ₁	P ₂
NMR 2WL EZ	4	3	4	3	10	—	2.8 × 1.8 × 1	10	17.5	11.9	3.3	6.5	—
NMR 7WN EZ	9	5.5	14	5.2	30	—	6 × 3.5 × 4.5	25	32.5	21.2	7.5	10	19
NMR 7WL EZ	9	5.5	14	5.2	30	—	6 × 3.5 × 4.5	25	41.5	30.1	7.5	19	19
NMR 9WN EZ	12	6	18	7.3	30	—	6 × 3.5 × 4.5	30	40.2	27.9	9.2	12	21
NMR 9WL EZ	12	6	18	7.3	30	—	6 × 3.5 × 4.5	30	51.8	39.5	9.2	24	23
NMR 12WN EZ	14	8	24	8.5	40	—	8 × 4.5 × 4.5	40	45.8	31	10.7	15	28
NMR 12WL EZ	14	8	24	8.5	40	—	8 × 4.5 × 4.5	40	60.8	46	10.7	28	28
NMR 15WN EZ	16	9	42	9.5	40	23	8 × 4.5 × 4.5	60	56.9	38.5	12.8	20	45
NMR 15WL EZ	16	9	42	9.5	40	23	8 × 4.5 × 4.5	60	76	57.6	12.8	35	45

Load capacities are calculated according to ISO 14728. To compare the rating life definition and the load capacities: $C_{50} = 1.26 \times C_{100}$

LINEAR GUIDANCE

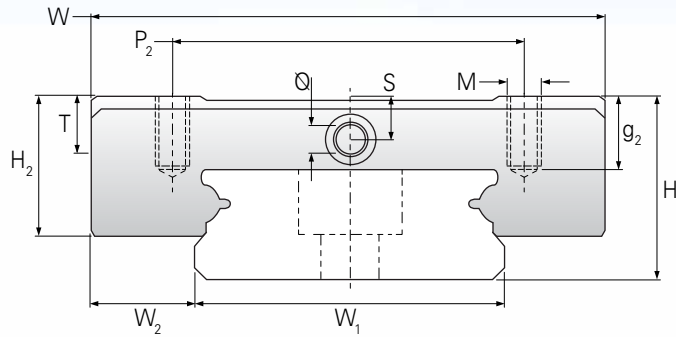

MINIATURE LINEAR BALL RAILS



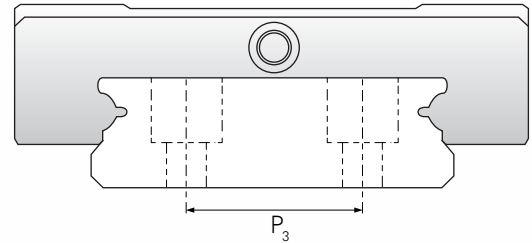

One Mounting Hole



Two Mounting Holes

BLOCK DIMENSIONS (mm)				BASIC LOAD RATINGS (N)		STATIC MOMENT RATINGS (Nm)			WEIGHT	
M × g ₂	Ø	S	T	Dynamic	Static				Block	Rail
				C ₁₀₀	C ₀	g	g/m			
M2 × 1.3	—	—	1.3	310	625	1.6	1.2	1.2	3.0	69
M3 × 3	1.1	1.9	3.2	1,180	2,095	15	7.3	7.3	19	516
M3 × 3	1.1	1.9	3.2	1,570	3,140	22.65	14.9	14.9	27	516
M3 × 3	1.3	2.6	4	2,030	3,605	33.2	13.7	13.7	37	940
M3 × 3	1.3	2.6	4	2,550	4,990	45.9	26.7	26.7	51	940
M3 × 3.5	1.3	3.1	4.5	3,065	5,200	63.7	26.3	26.3	68	1,472
M3 × 3.5	1.3	3.1	4.5	4,070	7,800	95.6	56.4	56.4	96	1,472
M3 × 4.5	1.8	3.3	4.5	5,065	8,385	171.7	45.7	45.7	140	2,818
M3 × 4.5	1.8	3.3	4.5	6,725	12,580	257.6	93.1	93.1	203	2,818

BLOCK DIMENSIONS (mm)				BASIC LOAD RATINGS (N)		STATIC MOMENT RATINGS (Nm)			WEIGHT	
M × g ₂	Ø	S	T	Dynamic	Static				Block	Rail
				C ₁₀₀	C ₀	g	g/m			
M2 × 1.3	—	—	1.3	310	625	1.6	1.2	1.2	3.0	69
M3 × 3	1.1	1.9	3.2	1,180	2,095	15	7.3	7.3	19	516
M3 × 3	1.1	1.9	3.2	1,570	3,140	22.65	14.9	14.9	27	516
M3 × 3	1.3	2.6	4	2,030	3,605	33.2	13.7	13.7	37	940
M3 × 3	1.3	2.6	4	2,550	4,990	45.9	26.7	26.7	51	940
M3 × 3.5	1.3	3.1	4.5	3,065	5,200	63.7	26.3	26.3	68	1,472
M3 × 3.5	1.3	3.1	4.5	4,070	7,800	95.6	56.4	56.4	96	1,472
M3 × 4.5	1.8	3.3	4.5	5,065	8,385	171.7	45.7	45.7	140	2,818
M3 × 4.5	1.8	3.3	4.5	6,725	12,580	257.6	93.1	93.1	203	2,818

MINIATURE LINEAR BALL RAILS

WIDE NMR-W

EE - END SEAL, REINFORCEMENT PLATE
EZ - END SEAL, REINFORCEMENT PLATE, LUBRICATION STORAGE
MN - STANDARD BLOCK LENGTH
ML - LONG BLOCK LENGTH
FOUR TAPPED HOLES

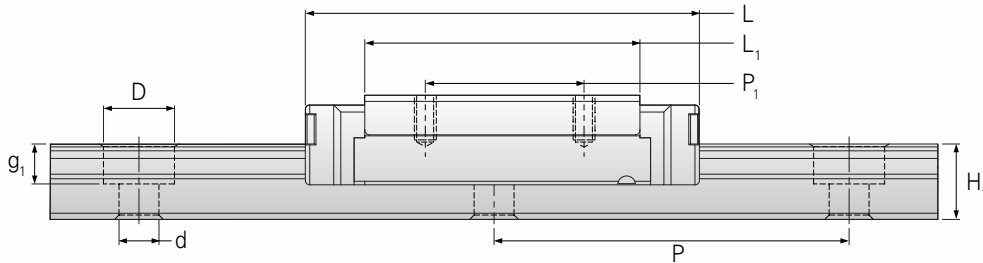

Model	DIMENSION		RAIL DIMENSIONS (mm)					BLOCK DIMENSIONS (mm)					
	Height	Width	W ₁	H ₁	P	P ₃	D × d × g ₁	Width	Length				
	H	W ₂	W ₁	H ₁	P	P ₃	D × d × g ₁	W	L	L ₁	h ₂	P ₁	P ₂
NMR 2WL EE	4	3	4	3	10	—	2.8 × 1.8 × 1	10	17.5	11.9	3.3	6.5	—
NMR 7WN EE	9	5.5	14	5.2	30	—	6 × 3.5 × 4.5	25	32.5	21.2	7.5	10	19
NMR 7WL EE	9	5.5	14	5.2	30	—	6 × 3.5 × 4.5	25	41.5	30.1	7.5	19	19
NMR 9WN EE	12	6	18	7.3	30	—	6 × 3.5 × 4.5	30	40.2	27.9	9.2	12	21
NMR 9WL EE	12	6	18	7.3	30	—	6 × 3.5 × 4.5	30	51.8	39.5	9.2	24	23
NMR 12WN EE	14	8	24	8.5	40	—	8 × 4.5 × 4.5	40	45.8	31	10.7	15	28
NMR 12WL EE	14	8	24	8.5	40	—	8 × 4.5 × 4.5	40	60.8	46	10.7	28	28
NMR 15WN EE	16	9	42	9.5	40	23	8 × 4.5 × 4.5	60	56.9	38.5	12.8	20	45
NMR 15WL EE	16	9	42	9.5	40	23	8 × 4.5 × 4.5	60	76	57.6	12.8	35	45

Model	DIMENSION		RAIL DIMENSIONS (mm)					BLOCK DIMENSIONS (mm)					
	Height	Width	W ₁	H ₁	P	P ₃	D × d × g ₁	Width	Length				
	H	W ₂	W ₁	H ₁	P	P ₃	D × d × g ₁	W	L	L ₁	h ₂	P ₁	P ₂
NMR 2WL EZ	4	3	4	3	10	—	2.8 × 1.8 × 1	10	17.5	11.9	3.3	6.5	—
NMR 7WN EZ	9	5.5	14	5.2	30	—	6 × 3.5 × 4.5	25	32.5	21.2	7.5	10	19
NMR 7WL EZ	9	5.5	14	5.2	30	—	6 × 3.5 × 4.5	25	41.5	30.1	7.5	19	19
NMR 9WN EZ	12	6	18	7.3	30	—	6 × 3.5 × 4.5	30	40.2	27.9	9.2	12	21
NMR 9WL EZ	12	6	18	7.3	30	—	6 × 3.5 × 4.5	30	51.8	39.5	9.2	24	23
NMR 12WN EZ	14	8	24	8.5	40	—	8 × 4.5 × 4.5	40	45.8	31	10.7	15	28
NMR 12WL EZ	14	8	24	8.5	40	—	8 × 4.5 × 4.5	40	60.8	46	10.7	28	28
NMR 15WN EZ	16	9	42	9.5	40	23	8 × 4.5 × 4.5	60	56.9	38.5	12.8	20	45
NMR 15WL EZ	16	9	42	9.5	40	23	8 × 4.5 × 4.5	60	76	57.6	12.8	35	45

Load capacities are calculated according to ISO 14728. To compare the rating life definition and the load capacities: $C_{50} = 1.26 \times C_{100}$

LINEAR GUIDANCE

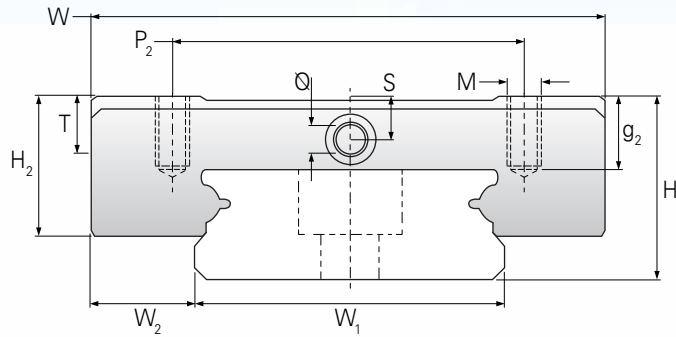

MINIATURE LINEAR BALL RAILS



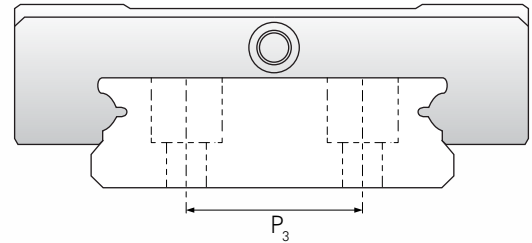

One Mounting Hole



Two Mounting Holes

BLOCK DIMENSIONS (mm)				BASIC LOAD RATINGS (N)		STATIC MOMENT RATINGS (Nm)			WEIGHT	
M × g ₂	Ø	S	T	Dynamic	Static				Block	Rail
				C ₁₀₀	C ₀	g	g/m			
M2 × 1.3	—	—	1.3	310	625	1.6	1.2	1.2	3.0	69
M3 × 3	1.1	1.9	3.2	1,180	2,095	15	7.3	7.3	19	516
M3 × 3	1.1	1.9	3.2	1,570	3,140	22.65	14.9	14.9	27	516
M3 × 3	1.3	2.6	4	2,030	3,605	33.2	13.7	13.7	37	940
M3 × 3	1.3	2.6	4	2,550	4,990	45.9	26.7	26.7	51	940
M3 × 3.5	1.3	3.1	4.5	3,065	5,200	63.7	26.3	26.3	68	1,472
M3 × 3.5	1.3	3.1	4.5	4,070	7,800	95.6	56.4	56.4	96	1,472
M3 × 4.5	1.8	3.3	4.5	5,065	8,385	171.7	45.7	45.7	140	2,818
M3 × 4.5	1.8	3.3	4.5	6,725	12,580	257.6	93.1	93.1	203	2,818

BLOCK DIMENSIONS (mm)				BASIC LOAD RATINGS (N)		STATIC MOMENT RATINGS (Nm)			WEIGHT	
M × g ₂	Ø	S	T	Dynamic	Static				Block	Rail
				C ₁₀₀	C ₀	g	g/m			
M2 × 1.3	—	—	1.3	310	625	1.6	1.2	1.2	3.0	69
M3 × 3	1.1	1.9	3.2	1,180	2,095	15	7.3	7.3	19	516
M3 × 3	1.1	1.9	3.2	1,570	3,140	22.65	14.9	14.9	27	516
M3 × 3	1.3	2.6	4	2,030	3,605	33.2	13.7	13.7	37	940
M3 × 3	1.3	2.6	4	2,550	4,990	45.9	26.7	26.7	51	940
M3 × 3.5	1.3	3.1	4.5	3,065	5,200	63.7	26.3	26.3	68	1,472
M3 × 3.5	1.3	3.1	4.5	4,070	7,800	95.6	56.4	56.4	96	1,472
M3 × 4.5	1.8	3.3	4.5	5,065	8,385	171.7	45.7	45.7	140	2,818
M3 × 4.5	1.8	3.3	4.5	6,725	12,580	257.6	93.1	93.1	203	2,818

MINIATURE LINEAR BALL RAILS

WIDE NMR-W **EU - END SEAL, REINFORCEMENT PLATE, STAINLESS BOTTOM SEAL**
UZ - END SEAL, REINFORCEMENT PLATE, STAINLESS BOTTOM SEAL,
LUBRICATION STORAGE
MN - STANDARD BLOCK LENGTH
ML - LONG BLOCK LENGTH
FOUR TAPPED HOLES

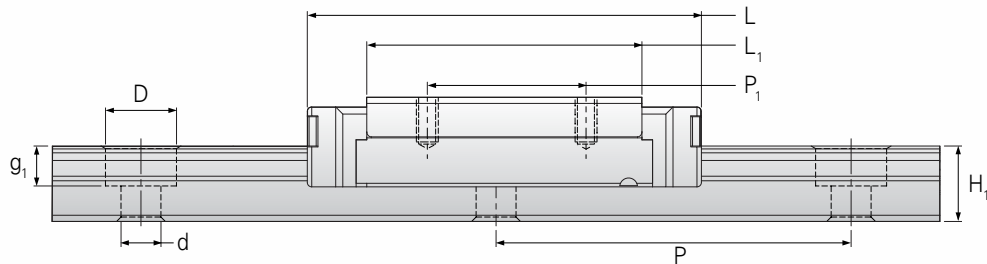

Model	DIMENSION		RAIL DIMENSIONS (mm)					BLOCK DIMENSIONS (mm)					
	Height H	Width W ₂	W ₁	H ₁	P	P ₃	D × d × g ₁	Width W	Length				
									L	L ₁	h ₂	P ₁	P ₂
NMR 9WN EU	12	6	18	7.3	30	—	6 × 3.5 × 4.5	30	40.2	27.9	9.2	12	21
NMR 9WL EU	12	6	18	7.3	30	—	6 × 3.5 × 4.5	30	51.8	39.5	9.2	24	23
NMR 12WN EU	14	8	24	8.5	40	—	8 × 4.5 × 4.5	40	45.8	31	10.7	15	28
NMR 12WL EU	14	8	24	8.5	40	—	8 × 4.5 × 4.5	40	60.8	46	10.7	28	28
NMR 15WN EU	16	9	42	9.5	40	23	8 × 4.5 × 4.5	60	56.9	38.5	12.8	20	45
NMR 15WL EU	16	9	42	9.5	40	23	8 × 4.5 × 4.5	60	76	57.6	12.8	35	45

Model	DIMENSION		RAIL DIMENSIONS (mm)					BLOCK DIMENSIONS (mm)					
	Height H	Width W ₂	W ₁	H ₁	P	P ₃	D × d × g ₁	Width W	Length				
									L	L ₁	h ₂	P ₁	P ₂
NMR 9WN UZ	12	6	18	7.3	30	—	6 × 3.5 × 4.5	30	40.2	27.9	9.2	12	21
NMR 9WL UZ	12	6	18	7.3	30	—	6 × 3.5 × 4.5	30	51.8	39.5	9.2	24	23
NMR 12WN UZ	14	8	24	8.5	40	—	8 × 4.5 × 4.5	40	45.8	31	10.7	15	28
NMR 12WL UZ	14	8	24	8.5	40	—	8 × 4.5 × 4.5	40	60.8	46	10.7	28	28
NMR 15WN UZ	16	9	42	9.5	40	23	8 × 4.5 × 4.5	60	56.9	38.5	12.8	20	45
NMR 15WL UZ	16	9	42	9.5	40	23	8 × 4.5 × 4.5	60	76	57.6	12.8	35	45

Load capacities are calculated according to ISO 14728. To compare the rating life definition and the load capacities: $C_{50} = 1.26 \times C_{100}$

LINEAR GUIDANCE

MINIATURE LINEAR BALL RAILS

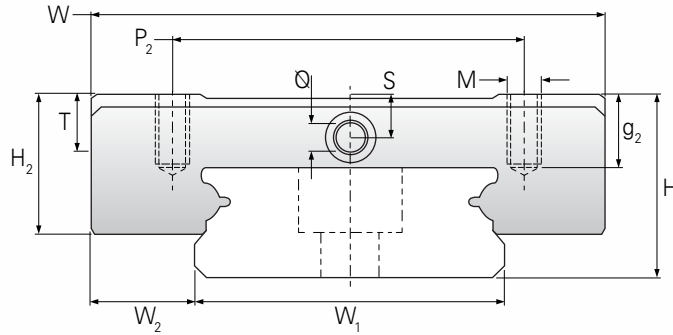

One Mounting Hole

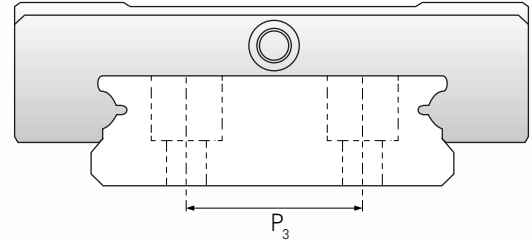

Two Mounting Holes

BLOCK DIMENSIONS (mm)				BASIC LOAD RATINGS (N)		STATIC MOMENT RATINGS (Nm)			WEIGHT	
$M \times g_2$	\varnothing	S	T	Dynamic	Static	M_A	M_B	M_C	Block	Rail
				C_{100}	C_0				g	g/m
M3 × 3	1.3	2.6	4	2,030	3,605	33.2	13.7	13.7	37	940
M3 × 3	1.3	2.6	4	2,550	4,990	45.9	26.7	26.7	51	940
M3 × 3.5	1.3	3.1	4.5	3,065	5,200	63.7	26.3	26.3	68	1,472
M3 × 3.5	1.3	3.1	4.5	4,070	7,800	95.6	56.4	56.4	96	1,472
M3 × 4.5	1.8	3.3	4.5	5,065	8,385	171.7	45.7	45.7	140	2,818
M3 × 4.5	1.8	3.3	4.5	6,725	12,580	257.6	93.1	93.1	203	2,818

BLOCK DIMENSIONS (mm)				BASIC LOAD RATINGS (N)		STATIC MOMENT RATINGS (Nm)			WEIGHT	
$M \times g_2$	\varnothing	S	T	Dynamic	Static	M_A	M_B	M_C	Block	Rail
				C_{100}	C_0				g	g/m
M3 × 3	1.3	2.6	4	2,030	3,605	33.2	13.7	13.7	37	940
M3 × 3	1.3	2.6	4	2,550	4,990	45.9	26.7	26.7	51	940
M3 × 3.5	1.3	3.1	4.5	3,065	5,200	63.7	26.3	26.3	68	1,472
M3 × 3.5	1.3	3.1	4.5	4,070	7,800	95.6	56.4	56.4	96	1,472
M3 × 4.5	1.8	3.3	4.5	5,065	8,385	171.7	45.7	45.7	140	2,818
M3 × 4.5	1.8	3.3	4.5	6,725	12,580	257.6	93.1	93.1	203	2,818

CROSS ROLLER RAILS / CROSS BALL RAILS / CROSS ROLLER ASSEMBLIES



Nook Cross Roller Assemblies provide high rigidity in high precision applications.

LINEAR GUIDANCE

CROSS ROLLER / BALL RAILS & ASSEMBLIES



LINEAR MOTION - CROSS ROLLER / BALL RAILS

Model Number and Introduction	112
Accuracy and Character.....	113
Load Capacity and Loading Direction Safety Factor ..	114-115
Assembly Instructions	116
Operation Features	117

CROSS ROLLER RAILS

GRVP / GRV-S 01-02	118-119
GRV / GRV-S 03-04	120-121
GRV / GRV-S 06-09-12	122-123

CROSS ROLLER RAILS - PLASTIC RETAINER

GRVP / GRVP-S 01-02	124-125
GRVP / GRVP-S 03-04.....	126-127
GRVP / GRVP-S 06.....	128-129

CROSS BALL RAILS

GBV 01-02	130-131
GBV 03-04	132-133
GBV 06-09-12.....	134-135

CROSS ROLLER ASSEMBLIES

Model Number and Introduction	136-137
Accuracy Description.....	138
Rated Life Calculation of Table and Parameter Calculation Formula.....	138
Torque Calculation	139
Operation Instructions.....	139
Type A GRA / GRA-N 30-40-60	140-141
Type A GRA / GRA-N 80-100-145.....	142-143
Type B GRB / GRB-N 30-40-60	144-145
Type B GRB / GRB-N 80-100-145.....	146-147
Type C GRC / GRC-N 20-40	148-149
Type M GRM / GRM-N 30-40	150-151
Type M GRM / GRM-N 60	152-153
Type M GRM / GRM-N 80-100	154-155
Type H GRH / GRH-N 20-40.....	156-157
Type S GRS / GRS-N 20-40.....	158-159

MATERIAL COMPARISON 160

CRYOGENIC TECHNICAL INFORMATION 161

LUBRICATION COMPATIBILITY REQUEST 161

CROSS ROLLER / BALL RAILS & ASSEMBLIES

MODEL NUMBER AND INTRODUCTION

GRV Roller Bearings	GBV Ball Bearings	DIAMETER (mm)	LENGTH (mm)	MATERIAL
		01: Ø1.5 02: Ø2.0 03: Ø3.0 04: Ø4.0 06: Ø6.0 09: Ø9.0 12: Ø12.0	Length selection as specified	S : SU440C + Ni

Model Number Explanation

GR	V	01	-	20	-	S
Roller	Rail Type	Dia.		Length		Material

Model Number	MATERIAL			
	Rail	Retainer	Roller	Ball
GRV	SUJ2 (52100)	SUS304	SUJ2	X
GRV-S*	S : SU440C + Ni	SUS304	100Cr6	X
GBV	SUJ2 (52100)	Phosphor Bronze (C5191)	X	SUJ2

* GRV-S series is suitable for application in clean rooms.

CROSS ROLLER / CROSS BALL RAIL

Composed of two pieces of stainless steel rails with V-shaped grooves which been hardened and ground forming precise rolling elements. Cross roller rail moves with alternate 90 degrees rollers to accomplish high parallelism and high flatness. In construction, rolling elements are transmitted in cross-contact by precise roller and V-shaped grooves in rails, and in non-circulation.

APPLICATIONS

Widely used across a variety of applications where heavy duty or light duty is required. They are used in a variety of manufactured products such as:

- Measuring Instruments
- Printed Circuit Boards
- Drilling Machine
- Slide Table Used In Optical Measuring Instrument
- Precise Gauge In Optical Experiment
- Precision Fine Tuning Optical Stage
- Operation Mechanism
- Survey Device
- Precise Positioning Quantitative Movement X-Ray Device
- Micro-Hole Edm

LUBRICATION

All linear motion applications require proper lubrication. Abrasion and lack of lubrication will reduce life by 90%.

Function of lubrication:

1. Reduce friction between running parts.
2. Apply a light oil film on rolling surface to reduce abrasion of metal to extend life of rolling elements.
3. Coating on metal surface to prevent rust.

LINEAR GUIDANCE

CROSS ROLLER / BALL RAILS & ASSEMBLIES

GRV – ROLLER

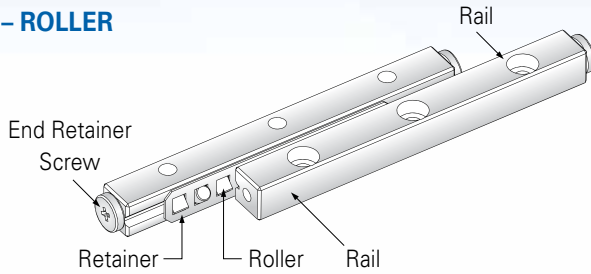

Composed of precise crossed rollers with hardened stainless steel forming V-shaped rail guides to create linear motion elements with high accuracy.

Limited stroke linear motion system with high rigidity, high load, and fast moment.

GBV – BALL

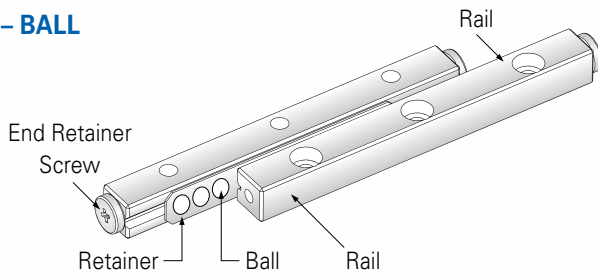

Composed of ball retainer combined with precision ball bearings matched with precision ground V-shaped grooved rails. Limited stroke linear motion system with low friction, light load and high accuracy.

ADVANTAGES

Suited for micro-movement applications due to small amount of frictional resistance, with almost no difference between starting friction resistance and dynamic friction resistance.

Stability in low speed applications: Even in the case of light loading, low to high speed variations are stable due to the low amount of frictional resistance.

High rigidity - high loading capacity applications: Compared between roller or ball rails. Roller rails have a higher capacity due to their larger contact area, less elasticity deformation, and non-circulation, and great effective number of units in contact.

Low noise: Nook linear motion cross roller rail has no circulated rotating, no noise occurred. Using roller with roller retainer makes no noise caused by contact friction in between each rolling unit moves alternately, to ensure a quiet movement motion.

ACCURACY LEVEL

ITEM	HIGH LEVEL	PRECISE LEVEL
	H	P
Parallelism of rolling plane to A & B	As shown in drawing below	
Allowable dimension tolerance to height V	0.02	0.01
Paired mutual tolerance to height V	0.01	0.005
Allowable dimension tolerance to width W	0	0
	-0.20	-0.10

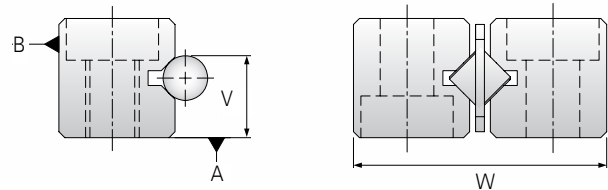

Rail length and parallelism of rolling plane

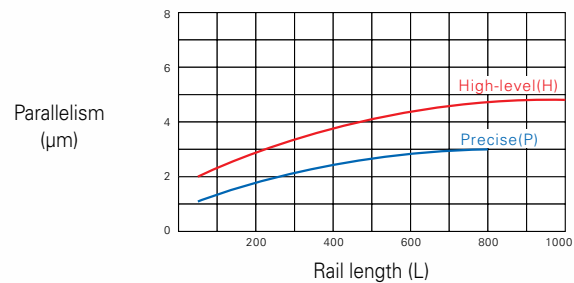

ACCURACY ALLOWABLE TOLERANCE

	LENGTH (mm)		STRAIGHTNESS
	Above	Below	(µm)
High Level (H)	—	50	2.0
	50	100	2.0
	100	160	3.0
	160	310	3.0
	310	510	4.0
	510	600	4.0
Precise Level (P)	—	50	1.0
	50	100	1.0
	100	160	2.0
	160	310	2.0
	310	510	3.0
	510	600	3.0

LOAD

LOAD DEFINITIONS

The load ratings are based on each roller/ball bearing element. When calculating actual rating, the number of rolling elements must be determined.

Roller/Ball Bearing Capacity The max usable load per rolling element.

Basic Dynamic Load Used when calculating life for each rolling element. Based on 50Km of travel.

Basic Static Load Rating Maximum impact load prior to causing permanent deformation for each rolling element.

STROKE AND ROLLER / BALL QUANTITY CALCULATIONS

When selecting Cross Roller or Ball Rails, several considerations must be made:

- Stroke Length
- Quantity of rolling elements (Roller or Ball)
- Accuracy
- Load capacity

Calculation of retainer length and roller quantity

The number of rolling elements is dependent on the retainer length. To calculate the number of rolling elements you must first calculate the retainer length. Retainer Length is the length of engagement between both side of the rail when fully extended.

Calculating the retainer length

$$L_R = L - \frac{S}{2}$$

Where:
 L_R = Retainer length, mm
 L = Rail length, mm
 S = Stroke length, mm

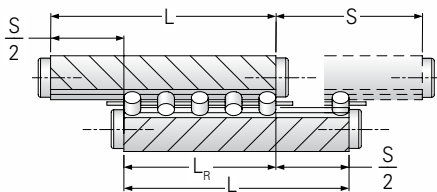

Calculating the number of rolling elements

$$R_n = \frac{L_R}{P_2} + 1$$

Where:
 R_n = Number of rolling elements (integer)
 L_R = Retainer length, mm
 P_2 = Catalog pitch length

CROSS ROLLER / BALL RAIL ASSEMBLY LOAD CALCULATIONS

Calculating Cross Roller / Ball Rail assembly load rating

$$F = R_n \times F_E$$

Where:
 F = Rail capacity
 R_n = Roller quantity
 F_E = Roller/Ball capacity (N) for each rolling element

Selecting the correct travel length

When selecting the appropriate rail assembly, the expected travel should be 80% of catalog Max Travel.

$$\text{Effective travel} = S \times .8$$

Where:
 S = Catalog Stroke Length, mm

LIFE CALCULATION

Basic dynamic load rating is based on 50km of travel. Use the formulas below to calculate equivalent life in given applications.

$$\text{Ball } L = (F_d \times F_v \times \frac{\sum C}{P})^{10/3} \times 50 \quad \text{Roller } L = (F_d \times F_v \times \frac{\sum C}{P})^3 \times 50$$

Where:
 L = Usage life (km)
 P = Loading
 F_d = Safety factor in loading direction
 F_v = Safety factor in variable loading

APPLICATION EXAMPLE

When using cross roller side by side, which specification should be chosen?

Specification.....GRV04
 Loading.....P = 4000N
 Stroke length.....SW = 120mm

Calculating the Retainer Length

$$L_R = 200\text{mm} - (120\text{mm}/2)$$

Where:
 $L_R = 140\text{mm}$

Calculating the number of rolling elements

$$R_n = 140\text{mm}/7 + 1$$

Where:
 R_n (integer) = 21

Calculating Assembly Load rating

$$F = 21 \times 390\text{N}$$

Where:
 $F = 8190\text{N}$
 Load ratio = $4000/8190 \times 100 = 48.84\%$

Calculating Travel length

$$\text{Maximum stroke } 154\text{mm} \times .8 = 123.3\text{mm}$$

LOAD CAPACITY & LOADING DIRECTION SAFETY FACTOR

LOAD CAPACITY OF CROSS BALL RAIL

CONDITION	SINGLE - AXIS USE	SINGLE - AXIS VERTICAL USE	DUAL - AXIS ABREAST USE
Loading direction			
Basic dynamic load rating ΣC	$B^{3/4} \times \cos \frac{\pi}{4} \times C$	$B^{3/4} \times 2^{7/9} \times \cos \frac{\pi}{4} \times C$	
Basic static load rating ΣC_0	$B \times \cos \frac{\pi}{4} \times C_0$	$B \times 2^{7/9} \times C_0$	

C = basic dynamic load rating (N) C₀ = basic static load rating (N) B = ball quantity in single row

LOAD CAPACITY OF CROSS ROLLER RAIL

CONDITION	SINGLE - AXIS USE	SINGLE - AXIS VERTICAL USE	DUAL - AXIS ABREAST USE
Loading direction			
Basic dynamic load rating ΣC	$C = (\frac{R}{2})^{3/4} \times C$	$C = (\frac{R}{2})^{3/4} \times C \times 2^{7/9}$	
Basic static load rating ΣC_0	$C_0 = \frac{R}{2} \times C_0$	$C_0 = R \times C_0$	

C = basic dynamic load rating (N) C₀ = basic static load rating (N) B = ball quantity in single row R/2 = Integer, no remainder

SAFETY FACTOR F_d IN LOADING DIRECTIONS

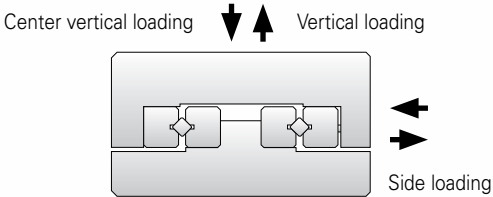

CLASSIFICATION	LOADING DIRECTION	F _d
Basic dynamic loading	Vertical	1.0
	Side	0.9
	Counter vertical	0.8
Basic static loading	Vertical	1.0
	Side	0.9
	Counter vertical	0.8

SAFETY FACTOR F_v IN VARIABLE LOADING

Running condition	F _v
Normal running	1 ~ 0.5
Smooth motion required	0.5 ~ 0.25
Vibration - shock	0.3 ~ 0.2

COMMON CONTACT FACTOR F_c IN SINGLE RAIL

Quantity of Linear systems assembled in a single shaft	Contact factor F _c
1	1.00
2	0.81
3	0.72
4	0.66
5	0.61

CROSS ROLLER / BALL RAILS & ASSEMBLIES

ASSEMBLY INSTRUCTIONS

1. Apply oil in low viscosity on contact planes, fix rail 1 - 3 with regular torque.

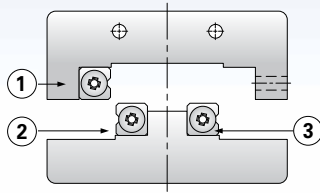

2. Temporarily lock rail in adjusted side 4.

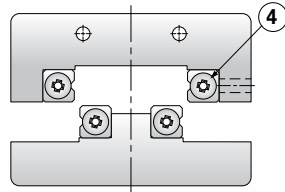

3. Disassemble end screw from end of one side, and carefully insert roller retainer to nearby center of the rail.

- Lock the end screw.
- Slowly move table back and forth to the rail end and adjust roller retainer position to rail center.

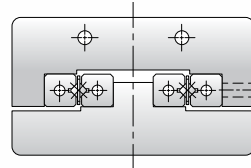

4. Fix gauges both in center and side of the table (level plane).

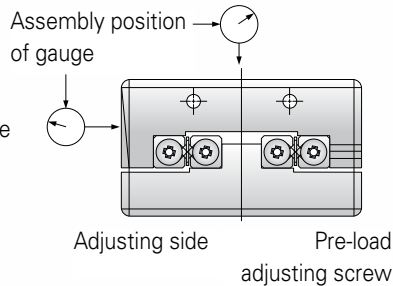

5. Move table to end of one side, and lock pre-load adjusting screw slightly.

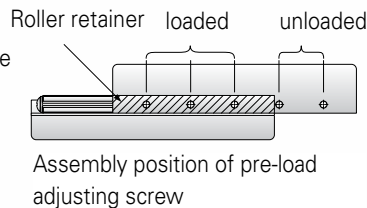

6. Move table to the end of the other side, as above description, and lock pre-load adjusting screw slightly.

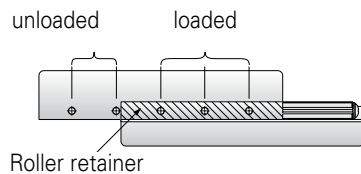

7. Return table to center and lock pre-loads adjusting screw slightly, ensuring that all clearance has been removed.

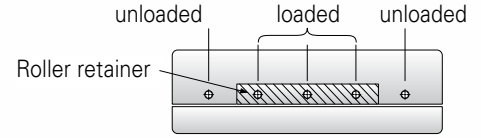

8. Finally securely lock the rail 4. As steps of screw adjustment, move table back and forth, then have the table over roller retainer, and lock screws in order.

APPLICATION EXAMPLES

Pre-load adjusting screw-set screw is used to do normal adjustment.

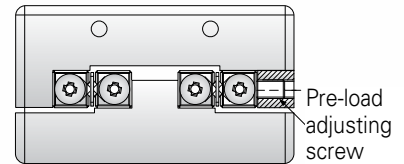

Use clamp to achieve requirement of accuracy and rigidity.

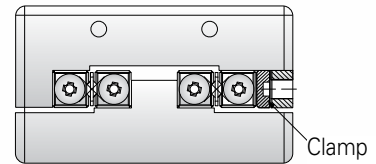

Use taper block to meet special requirement of high rigidity and high accuracy.

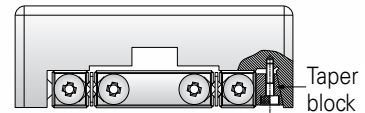

INSTALLATION NOTES

In order for Nook linear motion cross roller rails to function, it is recommended to install assembly planes with accuracy same as parallelism precisely processed in linear motion cross roller rail.

All burrs, dent, dust, miscellaneous objects on the rail of table and base need to be cleaned spotlessly and keep eyes on assembly operation application.

Preload adjustment, too much preload would cause press damage to reduce life; it's normally recommended to use zero or tiny preload.

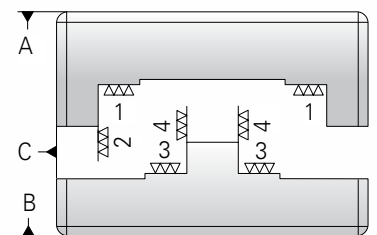

Accuracy of installation assembly plane

LINEAR GUIDANCE

CROSS ROLLER / BALL RAILS & ASSEMBLIES

PRE-LOAD ADJUSTING SCREW LOCK TORQUE (Unit/N · m)

SPECIFICATION	SCREW SIZE	LOCKTORQUE
GRV1	M2	0.008
GRV2	M3	0.012
GRV3	M4	0.05
GRV4	M4	0.08
GRV6	M5	0.2
GRV9	M6	0.4

FIX SCREW LOCK TORQUE (Unit/N · m)

SPECIFICATION	LOCKTORQUE
M2	0.28
M3	1.02
M4	2.37
M5	4.77
M6	8.14
M8	19.69

Use steel alloy screw.

RESERVED LOCK SCREW

When Nook linear motion cross roller rail are used in sink screw hole assemblies, it is recommended to use reserved lock screw.

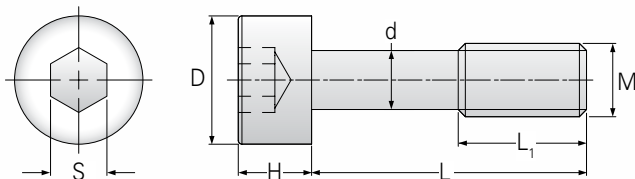
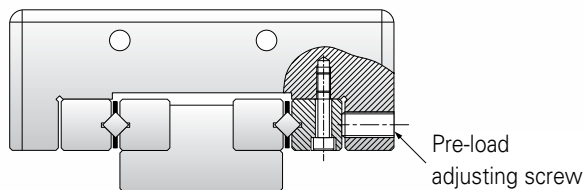

M	d	D	H	L	L ₁	S	CROSS ROLLER RAIL
M3	2.3	5	3	12	5	2.5	GRV3
M4	3.1	5.8	4	15	7	3	GRV4
M5	3.9	8	5	20	8	4	GRV6
M6	4.6	8.5	6	30	12	5	GRV9
M8	6.25	11.3	8	40	17	6	GRV12

Unit = mm

OPERATION FEATURES

Misalignment

Operating Cross Roller/Ball Rails and Assemblies with improper alignment of assembly will reduce life and accuracy.

Retainer Deviation

Nook linear motion cross roller rail, in high speed, off-center load, or vibration load may cause retainer deviation.

End Stops

Ends of linear motion rail can be provided with end screws. This feature is intended to prevent retainer falling off during handling. It is not intended for use as a stopping mechanism.

Overload

Overloading a Cross Roller/Ball Rail, or applying an unusual collision or hard stop will cause permanent indentation in V-groove and rollers/ball bearings. This will cause non-smooth motion and effect accuracy.

Matched Sets

Cross roller rail accuracy is made by matching sets as unit to precisely control its error range. Different sets of cross roller/ball rails mixed in use may result in accuracy variation.

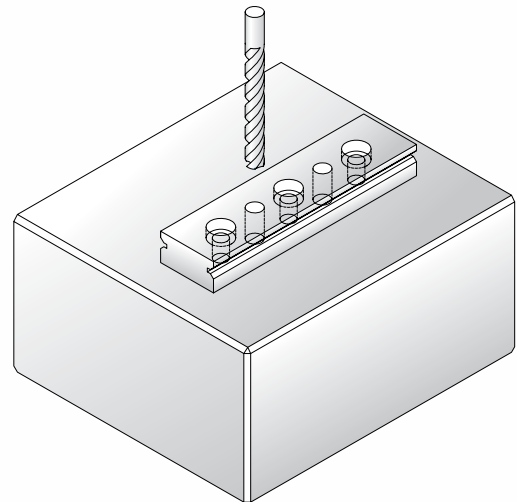

GRV / GRV-S (STAINLESS) ROLLER SIZE 01 - 02

RAIL LENGTH 20 THRU 180

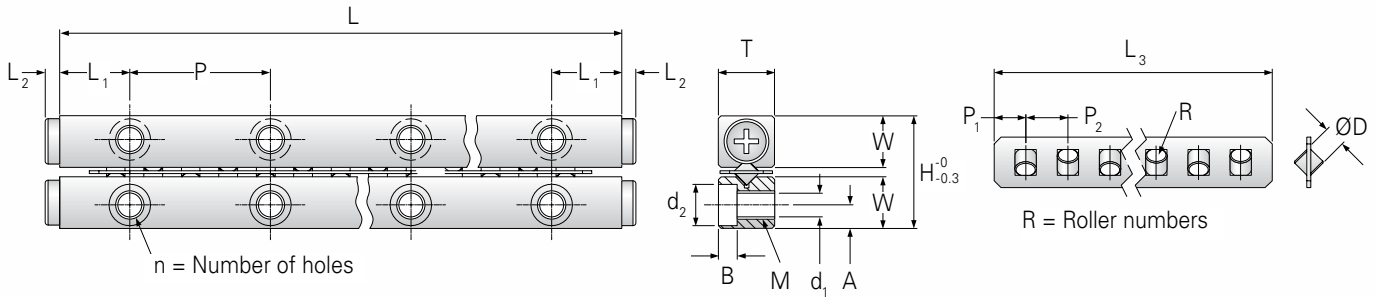

Model		Max. Stroke (mm)	MAIN DIMENSIONS (mm)								RETAINER DIMENSIONS (mm)				
Standard	Stainless		H	T	W	L	n	P	L ₁	L ₂	ØD	L ₃	R	P ₁	P ₂
GRV01 - 20	GRV01 - 20 - S	13	8.5	4	3.9	20	4	10	5	0.5	Ø1.5	15.8	5	1.9	3
GRV01 - 30	GRV01 - 30 - S	21	8.5	4	3.9	30	6	10	5	0.5	Ø1.5	21.8	7	1.9	3
GRV01 - 40	GRV01 - 40 - S	29	8.5	4	3.9	40	8	10	5	0.5	Ø1.5	27.8	9	1.9	3
GRV01 - 50	GRV01 - 50 - S	37	8.5	4	3.9	50	10	10	5	0.5	Ø1.5	33.8	11	1.9	3
GRV01 - 60	GRV01 - 60 - S	45	8.5	4	3.9	60	12	10	5	0.5	Ø1.5	39.8	13	1.9	3
GRV01 - 70	GRV01 - 70 - S	53	8.5	4	3.9	70	14	10	5	0.5	Ø1.5	45.8	15	1.9	3
GRV01 - 80	GRV01 - 80 - S	61	8.5	4	3.9	80	16	10	5	0.5	Ø1.5	51.8	17	1.9	3
GRV02 - 30	GRV02 - 30 - S	24	12	6	5.5	30	4	15	7.5	0.8	Ø2	21.6	5	2.8	4
GRV02 - 45	GRV02 - 45 - S	30	12	6	5.5	45	6	15	7.5	0.8	Ø2	33.6	8	2.8	4
GRV02 - 60	GRV02 - 60 - S	44	12	6	5.5	60	8	15	7.5	0.8	Ø2	41.6	10	2.8	4
GRV02 - 75	GRV02 - 75 - S	58	12	6	5.5	75	10	15	7.5	0.8	Ø2	49.6	12	2.8	4
GRV02 - 90	GRV02 - 90 - S	72	12	6	5.5	90	12	15	7.5	0.8	Ø2	57.6	14	2.8	4
GRV02 - 105	GRV02 - 105 - S	86	12	6	5.5	105	14	15	7.5	0.8	Ø2	65.6	16	2.8	4
GRV02 - 120	GRV02 - 120 - S	100	12	6	5.5	120	16	15	7.5	0.8	Ø2	73.6	18	2.8	4
GRV02 - 135	GRV02 - 135 - S	106	12	6	5.5	135	18	15	7.5	0.8	Ø2	85.6	21	2.8	4
GRV02 - 150	GRV02 - 150 - S	120	12	6	5.5	150	20	15	7.5	0.8	Ø2	93.6	23	2.8	4
GRV02 - 165	GRV02 - 165 - S	134	12	6	5.5	165	22	15	7.5	0.8	Ø2	101.6	25	2.8	4
GRV02 - 180	GRV02 - 180 - S	148	12	6	5.5	180	24	15	7.5	0.8	Ø2	109.6	27	2.8	4

Model Number Explanation

GR **V** **01** - **20** - **S**
 Roller Rail Type Size Length Stainless Steel

LINEAR GUIDANCE

CROSS ROLLER RAIL

MATERIAL SPECIFICATION

Model number	Rail	Roller	Retainer
GRV	SUJ2		SUS304
GRV-S	SUS440C + Ni	100Cr6	

GRV-S no precision ground finish to V - groove surface of the rail.



Part number includes two sets of rails

	MOUNTING DIMENSIONS (mm)					BASIC LOAD RATINGS PER ROLLER BEARING*		CAPACITY PER ROLLER BEARING* (N)	WEIGHT (g) / 2 PIECES	
	A	M	d ₁	d ₂	B	Dynamic C (N)	Static C ₀ (N)		Standard	Stainless
	1.8	M2	1.65	3	1.4	125	144	48	4	4
	1.8	M2	1.65	3	1.4	125	144	48	6	7
	1.8	M2	1.65	3	1.4	125	144	48	8	9
	1.8	M2	1.65	3	1.4	125	144	48	10	11
	1.8	M2	1.65	3	1.4	125	144	48	12	13
	1.8	M2	1.65	3	1.4	125	144	48	14	16
	1.8	M2	1.65	3	1.4	125	144	48	16	17
	2.5	M3	2.55	4.4	2	293	292	97	13	14
	2.5	M3	2.55	4.4	2	293	292	97	20	21
	2.5	M3	2.55	4.4	2	293	292	97	26	28
	2.5	M3	2.55	4.4	2	293	292	97	32	35
	2.5	M3	2.55	4.4	2	293	292	97	39	42
	2.5	M3	2.55	4.4	2	293	292	97	45	48
	2.5	M3	2.55	4.4	2	293	292	97	51	55
	2.5	M3	2.55	4.4	2	293	292	97	58	62
	2.5	M3	2.55	4.4	2	293	292	97	64	69
	2.5	M3	2.55	4.4	2	293	292	97	70	76
	2.5	M3	2.55	4.4	2	293	292	97	77	82

* For calculating cross roller rail load rating, see page 114.

CROSS ROLLER RAILS

GRV / GRV-S (STAINLESS) ROLLER SIZE 03 - 04

RAIL LENGTH 50 THRU 480

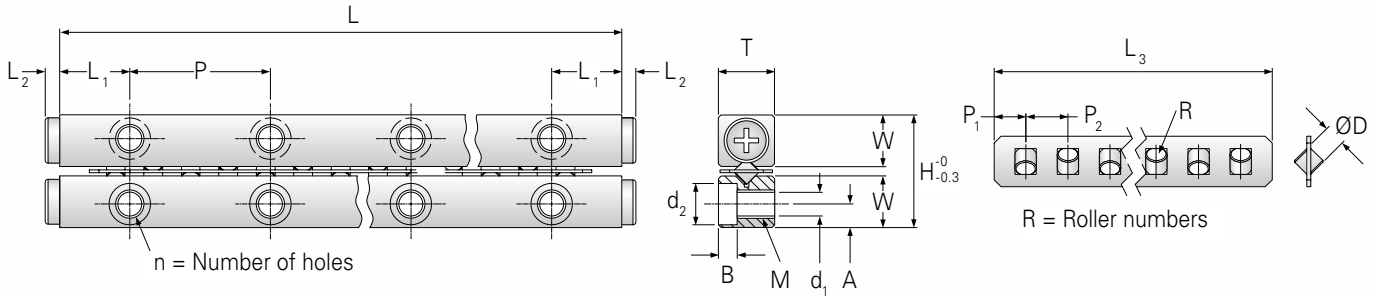

Model		Max. Stroke (mm)	MAIN DIMENSIONS (mm)								RETAINER DIMENSIONS (mm)				
Standard	Stainless		H	T	W	L	n	P	L ₁	L ₂	ØD	L ₃	R	P ₁	P ₂
GRV03 - 50	GRV03 - 50 - S	34	18	8	8.3	50	4	25	12.5	0.8	Ø3	36.4	7	3.2	5
GRV03 - 75	GRV03 - 75 - S	54	18	8	8.3	75	6	25	12.5	0.8	Ø3	51.4	10	3.2	5
GRV03 - 100	GRV03 - 100 - S	74	18	8	8.3	100	8	25	12.5	0.8	Ø3	66.4	13	3.2	5
GRV03 - 125	GRV03 - 125 - S	104	18	8	8.3	125	10	25	12.5	0.8	Ø3	76.4	15	3.2	5
GRV03 - 150	GRV03 - 150 - S	124	18	8	8.3	150	12	25	12.5	0.8	Ø3	91.4	18	3.2	5
GRV03 - 175	GRV03 - 175 - S	144	18	8	8.3	175	14	25	12.5	0.8	Ø3	106.4	21	3.2	5
GRV03 - 200	GRV03 - 200 - S	164	18	8	8.3	200	16	25	12.5	0.8	Ø3	121.4	24	3.2	5
GRV03 - 225	GRV03 - 225 - S	184	18	8	8.3	225	18	25	12.5	0.8	Ø3	136.4	27	3.2	5
GRV03 - 250	GRV03 - 250 - S	204	18	8	8.3	250	20	25	12.5	0.8	Ø3	151.4	30	3.2	5
GRV03 - 275	GRV03 - 275 - S	224	18	8	8.3	275	22	25	12.5	0.8	Ø3	166.4	33	3.2	5
GRV03 - 300	GRV03 - 300 - S	244	18	8	8.3	300	24	25	12.5	0.8	Ø3	181.4	36	3.2	5
GRV04 - 80	GRV04 - 80 - S	54	22	11	10	80	4	40	20	1	Ø4	57.6	8	4.3	7
GRV04 - 120	GRV04 - 120 - S	92	22	11	10	120	6	40	20	1	Ø4	78.6	11	4.3	7
GRV04 - 160	GRV04 - 160 - S	130	22	11	10	160	8	40	20	1	Ø4	99.6	14	4.3	7
GRV04 - 200	GRV04 - 200 - S	154	22	11	10	200	10	40	20	1	Ø4	127.6	18	4.3	7
GRV04 - 240	GRV04 - 240 - S	192	22	11	10	240	12	40	20	1	Ø4	148.6	21	4.3	7
GRV04 - 280	GRV04 - 280 - S	230	22	11	10	280	14	40	20	1	Ø4	169.6	24	4.3	7
GRV04 - 320	GRV04 - 320 - S	254	22	11	10	320	16	40	20	1	Ø4	197.6	28	4.3	7
GRV04 - 360	GRV04 - 360 - S	292	22	11	10	360	18	40	20	1	Ø4	218.6	31	4.3	7
GRV04 - 400	GRV04 - 400 - S	330	22	11	10	400	20	40	20	1	Ø4	239.6	34	4.3	7
GRV04 - 440	GRV04 - 440 - S	354	22	11	10	440	22	40	20	1	Ø4	267.6	38	4.3	7
GRV04 - 480	GRV04 - 480 - S	392	22	11	10	480	24	40	20	1	Ø4	288.6	41	4.3	7

Model Number Explanation

GR **V** **03** - **50** - **S**
 Roller Rail Type Size Length Stainless Steel

LINEAR GUIDANCE

CROSS ROLLER RAIL

MATERIAL SPECIFICATION

Model number	Rail	Roller	Retainer
GRV	SUJ2		SUS304
GRV-S	SUS440C + Ni	100Cr6	

GRV-S no precision ground finish to V - groove surface of the rail.



Part number includes two sets of rails

	MOUNTING DIMENSIONS (mm)					BASIC LOAD RATINGS PER ROLLER BEARING*		CAPACITY PER ROLLER BEARING* (N)	WEIGHT (g) / 2 PIECES	
	A	M	d ₁	d ₂	B	Dynamic C (N)	Static C ₀ (N)		Standard	Stainless
	3.5	M4	3.3	6	3.1	638	761	254	46	49
	3.5	M4	3.3	6	3.1	638	761	254	68	73
	3.5	M4	3.3	6	3.1	638	761	254	90	97
	3.5	M4	3.3	6	3.1	638	761	254	112	120
	3.5	M4	3.3	6	3.1	638	761	254	134	144
	3.5	M4	3.3	6	3.1	638	761	254	157	168
	3.5	M4	3.3	6	3.1	638	761	254	179	191
	3.5	M4	3.3	6	3.1	638	761	254	201	215
	3.5	M4	3.3	6	3.1	638	761	254	223	239
	3.5	M4	3.3	6	3.1	638	761	254	245	262
	3.5	M4	3.3	6	3.1	638	761	254	267	286
	4.5	M5	4.3	7.5	4.1	1230	1170	390	122	130
	4.5	M5	4.3	7.5	4.1	1230	1170	390	180	193
	4.5	M5	4.3	7.5	4.1	1230	1170	390	238	254
	4.5	M5	4.3	7.5	4.1	1230	1170	390	296	317
	4.5	M5	4.3	7.5	4.1	1230	1170	390	355	380
	4.5	M5	4.3	7.5	4.1	1230	1170	390	413	442
	4.5	M5	4.3	7.5	4.1	1230	1170	390	472	505
	4.5	M5	4.3	7.5	4.1	1230	1170	390	530	568
	4.5	M5	4.3	7.5	4.1	1230	1170	390	589	631
	4.5	M5	4.3	7.5	4.1	1230	1170	390	647	694
	4.5	M5	4.3	7.5	4.1	1230	1170	390	706	756

* For calculating cross roller rail load rating, see page 114.

CROSS ROLLER RAILS

GRV / GRV-S (STAINLESS) ROLLER SIZE 06 - 09 - 12

RAIL LENGTH 100 THRU 600

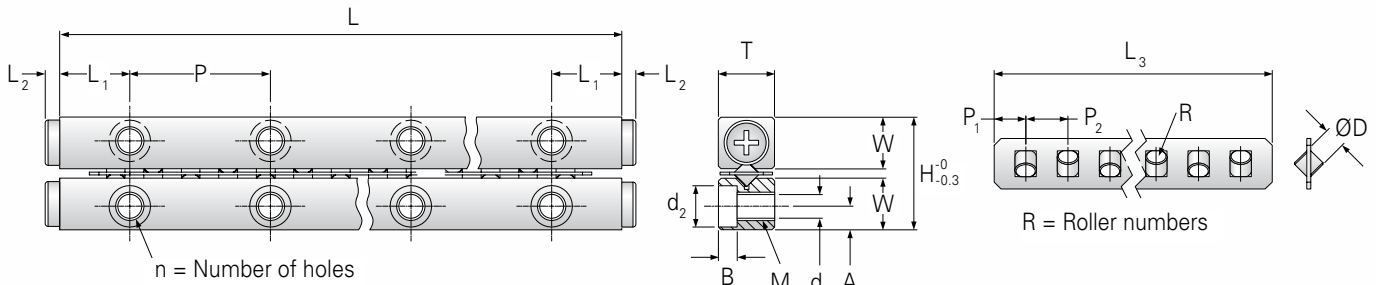

Model		Max. Stroke (mm)	MAIN DIMENSIONS (mm)								RETAINER DIMENSIONS (mm)				
Standard	Stainless		H	T	W	L	n	P	L ₁	L ₂	ØD	L ₃	B	P ₁	P ₂
GRV06 - 100	GRV06 - 100 - S	80	31	15	14	100	4	50	25	1	Ø6	64.8	7	5.4	9
GRV06 - 150	GRV06 - 150 - S	108	31	15	14	150	6	50	25	1	Ø6	100.8	11	5.4	9
GRV06 - 200	GRV06 - 200 - S	154	31	15	14	200	8	50	25	1	Ø6	127.8	14	5.4	9
GRV06 - 250	GRV06 - 250 - S	200	31	15	14	250	10	50	25	1	Ø6	154.8	17	5.4	9
GRV06 - 300	GRV06 - 300 - S	246	31	15	14	300	12	50	25	1	Ø6	181.8	20	5.4	9
GRV06 - 350	GRV06 - 350 - S	274	31	15	14	350	14	50	25	1	Ø6	217.8	24	5.4	9
GRV06 - 400	GRV06 - 400 - S	320	31	15	14	400	16	50	25	1	Ø6	244.8	27	5.4	9
GRV06 - 450	GRV06 - 450 - S	366	31	15	14	450	18	50	25	1	Ø6	271.8	30	5.4	9
GRV06 - 500	GRV06 - 500 - S	412	31	15	14	500	20	50	25	1	Ø6	298.8	33	5.4	9
GRV06 - 550	GRV06 - 550 - S	458	31	15	14	550	22	50	25	1	Ø6	325.8	36	5.4	9
GRV06 - 600	GRV06 - 600 - S	486	31	15	14	600	24	50	25	1	Ø6	361.8	40	5.4	9
GRV09 - 200	GRV09 - 200 - S	158	44	22	20.2	200	4	100	50	1	Ø9	130	9	9	14
GRV09 - 300	GRV09 - 300 - S	246	44	22	20.2	300	6	100	50	1	Ø9	186	13	9	14
GRV09 - 400	GRV09 - 400 - S	306	44	22	20.2	400	8	100	50	1	Ø9	256	18	9	14
GRV09 - 500	GRV09 - 500 - S	394	44	22	20.2	500	10	100	50	1	Ø9	312	22	9	14
GRV09 - 600	GRV09 - 600 - S	482	44	22	20.2	600	12	100	50	1	Ø9	368	26	9	14
GRV12 - 200	GRV12 - 200 - S	160	58	28	26.9	200	14	100	50	1	Ø12	130	7	11	18
GRV12 - 300	GRV12 - 300 - S	216	58	28	26.9	300	6	100	50	1	Ø12	202	11	11	18
GRV12 - 400	GRV12 - 400 - S	308	58	28	26.9	400	8	100	50	1	Ø12	256	14	11	18
GRV12 - 500	GRV12 - 500 - S	400	58	28	26.9	500	10	100	50	1	Ø12	310	17	11	18
GRV12 - 600	GRV12 - 600 - S	492	58	28	26.9	600	12	100	50	1	Ø12	364	20	11	18

Model Number Explanation

GR **V** **06** - **100** - **S**
 Roller Rail Type Size Length Stainless Steel

MATERIAL SPECIFICATION

Model number	Rail	Roller	Retainer
GRV	SUJ2		SUS304
GRV-S	SUS440C + Ni	100Cr6	

GRV-S no precision ground finish to V - groove surface of the rail.



Part number includes two sets of rails

	MOUNTING DIMENSIONS (mm)					BASIC LOAD RATINGS PER ROLLER BEARING*		CAPACITY PER ROLLER BEARING*	WEIGHT (g) / 2 PIECES	
	A	M	d ₁	d ₂	b	Dynamic C (N)	Static C ₀ (N)	(N)	Standard	Stainless
	6	M6	5.3	9.5	5.2	2,570	2,632	877	921	311
	6	M6	5.3	9.5	5.2	2,570	2,632	877	435	466
	6	M6	5.3	9.5	5.2	2,570	2,632	877	577	618
	6	M6	5.3	9.5	5.2	2,570	2,632	877	721	773
	6	M6	5.3	9.5	5.2	2,570	2,632	877	864	925
	6	M6	5.3	9.5	5.2	2,570	2,632	877	1,006	1,078
	6	M6	5.3	9.5	5.2	2,570	2,632	877	1,150	1,232
	6	M6	5.3	9.5	5.2	2,570	2,632	877	1,292	1,385
	6	M6	5.3	9.5	5.2	2,570	2,632	877	1,436	1,539
	6	M6	5.3	9.5	5.2	2,570	2,632	877	1,579	1,691
	6	M6	5.3	9.5	5.2	2,570	2,632	877	1,273	1,846
	9	M8	6.8	10.5	6.2	7,190	2,774	2,425	1,267	1,356
	9	M8	6.8	10.5	6.2	7,190	2,774	2,425	1,891	2,025
	9	M8	6.8	10.5	6.2	7,190	2,774	2,425	2,509	2,688
	9	M8	6.8	10.5	6.2	7,190	2,774	2,425	3,133	3,356
	9	M8	6.8	10.5	6.2	7,190	2,774	2,425	3,756	4,025
	12	M10	8.5	13.5	8.2	14,700	13,187	4,396	2,114	2,262
	12	M10	8.5	13.5	8.2	14,700	13,187	4,396	3,161	3,384
	12	M10	8.5	13.5	8.2	14,700	13,187	4,396	4,195	4,493
	12	M10	8.5	13.5	8.2	14,700	13,187	4,396	5,242	5,615
	12	M10	8.5	13.5	8.2	14,700	13,187	4,396	6,276	6,724

* For calculating cross roller rail load rating, see page 114.

MATERIAL SPECIFICATION

Model number	Rail	Roller	Retainer
GRVP	SUJ2		POM plastic
GRVP-S	SUS440C + Ni	100Cr6	

GRVP-S no precision ground finish to V - groove surface of the rail.



Part number includes two sets of rails

	MOUNTING DIMENSIONS (mm)					BASIC LOAD RATINGS PER ROLLER BEARING*		CAPACITY PER ROLLER BEARING* (N)	WEIGHT (g) / 2 PIECES	
	A	M	d ₁	d ₂	B	Dynamic C (N)	Static C ₀ (N)		Standard	Stainless
	1.8	M2	1.65	3	1.4	125	144	48	4	4
	1.8	M2	1.65	3	1.4	125	144	48	6	7
	1.8	M2	1.65	3	1.4	125	144	48	8	9
	1.8	M2	1.65	3	1.4	125	144	48	10	11
	1.8	M2	1.65	3	1.4	125	144	48	12	13
	1.8	M2	1.65	3	1.4	125	144	48	14	16
	1.8	M2	1.65	3	1.4	125	144	48	16	17
	2.5	M3	2.55	4.4	2	293	292	97	13	14
	2.5	M3	2.55	4.4	2	293	292	97	20	21
	2.5	M3	2.55	4.4	2	293	292	97	26	28
	2.5	M3	2.55	4.4	2	293	292	97	32	35
	2.5	M3	2.55	4.4	2	293	292	97	39	42
	2.5	M3	2.55	4.4	2	293	292	97	45	48
	2.5	M3	2.55	4.4	2	293	292	97	51	55
	2.5	M3	2.55	4.4	2	293	292	97	58	62
	2.5	M3	2.55	4.4	2	293	292	97	64	69
	2.5	M3	2.55	4.4	2	293	292	97	70	76
	2.5	M3	2.55	4.4	2	293	292	97	77	82

* For calculating cross roller rail load rating, see page 114.

LINEAR GUIDANCE

CROSS ROLLER RAIL

MATERIAL SPECIFICATION

Model number	Rail	Roller	Retainer
GRVP	SUJ2		POM plastic
GRVP-S	SUS440C + Ni	100Cr6	

GRVP-S no precision ground finish to V - groove surface of the rail.



Part number includes two sets of rails

	MOUNTING DIMENSIONS (mm)					BASIC LOAD RATINGS PER ROLLER BEARING*		CAPACITY PER ROLLER BEARING* (N)	WEIGHT (g) / 2 PIECES	
	A	M	d ₁	d ₂	B	Dynamic C (N)	Static C ₀ (N)		Standard	Stainless
	3.5	M4	3.3	6	3.1	638	761	254	46	49
	3.5	M4	3.3	6	3.1	638	761	254	68	73
	3.5	M4	3.3	6	3.1	638	761	254	90	97
	3.5	M4	3.3	6	3.1	638	761	254	112	120
	3.5	M4	3.3	6	3.1	638	761	254	134	144
	3.5	M4	3.3	6	3.1	638	761	254	157	168
	3.5	M4	3.3	6	3.1	638	761	254	179	191
	3.5	M4	3.3	6	3.1	638	761	254	201	215
	3.5	M4	3.3	6	3.1	638	761	254	223	239
	3.5	M4	3.3	6	3.1	638	761	254	245	262
	3.5	M4	3.3	6	3.1	638	761	254	267	286
	4.5	M5	4.3	7.5	4.1	1230	1170	390	122	130
	4.5	M5	4.3	7.5	4.1	1230	1170	390	180	193
	4.5	M5	4.3	7.5	4.1	1230	1170	390	238	254
	4.5	M5	4.3	7.5	4.1	1230	1170	390	296	317
	4.5	M5	4.3	7.5	4.1	1230	1170	390	355	380
	4.5	M5	4.3	7.5	4.1	1230	1170	390	413	442
	4.5	M5	4.3	7.5	4.1	1230	1170	390	472	505
	4.5	M5	4.3	7.5	4.1	1230	1170	390	530	568
	4.5	M5	4.3	7.5	4.1	1230	1170	390	589	631
	4.5	M5	4.3	7.5	4.1	1230	1170	390	647	694
	4.5	M5	4.3	7.5	4.1	1230	1170	390	706	756

* For calculating cross roller rail load rating, see page 114.

CROSS ROLLER RAILS

LINEAR GUIDANCE

CROSS ROLLER RAIL

MATERIAL SPECIFICATION

Model number	Rail	Roller	Retainer
GRVP	SUJ2		POM plastic
GRVP-S	SUS440C + Ni	100Cr6	

GRVP-S no precision ground finish to V - groove surface of the rail.



Part number includes two sets of rails

MOUNTING DIMENSIONS (mm)						BASIC LOAD RATINGS PER ROLLER BEARING*		CAPACITY PER ROLLER BEARING*	WEIGHT (g) / 2 PIECES	
A	M	d ₁	d ₂	b		Dynamic C (N)	Static C ₀ (N)	(N)	Standard	Stainless
6	M6	5.3	9.5	5.2		2,570	2,632	877	287	311
6	M6	5.3	9.5	5.2		2,570	2,632	877	435	466
6	M6	5.3	9.5	5.2		2,570	2,632	877	577	618
6	M6	5.3	9.5	5.2		2,570	2,632	877	721	773
6	M6	5.3	9.5	5.2		2,570	2,632	877	864	925
6	M6	5.3	9.5	5.2		2,570	2,632	877	1,006	1,078
6	M6	5.3	9.5	5.2		2,570	2,632	877	1,150	1,232
6	M6	5.3	9.5	5.2		2,570	2,632	877	1,292	1,385
6	M6	5.3	9.5	5.2		2,570	2,632	877	1,436	1,539
6	M6	5.3	9.5	5.2		2,570	2,632	877	1,579	1,691
6	M6	5.3	9.5	5.2		2,570	2,632	877	1,273	1,846

* For calculating cross roller rail load rating, see page 114.

GBV BALL SIZE 01 - 02
RAIL LENGTH 20 THRU 180

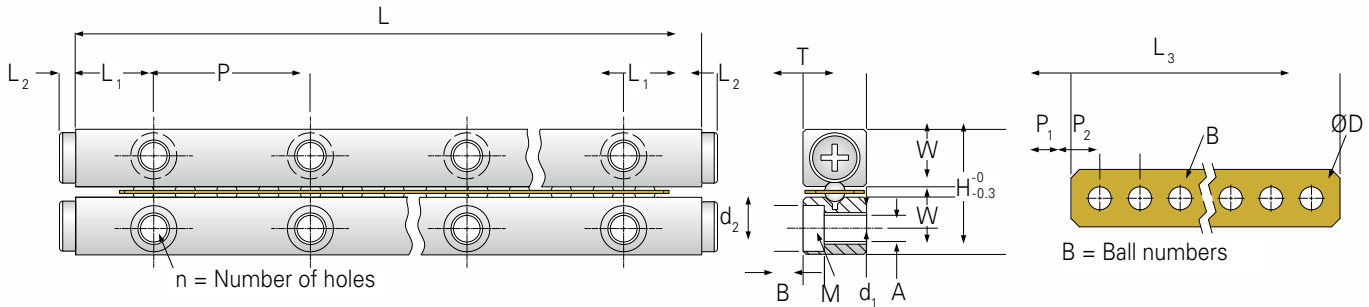

Model	Max. Stroke (mm)	MAIN DIMENSIONS (mm)								RETAINER DIMENSIONS (mm)				
		H	T	W	L	n	P	L ₁	L ₂	ØD	L ₃	R	P ₁	P ₂
GBV01 - 20	13	8.5	4	3.9	20	4	10	5	1.3	Ø1.5	15.5	5	1.75	3
GBV01 - 30	21	8.5	4	3.9	30	6	10	5	1.3	Ø1.5	21.5	7	1.75	3
GBV01 - 40	29	8.5	4	3.9	40	8	10	5	1.3	Ø1.5	27.5	9	1.75	3
GBV01 - 50	37	8.5	4	3.9	50	10	10	5	1.3	Ø1.5	33.5	11	1.75	3
GBV01 - 60	45	8.5	4	3.9	60	12	10	5	1.3	Ø1.5	39.5	13	1.75	3
GBV01 - 70	53	8.5	4	3.9	70	14	10	5	1.3	Ø1.5	45.5	15	1.75	3
GBV01 - 80	61	8.5	4	3.9	80	16	10	5	1.3	Ø1.5	51.5	17	1.75	3
GBV02 - 30	24	12	6	5.5	30	4	15	7.5	1.5	Ø2	20.6	5	2.3	4
GBV02 - 45	30	12	6	5.5	45	6	15	7.5	1.5	Ø2	32.6	8	2.3	4
GBV02 - 60	44	12	6	5.5	60	8	15	7.5	1.5	Ø2	40.6	10	2.3	4
GBV02 - 75	58	12	6	5.5	75	10	15	7.5	1.5	Ø2	48.6	12	2.3	4
GBV02 - 90	72	12	6	5.5	90	12	15	7.5	1.5	Ø2	56.6	14	2.3	4
GBV02 - 105	86	12	6	5.5	105	14	15	7.5	1.5	Ø2	64.6	16	2.3	4
GBV02 - 120	100	12	6	5.5	120	16	15	7.5	1.5	Ø2	72.6	18	2.3	4
GBV02 - 135	106	12	6	5.5	135	18	15	7.5	1.5	Ø2	84.6	21	2.3	4
GBV02 - 150	120	12	6	5.5	150	20	15	7.5	1.5	Ø2	92.6	23	2.3	4
GBV02 - 165	134	12	6	5.5	165	22	15	7.5	1.5	Ø2	100.6	25	2.3	4
GBV02 - 180	148	12	6	5.5	180	24	15	7.5	1.5	Ø2	108.6	27	2.3	4

Model Number Explanation

GB V 01 - 20
Ball Rail Type Size Length

LINEAR GUIDANCE

CROSS BALL RAIL

MATERIAL SPECIFICATION

Model number	Rail	Roller	Retainer
GBV	SUJ2		Phosphor Bronze (C5191)

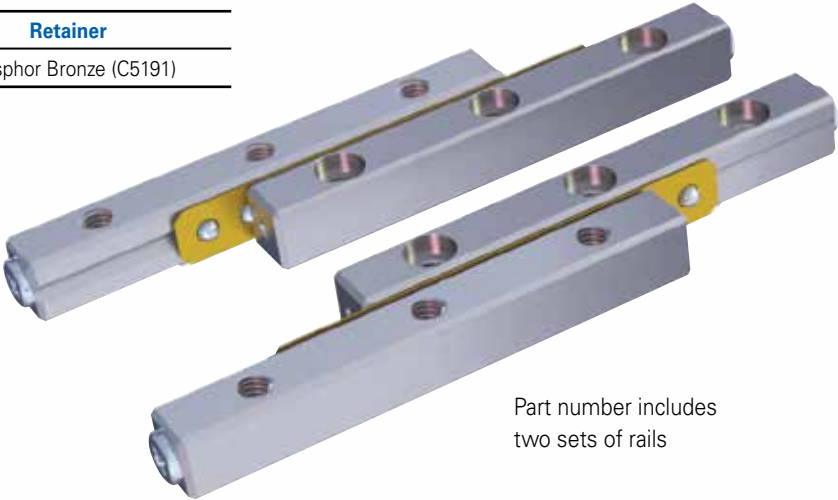

Part number includes two sets of rails

	MOUNTING DIMENSIONS (mm)					BASIC LOAD RATINGS PER BALL BEARING*		CAPACITY PER BALL BEARING* (N)	WEIGHT (g) / 2 PIECES Standard
	A	M	d ₁	d ₂	B	Dynamic C (N)	Static C ₀ (N)		
	1.8	M2	1.65	3	1.4	7.6	21	7.0	4
	1.8	M2	1.65	3	1.4	7.6	21	7.0	6
	1.8	M2	1.65	3	1.4	7.6	21	7.0	8
	1.8	M2	1.65	3	1.4	7.6	21	7.0	10
	1.8	M2	1.65	3	1.4	7.6	21	7.0	12
	1.8	M2	1.65	3	1.4	7.6	21	7.0	14
	1.8	M2	1.65	3	1.4	7.6	21	7.0	16
	2.5	M3	2.55	4.4	2	12	37	12.3	13
	2.5	M3	2.55	4.4	2	12	37	12.3	20
	2.5	M3	2.55	4.4	2	12	37	12.3	26
	2.5	M3	2.55	4.4	2	12	37	12.3	32
	2.5	M3	2.55	4.4	2	12	37	12.3	39
	2.5	M3	2.55	4.4	2	12	37	12.3	45
	2.5	M3	2.55	4.4	2	12	37	12.3	51
	2.5	M3	2.55	4.4	2	12	37	12.3	58
	2.5	M3	2.55	4.4	2	12	37	12.3	64
	2.5	M3	2.55	4.4	2	12	37	12.3	70
	2.5	M3	2.55	4.4	2	12	37	12.3	77

* For calculating cross ball rail load rating, see page 114.

CROSS BALL RAILS

GBV BALL SIZE 03 - 04
RAIL LENGTH 50 THRU 480

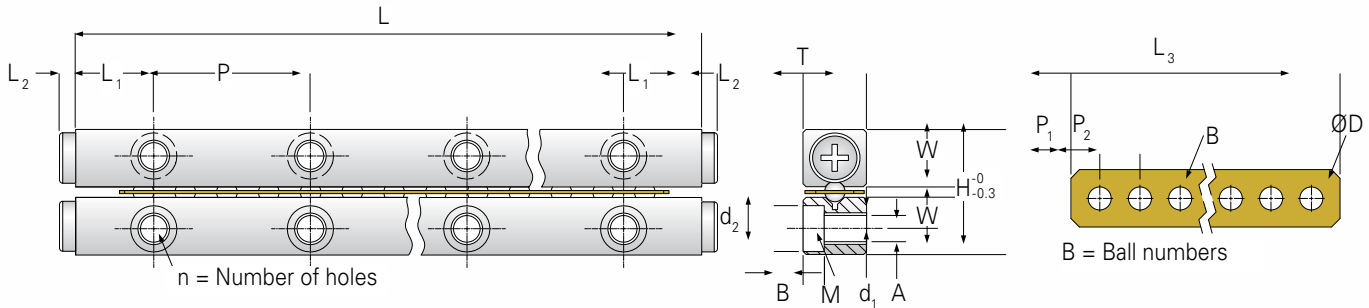

Model	Max. Stroke (mm)	MAIN DIMENSIONS (mm)								RETAINER DIMENSIONS (mm)				
		H	T	W	L	n	P	L ₁	L ₂	ØD	L ₃	R	P ₁	P ₂
GBV03 - 50	34	18	8	8.3	50	4	25	12.5	2	Ø3	35.7	7	2.86	5
GBV03 - 75	54	18	8	8.3	75	6	25	12.5	2	Ø3	50.7	10	2.86	5
GBV03 - 100	74	18	8	8.3	100	8	25	12.5	2	Ø3	65.7	13	2.86	5
GBV03 - 125	104	18	8	8.3	125	10	25	12.5	2	Ø3	75.7	15	2.86	5
GBV03 - 150	124	18	8	8.3	150	12	25	12.5	2	Ø3	90.7	18	2.86	5
GBV03 - 175	144	18	8	8.3	175	14	25	12.5	2	Ø3	105.7	21	2.86	5
GBV03 - 200	164	18	8	8.3	200	16	25	12.5	2	Ø3	120.7	24	2.86	5
GBV03 - 225	184	18	8	8.3	225	18	25	12.5	2	Ø3	135.7	27	2.86	5
GBV03 - 250	204	18	8	8.3	250	20	25	12.5	2	Ø3	150.7	30	2.86	5
GBV03 - 275	224	18	8	8.3	275	22	25	12.5	2	Ø3	165.7	33	2.86	5
GBV03 - 300	244	18	8	8.3	300	24	25	12.5	2	Ø3	180.7	36	2.86	5
GBV04 - 80	54	22	11	10	80	4	40	20	2	Ø4	56.8	8	3.9	7
GBV04 - 120	92	22	11	10	120	6	40	20	2	Ø4	77.8	11	3.9	7
GBV04 - 160	130	22	11	10	160	8	40	20	2	Ø4	98.8	14	3.9	7
GBV04 - 200	154	22	11	10	200	10	40	20	2	Ø4	126.8	18	3.9	7
GBV04 - 240	192	22	11	10	240	12	40	20	2	Ø4	147.8	21	3.9	7
GBV04 - 280	230	22	11	10	280	14	40	20	2	Ø4	168.8	24	3.9	7
GBV04 - 320	254	22	11	10	320	16	40	20	2	Ø4	196.8	28	3.9	7
GBV04 - 360	292	22	11	10	360	18	40	20	2	Ø4	217.8	31	3.9	7
GBV04 - 400	330	22	11	10	400	20	40	20	2	Ø4	238.8	34	3.9	7
GBV04 - 440	354	22	11	10	440	22	40	20	2	Ø4	266.8	38	3.9	7
GBV04 - 480	392	22	11	10	480	24	40	20	2	Ø4	287.8	41	3.9	7

Model Number Explanation

GB V 03 - 50
Ball Rail Type Size Length

MATERIAL SPECIFICATION

Model number	Rail	Roller	Retainer
GBV	SUJ2		Phosphor Bronze (C5191)

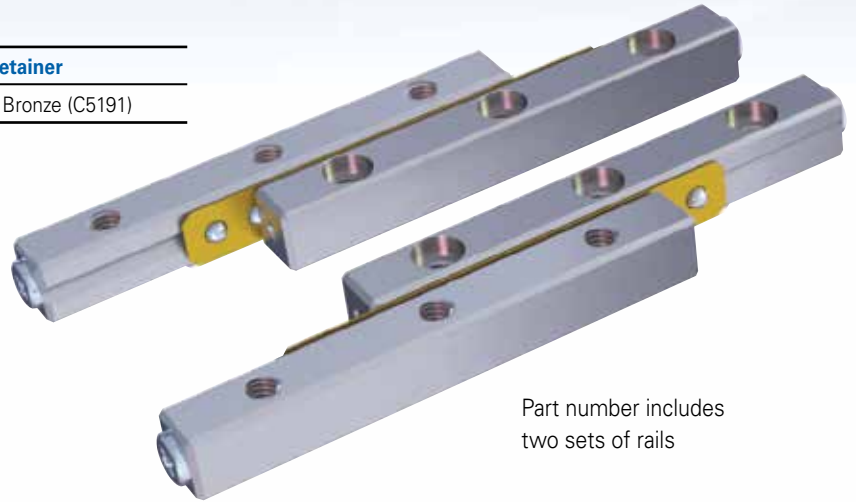

Part number includes two sets of rails

	MOUNTING DIMENSIONS (mm)					BASIC LOAD RATINGS PER BALL BEARING*		CAPACITY PER BALL BEARING* (N)	WEIGHT (g) / 2 PIECES Standard
	A	M	d ₁	d ₂	B	Dynamic C (N)	Static C ₀ (N)		
	3.5	M4	3.3	6	3.1	26.5	84	28	46
	3.5	M4	3.3	6	3.1	26.5	84	28	68
	3.5	M4	3.3	6	3.1	26.5	84	28	90
	3.5	M4	3.3	6	3.1	26.5	84	28	112
	3.5	M4	3.3	6	3.1	26.5	84	28	134
	3.5	M4	3.3	6	3.1	26.5	84	28	156
	3.5	M4	3.3	6	3.1	26.5	84	28	178
	3.5	M4	3.3	6	3.1	26.5	84	28	200
	3.5	M4	3.3	6	3.1	26.5	84	28	222
	3.5	M4	3.3	6	3.1	26.5	84	28	244
	3.5	M4	3.3	6	3.1	26.5	84	28	266
	4.5	M5	4.3	7.5	4.1	43	148	49.3	121
	4.5	M5	4.3	7.5	4.1	43	148	49.3	179
	4.5	M5	4.3	7.5	4.1	43	148	49.3	237
	4.5	M5	4.3	7.5	4.1	43	148	49.3	295
	4.5	M5	4.3	7.5	4.1	43	148	49.3	353
	4.5	M5	4.3	7.5	4.1	43	148	49.3	411
	4.5	M5	4.3	7.5	4.1	43	148	49.3	470
	4.5	M5	4.3	7.5	4.1	43	148	49.3	528
	4.5	M5	4.3	7.5	4.1	43	148	49.3	586
	4.5	M5	4.3	7.5	4.1	43	148	49.3	645
	4.5	M5	4.3	7.5	4.1	43	148	49.3	703

* For calculating cross ball rail load rating, see page 114.

GBV BALL SIZE 06 - 09 - 12
RAIL LENGTH 100 THRU 600

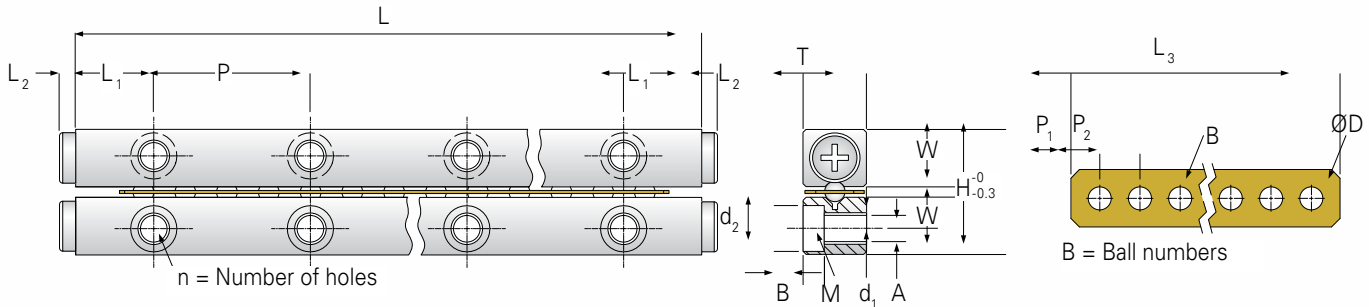

Model	Max. Stroke (mm)	MAIN DIMENSIONS (mm)								RETAINER DIMENSIONS (mm)				
		H	T	W	L	n	P	L ₁	L ₂	ØD	L ₃	B	P ₁	P ₂
GBV06 - 100	80	31	15	14	100	4	50	25	2	Ø6	63.6	7	4.8	9
GBV06 - 150	108	31	15	14	150	6	50	25	2	Ø6	99.6	11	4.8	9
GBV06 - 200	154	31	15	14	200	8	50	25	2	Ø6	126.6	14	4.8	9
GBV06 - 250	200	31	15	14	250	10	50	25	2	Ø6	153.6	17	4.8	9
GBV06 - 300	246	31	15	14	300	12	50	25	2	Ø6	180.6	20	4.8	9
GBV06 - 350	274	31	15	14	350	14	50	25	2	Ø6	216.6	24	4.8	9
GBV06 - 400	320	31	15	14	400	16	50	25	2	Ø6	243.6	27	4.8	9
GBV06 - 500	412	31	15	14	500	20	50	25	2	Ø6	297.6	33	4.8	9
GBV06 - 550	458	31	15	14	550	22	50	25	2	Ø6	324.6	36	4.8	9
GBV06 - 600	486	31	15	14	600	24	50	25	2	Ø6	360.6	40	4.8	9
GBV09 - 200	158	44	22	20.2	200	4	100	50	3.5	Ø9	129	90	8.5	14
GBV09 - 300	246	44	22	20.2	300	6	100	50	3.5	Ø9	185	12	8.5	14
GBV09 - 400	306	44	22	20.2	400	8	100	50	3.5	Ø9	255	18	8.5	14
GBV09 - 500	394	44	22	20.2	500	10	100	50	3.5	Ø9	311	22	8.5	14
GBV09 - 600	482	44	22	20.2	600	12	100	50	3.5	Ø9	367	26	8.5	14
GBV12 - 200	136	58	28	26.9	200	4	100	50	3.5	Ø12	145	7	12.5	20
GBV12 - 300	216	58	28	26.9	300	6	100	50	3.5	Ø12	205	10	12.5	20
GBV12 - 400	296	58	28	26.9	400	8	100	50	3.5	Ø12	265	13	12.5	20
GBV12 - 500	416	58	28	26.9	500	10	100	50	3.5	Ø12	305	15	12.5	20
GBV12 - 600	496	58	28	26.9	600	12	100	50	3.5	Ø12	365	18	12.5	20

Model Number Explanation

GB V 06 - 100
Ball Rail Type Size Length

LINEAR GUIDANCE

CROSS BALL RAIL

MATERIAL SPECIFICATION

Model number	Rail	Roller	Retainer
GBV	SUJ2		Phosphor Bronze (C5191)

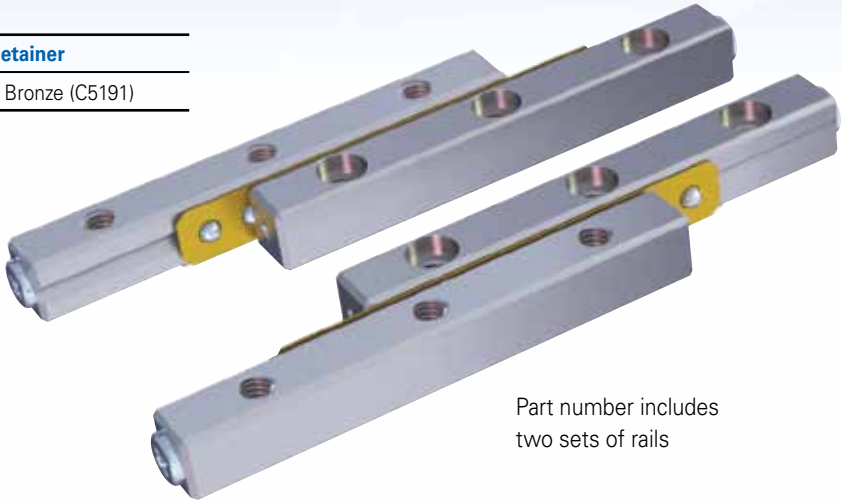

Part number includes two sets of rails

	MOUNTING DIMENSIONS (mm)					BASIC LOAD RATINGS PER BALL BEARING*		CAPACITY PER BALL BEARING*	WEIGHT (g) / 2 PIECES
	A	M	d ₁	d ₂	b	Dynamic C (N)	Static C ₀ (N)	(N)	Standard
	6	M6	5.3	9.5	5.2	92	330	110	287
	6	M6	5.3	9.5	5.2	92	330	110	429
	6	M6	5.3	9.5	5.2	92	330	110	571
	6	M6	5.3	9.5	5.2	92	330	110	712
	6	M6	5.3	9.5	5.2	92	330	110	852
	6	M6	5.3	9.5	5.2	92	330	110	993
	6	M6	5.3	9.5	5.2	92	330	110	1,135
	6	M6	5.3	9.5	5.2	92	330	110	1,275
	6	M6	5.3	9.5	5.2	92	330	110	1,417
	6	M6	5.3	9.5	5.2	92	330	110	1,558
	6	M6	5.3	9.5	5.2	92	330	110	1,250
	9	M8	6.8	10.5	6.2	207	750	250	1,254
	9	M8	6.8	10.5	6.2	207	750	250	1,871
	9	M8	6.8	10.5	6.2	207	750	250	2,484
	9	M8	6.8	10.5	6.2	207	750	250	3,101
	9	M8	6.8	10.5	6.2	207	750	250	3,718
	12	M10	8.5	13.5	8.2	300	1320	440	2,089
	12	M10	8.5	13.5	8.2	300	1320	440	3,122
	12	M10	8.5	13.5	8.2	300	1320	440	4,145
	12	M10	8.5	13.5	8.2	300	1320	440	5,178
	12	M10	8.5	13.5	8.2	300	1320	440	6,201

* For calculating cross ball rail load rating, see page 114.

CROSS BALL RAILS

CROSS ROLLER ASSEMBLY INTRODUCTION

ASSEMBLY

GRA 30 - 65 - N

MOUNTING

Bottom Mount GRA, GRS, GRC
Top Mount GRM, GRB, GRH

TABLE WIDTH

TABLE LENGTH

TABLE MATERIAL

N = S50C + Ni



COMPONENT MATERIAL SPECIFICATION

APPLY TO	MODEL NUMBER	MATERIAL INDICATION			
		Table	Rail	Retainer	Roller
Standard	GRA / GRB / GRC	Aluminum + anodizing black	SUJ2	SUS304	SUJ2
	GRS / GRH / GRM				
Nickel-plated	GRA - N / GRM - N	S50C + Ni	SUJ2 + Ni	SUS304	SUJ2
	GRB - N / GRH - N		V - groove in rail		
	GRC - N / GRS - N		no surface finished		



LINEAR GUIDANCE CROSS ROLLER ASSEMBLIES



CROSS ROLLER ASSEMBLIES

Nook Cross Roller Assemblies are composed of a matched pair of Nook Cross Roller Rails to provide highest accuracy and smooth movement.

SELECTION

1. Select unit width and length
2. Select model per installation
3. Acquire model no. from catalogs
4. Select standard, stainless or corrosion-resisting per environment request

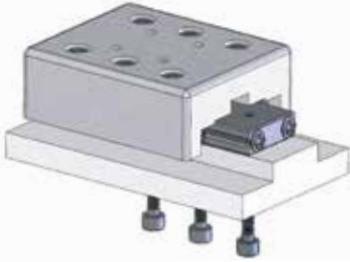
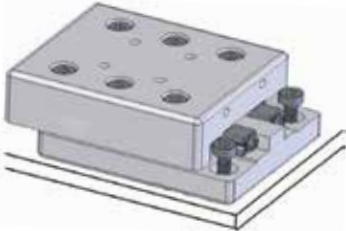
INSTALLATION SELECTION

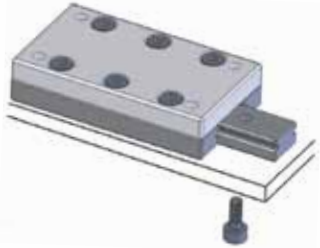
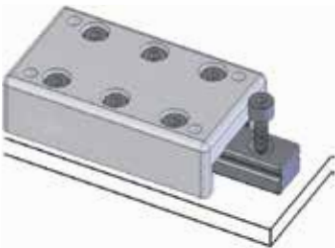
	Bottom Mount	Top Mount	
GRA		GRM	
GRS		GRB	
GRC		GRH	

CROSS ROLLER ASSEMBLIES

CROSS ROLLER ASSEMBLY INTRODUCTION

ACCURACY

High accuracy

Cross Roller Assemblies are ground to tight tolerance for the highest accuracy possible.

Low friction

The rollers provide low friction and stable performance in either low speed or high speed applications.

High rigidity Compact Size

Cross Roller Assemblies use the Cross Roller Rails providing the height rigidly and load capacity when compared to other linear products.

Table length	TABLE ACCURACY INSPECTION LEVEL		RAIL ACCURACY INSPECTION LEVEL
	Mid-delivery amplitude	Side-delivery amplitude	Straightness
0 ~ 50	0.002	0.004	0.002
50 ~ 100	0.002	0.005	0.002
100 ~ 150	0.003	0.006	0.003
150 ~ 200	0.003	0.007	0.003
200 ~ 250	0.003	0.007	0.003
250 ~ 300	0.003	0.007	0.003
300 ~ 350	0.004	0.008	0.004
350 ~ 400	0.004	0.008	0.004
400 ~ 450	0.004	0.008	0.004
450 ~ 500	0.004	0.008	0.004
500 ~ 550	0.004	0.009	0.004
550 ~ 600	0.004	0.009	0.004

Unit = mm

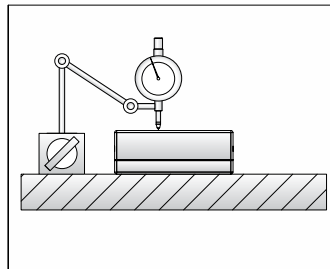
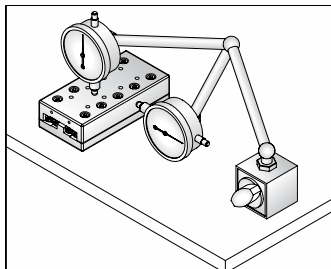

RATED LIFE CALCULATION OF TABLE AND PARAMETER CALCULATION FORMULA

$$L = \left(\frac{f_r}{f_w} \times \frac{C}{P_c} \right)^{10/3} \times 100$$

Where:

L = Rated life (km)

C = Basic dynamic load (kN)

P_c = Radial load calculated value (kN)

f_r = Temperature factor

f_w = Load factor

WORKING LIFE HOURS (L_h)

After calculating rated life (L), use formula below to calculate working life hours, if stroke length and travel times per minute are constant.

$$L_h = \frac{L \times 10^6}{2 \times l_s \times n_1 \times 60}$$

Where:

L_h = Working life hours (h)

l_s = Stroke length (mm)

n₁ = Travel times per minute (min⁻¹)

f_r = Temperature factor

Assemblies in an environment over 100°C should be run using high temperature lubricant. Calculate basic rated load × temperature factor as shown below.

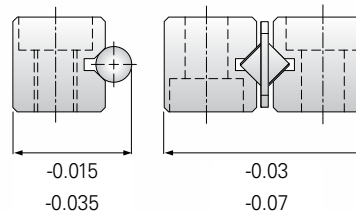
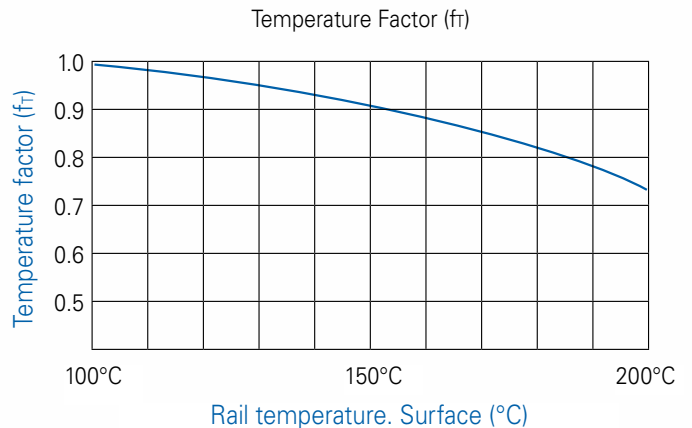

f_w = Load Factor

Applications with excessive deceleration or hard stops can cause permanent deformation of the v-guide rails. Use the chart below to consider proper load factor.

LOAD FACTOR (f_w)

Vibration / shock	Speed (V)	f_w
Tiny	Dead slow $V \leq 0.25$ m/s	1-1.2
Small	Slow $0.25 < V \leq 1$ m/s	1.2 - 1.5

TORQUE CALCULATION

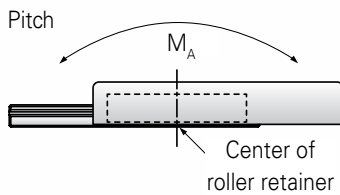

ROLLER QUANTITY = R

Roller

$$M_A = \frac{1}{2} \times \left(\frac{R}{2}\right)^2 C_0 \times P$$

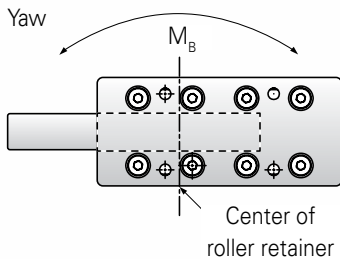

Roller

$$M_B = \frac{1}{2} \times (R^2 - R) C_0 \times P$$

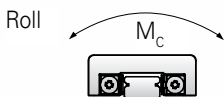

SINGLE STATIC LOAD RATING TYPE SELECTION

Roller

$$M_C = \frac{R}{2} \times C_0 \times L_R$$

Sf = Safety factor

OPERATION INSTRUCTIONS

Please operate carefully

Excessive deformation due to hard stops or crashes may cause permanent damage to the roller guides resulting in non-smooth movement.

Contamination

Dust and impurities mixed with components inside linear motion table may cause a decrease in accuracy or reduced life. Set outer dust cover to protect table when used in harsh environment.

Lubrication

All linear motion applications require proper lubrication. Abrasion and lack of lubrication will reduce life by 90%.

Function of lubrication:

1. Reduce friction between running parts.
2. Forming oil film on rolling surface to reduce abrasion of metal medium to extend life of rolling elements.
3. Covering on metal surface to prevent rust.

Deviation of roller retainer

Nook linear motion tables running in high speed, off-center load or vibration conditions, may cause retainer bending. Normal recommended speeds are below 30m/min. In addition, it is suggested that to minimize bending of the roller retainer, the assembly should be cycled full stroke to center the roller retainer while running.

Preload adjustment

Nook linear motion tables are factory set. No preload adjustment required.

GRA / GRA-N (NICKEL-PLATED) TYPE A - BOTTOM MOUNT
TABLE WIDTHS 30 - 40 - 60
TABLE LENGTH 25 THRU 205

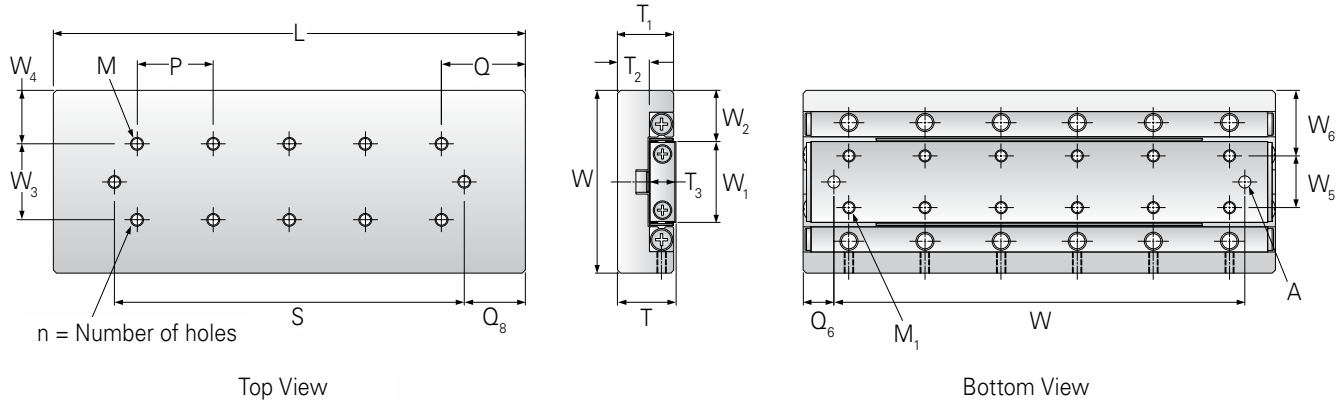

Model		Max. Stroke (mm)	Roller Dia. (mm)	MAIN DIMENSIONS (mm)			TABLE DIMENSIONS (mm)									
Standard	Nickel-plated			W	T	L	W ₃	W ₄	Q	Q ₈	n	P	M	S	T ₁	T ₂
GRA30 - 25	GRA30 - 25 - N	12	Ø 1.5	30 ±0.1	11 ±0.1	25	10	10	12.5	2.5	2	—	M2	20	11	4
GRA30 - 35	GRA30 - 35 - N	18	Ø 1.5	30 ±0.1	11 ±0.1	35	10	10	12.5	4.5	4	10	M2	26	11	4
GRA30 - 45	GRA30 - 45 - N	25	Ø 1.5	30 ±0.1	11 ±0.1	45	10	10	12.5	6	6	10	M2	33	11	4
GRA30 - 55	GRA30 - 55 - N	32	Ø 1.5	30 ±0.1	11 ±0.1	55	10	10	12.5	7.5	8	10	M2	40	11	4
GRA30 - 65	GRA30 - 65 - N	40	Ø 1.5	30 ±0.1	11 ±0.1	65	10	10	12.5	8.5	10	10	M2	48	11	4
GRA30 - 75	GRA30 - 75 - N	45	Ø 1.5	30 ±0.1	11 ±0.1	75	10	10	12.5	11	12	10	M2	53	11	4
GRA30 - 85	GRA30 - 85 - N	50	Ø 1.5	30 ±0.1	11 ±0.1	85	10	10	12.5	13.5	14	10	M2	58	11	4
GRA40 - 35	GRA40 - 35 - N	18	Ø 2.0	40 ±0.1	14 ±0.1	35	15	12.5	17.5	3	2	—	M3	29	14	8
GRA40 - 50	GRA40 - 50 - N	30	Ø 3.0	40 ±0.1	15 ±0.1	50	15	12.5	17.5	4.5	4	15	M3	41	15	7
GRA40 - 65	GRA40 - 65 - N	40	Ø 3.0	40 ±0.1	15 ±0.1	65	15	12.5	17.5	7	6	15	M3	51	15	7
GRA40 - 80	GRA40 - 80 - N	50	Ø 3.0	40 ±0.1	15 ±0.1	80	15	12.5	17.5	9.5	8	15	M3	61	15	7
GRA40 - 95	GRA40 - 95 - N	60	Ø 3.0	40 ±0.1	15 ±0.1	95	15	12.5	17.5	12	10	15	M3	71	15	7
GRA40 - 110	GRA40 - 110 - N	70	Ø 3.0	40 ±0.1	15 ±0.1	110	15	12.5	17.5	14.5	12	15	M3	81	15	7
GRA40 - 125	GRA40 - 125 - N	80	Ø 3.0	40 ±0.1	15 ±0.1	125	15	12.5	17.5	17	14	15	M3	91	15	7
GRA60 - 55	GRA60 - 55 - N	30	Ø 3.0	60 ±0.1	18.5 ±0.1	55	25	17.5	27.5	5.5	2	—	M4	44	18.5	10.5
GRA60 - 80	GRA60 - 80 - N	45	Ø 3.0	60 ±0.1	18.5 ±0.1	80	25	17.5	27.5	10.5	4	25	M4	59	18.5	10.5
GRA60 - 105	GRA60 - 105 - N	60	Ø 3.0	60 ±0.1	18.5 ±0.1	105	25	17.5	27.5	15.5	6	25	M4	74	18.5	10.5
GRA60 - 130	GRA60 - 130 - N	75	Ø 3.0	60 ±0.1	18.5 ±0.1	130	25	17.5	27.5	20.5	8	25	M4	89	18.5	10.5
GRA60 - 155	GRA60 - 155 - N	90	Ø 3.0	60 ±0.1	18.5 ±0.1	155	25	17.5	27.5	25.5	10	25	M4	104	18.5	10.5
GRA60 - 180	GRA60 - 180 - N	105	Ø 3.0	60 ±0.1	18.5 ±0.1	180	25	17.5	27.5	30.5	12	25	M4	119	18.5	10.5
GRA60 - 205	GRA60 - 205 - N	130	Ø 3.0	60 ±0.1	18.5 ±0.1	205	25	17.5	27.5	30.5	14	25	M4	144	18.5	10.5

Model Number Explanation

GR A 30 - 25 - N
 Roller Mounting Type Width Length Nickel-plated

MATERIAL SPECIFICATION

Model number	Table	Rail	Retainer	Roller
GRA	Aluminum alloy + black anodized	SUJ2	SUS304	SUJ2
GRA-N	S50C + Ni	SUJ2 + Ni	SUS304	SUJ2

GRA-N no precision ground finish to V - groove surface of the rail.



BASE MOUNTING DIMENSIONS (mm)										BASIC LOAD RATING (N)		STATIC RATED MOMENT (N·m)			CAPACITY PER ROLLER BEARING* (N)	WEIGHT (kg)		LINEAR ACCURACY (μm)	
T ₃	W ₁	W ₂	W ₅	W ₈	Q ₂	L ₆	M ₁	A	Dynamic C	Static C ₀	M _A	M _B	M _C	Standard		Nickel-plated	Parallelism Center	Parallelism Side	
4	12.8	8.6	—	15	—	—	M2	—	379	576	1.2	1.4	2.6	192	0.03	0.05	2	4	
4	12.8	8.6	—	15	—	—	M2	—	523	865	2.6	3.0	3.9	288	0.04	0.08	2	4	
4	12.8	8.6	—	15	—	—	M2	—	657	1,153	4.6	5.2	5.2	384	0.05	0.10	2	4	
4	12.8	8.6	—	15	12.5	30	M2	2	783	1,441	7.2	7.9	6.5	480	0.06	0.12	2	5	
4	12.8	8.6	—	15	12.5	40	M2	2	903	1,729	10.4	11.2	7.8	576	0.07	0.15	2	5	
4	12.8	8.6	—	15	12.5	50	M2	2	1,131	2,306	18.4	17.3	10.4	769	0.09	0.17	2	5	
4	12.8	8.6	—	15	12.5	60	M2	2	1,240	2,594	23.3	22.0	11.7	865	0.10	0.19	2	5	
6	17	11.5	—	20	—	—	M3	—	895	1,170	3.1	3.9	7.0	390	0.07	0.13	2	4	
8	13.1	13.5	—	20	—	—	M3	—	2,901	4,567	22.8	26.6	42.6	1,522	0.13	0.21	2	4	
8	13.1	13.5	—	20	—	—	M3	—	2,901	4,567	22.8	19.0	42.6	1,522	0.14	0.25	2	5	
8	13.1	13.5	—	20	17.5	45	M3	3	4,338	7,611	63.4	57.1	71.0	2,537	0.20	0.33	2	5	
8	13.1	13.5	—	20	25	45	M3	3	3,640	6,089	40.6	45.7	56.8	2,030	0.21	0.36	2	5	
8	13.1	13.5	—	20	25	60	M3	3	5,005	9,133	91.3	98.9	85.2	3,044	0.27	0.45	3	6	
8	13.1	13.5	—	20	32.5	60	M3	3	5,005	9,133	91.3	83.7	85.2	3,044	0.28	0.48	3	6	
8	26.6	16.7	25	21.5	10	35	M4	4	2,901	4,567	22.8	26.6	42.3	1,522	0.23	0.43	2	5	
8	26.6	16.7	25	21.5	10	60	M4	4	4,338	7,611	63.4	57.1	71.0	2,537	0.34	0.62	2	5	
8	26.6	16.7	25	21.5	10	85	M4	4	5,646	10,655	124.3	115.4	99.5	3,552	0.45	0.82	3	6	
8	26.6	16.7	25	21.5	10	110	M4	4	6,268	12,178	162.4	172.5	112.7	4,059	0.57	1.02	3	6	
8	26.6	16.7	25	21.5	10	135	M4	4	7,462	15,222	253.7	266.4	142.1	5,074	0.66	1.21	3	6	
8	26.6	16.7	25	21.5	10	160	M4	4	8,603	18,266	365.3	350.1	170.5	6,089	0.77	1.41	3	7	
8	26.6	16.7	25	21.5	10	185	M4	4	9,157	19,789	428.8	445.2	184.7	6,596	0.87	1.60	3	7	

* For calculating cross roller rail load rating, see page 114.

GRA / GRA-N (NICKEL-PLATED) TYPE A - BOTTOM MOUNT
TABLE WIDTHS 80 - 100 - 145
TABLE LENGTH 85 THRU 510

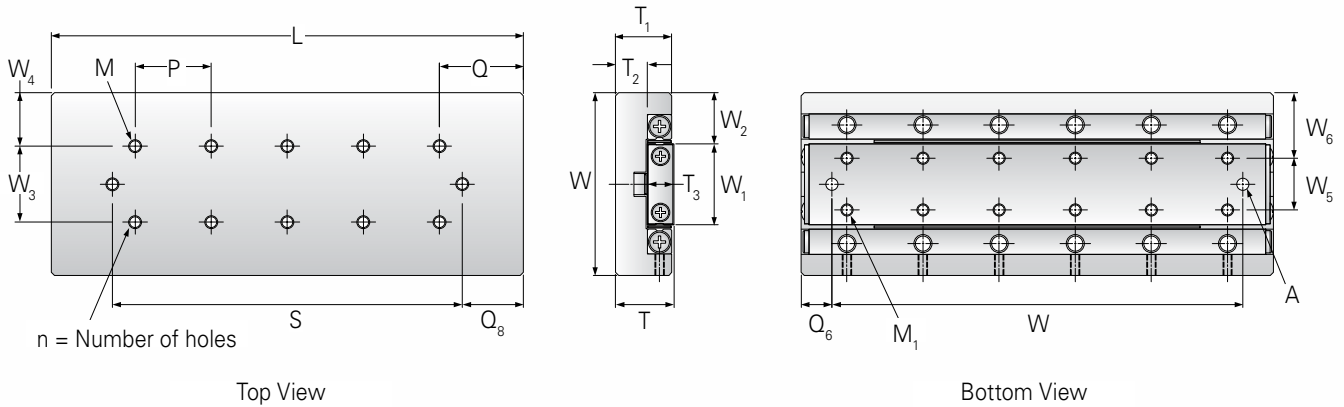

Model	Max. Stroke (mm)	Roller Dia. (mm)	MAIN DIMENSIONS (mm)			TABLE DIMENSIONS (mm)										
			W	T	L	W ₃	W ₄	Q	Q ₈	n	P	M	S	T ₁	T ₂	
Standard	Nickel-plated															
GRA80 - 85	GRA80 - 85 - N	50	Ø 4.0	80 ±0.1	24 ±0.1	85	40	20	42.5	10.5	2	—	M5	64	24	13
GRA80 - 125	GRA80 - 125 - N	75	Ø 4.0	80 ±0.1	24 ±0.1	125	40	20	42.5	18	4	40	M5	89	24	13
GRA80 - 165	GRA80 - 165 - N	105	Ø 4.0	80 ±0.1	24 ±0.1	165	40	20	42.5	23	6	40	M5	119	24	13
GRA80 - 205	GRA80 - 205 - N	135	Ø 4.0	80 ±0.1	24 ±0.1	205	40	20	42.5	28	8	40	M5	149	24	13
GRA80 - 245	GRA80 - 245 - N	155	Ø 4.0	80 ±0.1	24 ±0.1	245	40	20	42.5	38	10	40	M5	169	24	13
GRA80 - 285	GRA80 - 285 - N	185	Ø 4.0	80 ±0.1	24 ±0.1	285	40	20	42.5	43	12	40	M5	199	24	13
GRA80 - 325	GRA80 - 325 - N	215	Ø 4.0	80 ±0.1	24 ±0.1	325	40	20	42.5	48	14	40	M5	229	24	13
GRA100 - 110	GRA100 - 110 - N	60	Ø 6.0	100 ±0.1	31 ±0.1	110	50	25	55	16.5	2	—	M6	77	31	16
GRA100 - 160	GRA100 - 160 - N	95	Ø 6.0	100 ±0.1	31 ±0.1	160	50	25	55	23.5	4	50	M6	113	31	16
GRA100 - 210	GRA100 - 210 - N	130	Ø 6.0	100 ±0.1	31 ±0.1	210	50	25	55	31	6	50	M6	148	31	16
GRA100 - 260	GRA100 - 260 - N	165	Ø 6.0	100 ±0.1	31 ±0.1	260	50	25	55	38.5	8	50	M6	183	31	16
GRA100 - 310	GRA100 - 310 - N	200	Ø 6.0	100 ±0.1	31 ±0.1	310	50	25	55	46	10	50	M6	218	31	16
GRA100 - 360	GRA100 - 360 - N	235	Ø 6.0	100 ±0.1	31 ±0.1	360	50	25	55	53.5	12	50	M6	253	31	16
GRA100 - 410	GRA100 - 410 - N	265	Ø 6.0	100 ±0.1	31 ±0.1	410	50	25	55	63.5	14	50	M6	283	31	16
GRA145 - 210	GRA145 - 210 - N	130	Ø 9.0	145 ±0.1	42.5 ±0.1	210	85	30	105	27	2	—	M8	156	43	21
GRA145 - 310	GRA145 - 310 - N	180	Ø 9.0	145 ±0.1	42.5 ±0.1	310	85	30	105	52	4	100	M8	206	43	21
GRA145 - 410	GRA145 - 410 - N	350	Ø 9.0	145 ±0.1	42.5 ±0.1	410	85	30	105	17	6	100	M8	376	43	21
GRA145 - 510	GRA145 - 510 - N	450	Ø 9.0	145 ±0.1	42.5 ±0.1	510	85	30	105	17	8	100	M8	476	43	21

Model Number Explanation

GR A 80 - 85 - N
 Roller Mounting Type Width Length Nickel-plated

MATERIAL SPECIFICATION

Model number	Table	Rail	Retainer	Roller
GRA	Aluminum alloy + black anodized	SUJ2	SUS304	SUJ2
GRA-N	S50C + Ni	SUJ2 + Ni	SUS304	SUJ2

GRA-N no precision ground finish to V - groove surface of the rail.



BASE MOUNTING DIMENSIONS (mm)										BASIC LOAD RATING (N)		STATIC RATED MOMENT (N-m)			CAPACITY PER ROLLER BEARING* (N)	WEIGHT (kg)		LINEAR ACCURACY (μm)	
T ₃	W ₁	W ₂	W ₅	Q ₁	Q ₂	L ₆	M ₁	A	Dynamic C	Static C ₀	M _A	M _B	M _C	Standard		Nickel-plated	Center	Side	
11	38	21	27	22.5	15	55	M5	5 ^{+0.2} ₀	6,617	9,357	87.3	76.4	124.8	3,119	0.64	1.17	2	5	
11	38	21	27	22.5	15	95	M5	5 ^{+0.2} ₀	9,097	14,035	196.5	180.1	187.1	4,678	0.95	1.72	3	6	
11	38	21	27	22.5	15	135	M5	5 ^{+0.2} ₀	10,264	16,375	267.5	286.6	218.3	5,458	1.25	2.27	3	7	
11	38	21	27	22.5	15	175	M5	5 ^{+0.2} ₀	12,496	21,053	442.1	466.7	280.7	7,018	1.56	2.83	3	7	
11	38	21	27	22.5	15	215	M5	5 ^{+0.2} ₀	14,612	25,732	660.4	690.5	343.1	8,577	1.87	3.39	3	7	
11	38	21	27	22.5	15	255	M5	5 ^{+0.2} ₀	16,646	30,410	922.4	957.9	405.5	10,137	2.18	3.94	3	7	
11	38	21	27	22.5	15	295	M5	5 ^{+0.2} ₀	18,612	35,089	1228.1	1,187.2	467.8	11,696	2.49	4.50	4	8	
15	42	29	26	30	20	70	M6	5 ^{+0.2} ₀	13,923	21,053	2,525.6	221.1	315.8	7,018	1.31	2.39	3	6	
15	42	29	26	30	20	120	M6	5 ^{+0.2} ₀	16,592	26,316	394.7	434.2	394.7	8,772	1.93	3.50	3	6	
15	42	29	26	30	20	170	M6	5 ^{+0.2} ₀	21,592	36,842	773.7	828.9	552.6	12,281	2.56	4.61	3	7	
15	42	29	26	30	20	220	M6	5 ^{+0.2} ₀	26,285	47,369	1,279.0	1,207.9	710.5	15,790	3.16	5.70	3	7	
15	42	29	26	30	20	270	M6	5 ^{+0.2} ₀	30,744	57,895	1,910.5	1,823.7	868.4	19,298	3.78	6.81	3	7	
15	42	29	26	30	20	320	M6	5 ^{+0.2} ₀	35,024	68,421	2,668.4	2,565.8	1,026.3	22,807	4.41	7.93	4	8	
15	42	29	26	30	20	370	M6	5 ^{+0.2} ₀	39,160	78,948	3,552.6	3,434.2	1,184.2	26,316	5.03	9.04	4	8	
21	68.4	38.3	46	55	30	150	M8	5 ^{+0.2} ₀	46,991	72,741	1,697.3	1,527.6	1,745.8	24,247	5.35	9.30	3	7	
21	68.4	38.3	46	55	30	250	M8	5 ^{+0.2} ₀	61,165	101,838	3,326.7	3,564.3	2,444.1	33,946	7.96	13.79	3	7	
21	68.4	38.3	46	55	30	350	M8	5 ^{+0.2} ₀	67,898	116,386	4,345.1	4,073.5	2,793.3	38,795	10.47	18.18	4	8	
21	68.4	38.3	46	55	30	450	M8	5 ^{+0.2} ₀	80,829	145,482	6,789.2	6,449.7	3,491.6	48,494	13.06	22.66	4	8	

* For calculating cross roller rail load rating, see page 114.

GRB / GRB-N (NICKEL-PLATED) TYPE B - TOP MOUNT
TABLE WIDTHS 30 - 40 - 60
TABLE LENGTH 25 THRU 205

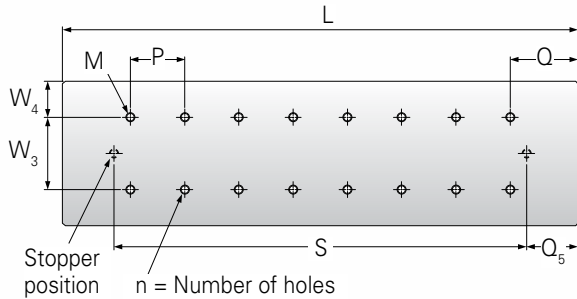

Top View

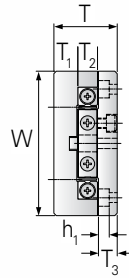

Typical both ends

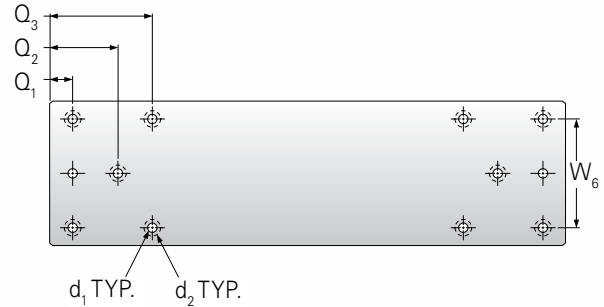

Bottom View

Model		Max. Stroke (mm)	Roller Dia. (mm)	MAIN DIMENSIONS (mm)						TABLE DIMENSIONS (mm)						
Standard	Nickel-plated			W	T	L	T ₁	T ₂	T ₃	n	P	M	S	Q	W ₃	W ₄
GRB30 - 25	GRB30 - 25 - N	12	∅ 1.5	30 ±0.1	17 ±0.1	25	7	4	5.5	2	—	M2	20	12.5	10	10
GRB30 - 35	GRB30 - 35 - N	18	∅ 1.5	30 ±0.1	17 ±0.1	35	7	4	5.5	4	10	M2	26	12.5	10	10
GRB30 - 45	GRB30 - 45 - N	25	∅ 1.5	30 ±0.1	17 ±0.1	45	7	4	5.5	6	10	M2	33	12.5	10	10
GRB30 - 55	GRB30 - 55 - N	32	∅ 1.5	30 ±0.1	17 ±0.1	55	7	4	5.5	8	10	M2	40	12.5	10	10
GRB30 - 65	GRB30 - 65 - N	40	∅ 1.5	30 ±0.1	17 ±0.1	65	7	4	5.5	10	10	M2	48	12.5	10	10
GRB30 - 75	GRB30 - 75 - N	45	∅ 1.5	30 ±0.1	17 ±0.1	75	7	4	5.5	12	10	M2	53	12.5	10	10
GRB30 - 85	GRB30 - 85 - N	50	∅ 1.5	30 ±0.1	17 ±0.1	85	7	4	5.5	14	10	M2	58	12.5	10	10
GRB40 - 35	GRB40 - 35 - N	18	∅ 2.0	40 ±0.1	21 ±0.1	35	8	6	6.5	2	—	M3	29	17.5	15	12.5
GRB40 - 50	GRB40 - 50 - N	30	∅ 3.0	40 ±0.1	21 ±0.1	50	7	8	5.5	4	15	M3	41	17.5	15	12.5
GRB40 - 65	GRB40 - 65 - N	40	∅ 3.0	40 ±0.1	21 ±0.1	65	7	8	5.5	6	15	M3	51	17.5	15	12.5
GRB40 - 80	GRB40 - 80 - N	50	∅ 3.0	40 ±0.1	21 ±0.1	80	7	8	5.5	8	15	M3	61	17.5	15	12.5
GRB40 - 95	GRB40 - 95 - N	60	∅ 3.0	40 ±0.1	21 ±0.1	95	7	8	5.5	10	15	M3	71	17.5	15	12.5
GRB40 - 110	GRB40 - 110 - N	70	∅ 3.0	40 ±0.1	21 ±0.1	110	7	8	5.5	12	15	M3	81	17.5	15	12.5
GRB40 - 125	GRB40 - 125 - N	80	∅ 3.0	40 ±0.1	21 ±0.1	125	7	8	5.5	14	15	M3	91	17.5	15	12.5
GRB60 - 55	GRB60 - 55 - N	30	∅ 3.0	60 ±0.1	28 ±0.1	55	10.5	8	9	2	—	M4	44	27.5	25	17.5
GRB60 - 80	GRB60 - 80 - N	45	∅ 3.0	60 ±0.1	28 ±0.1	80	10.5	8	9	4	25	M4	59	27.5	25	17.5
GRB60 - 105	GRB60 - 105 - N	60	∅ 3.0	60 ±0.1	28 ±0.1	105	10.5	8	9	6	25	M4	74	27.5	25	17.5
GRB60 - 130	GRB60 - 130 - N	75	∅ 3.0	60 ±0.1	28 ±0.1	130	10.5	8	9	8	25	M4	89	27.5	25	17.5
GRB60 - 155	GRB60 - 155 - N	90	∅ 3.0	60 ±0.1	28 ±0.1	155	10.5	8	9	10	25	M4	104	27.5	25	17.5
GRB60 - 180	GRB60 - 180 - N	105	∅ 3.0	60 ±0.1	28 ±0.1	180	10.5	8	9	12	25	M4	119	27.5	25	17.5
GRB60 - 205	GRB60 - 205 - N	130	∅ 3.0	60 ±0.1	28 ±0.1	205	10.5	8	9	14	25	M4	144	27.5	25	17.5

Model Number Explanation

GR B 30 - 25 - N
 Roller Mounting Type Width Length Nickel-plated

MATERIAL SPECIFICATION

Model number	Table	Rail	Retainer	Roller
GRB	Aluminum alloy + black anodized	SUJ2	SUS304	SUJ2
GRB-N	S50C + Ni	SUJ2 + Ni	SUS304	SUJ2

GRB-N no precision ground finish to V - groove surface of the rail.



GRB



GRB-N

Q ₁	Q ₂	Q ₃	W ₆	d ₁	d ₂	h ₁	h ₂	BASIC LOAD RATING (N)		STATIC RATED MOMENT (N·m)			CAPACITY PER ROLLER BEARING* (N)	WEIGHT (kg)		LINEAR ACCURACY (μm)	
								Dynamic	Static	M _A	M _B	M _C		Standard	Nickel-plated	Center	Side
3.5	—	—	4	2.55	4.1	2.5	6	379	576	1.2	1.4	2.6	192	0.04	0.09	2	4
3.5	—	—	4	2.55	4.1	2.5	6	523	865	2.6	3.0	3.9	288	0.06	0.12	2	4
3.5	—	—	4	2.55	4.1	2.5	6	657	1,153	4.6	5.2	5.2	384	0.07	0.16	2	4
3.5	—	13.5	4	2.55	4.1	2.5	6	783	1,441	7.2	7.9	6.5	480	0.09	0.19	2	5
3.5	—	13.5	4	2.55	4.1	2.5	6	903	1,729	10.4	11.2	7.8	576	0.10	0.23	2	5
3.5	—	13.5	4	2.55	4.1	2.5	6	1,131	2,306	18.4	17.3	10.4	769	0.12	0.27	2	5
3.5	—	13.5	4	2.55	4.1	2.5	6	1,240	2,594	23.3	22.0	11.7	865	0.14	0.30	2	5
5	—	—	5	3.5	6	3.5	7	895	1,170	3.1	3.9	7.0	390	0.10	0.20	2	4
5	—	—	5	3.5	6	3.2	6	2,901	4,567	22.8	26.6	42.6	1,522	0.16	0.29	2	4
5	—	—	5	3.5	6	3.2	6	290	4,567	22.8	19.0	42.6	1,522	0.18	0.36	2	5
5	—	20	5	3.5	6	3.2	6	4,338	7,611	63.4	57.1	70.0	2,537	0.25	0.46	2	5
5	—	20	5	3.5	6	3.2	6	3,640	6,089	40.6	45.7	56.8	2,030	0.27	0.53	2	5
5	—	20	5	3.5	6	3.2	6	5,005	9,133	91.3	98.9	85.2	3,044	0.34	0.63	3	6
5	—	20	5	3.5	6	3.2	6	5,005	9,113	91.3	83.7	85.2	3,044	0.36	0.69	3	6
10	—	—	10	4.5	7.5	4.5	9.5	2,901	4,567	22.8	26.6	42.6	1,522	0.31	0.65	2	5
10	—	—	10	4.5	7.5	4.5	9.5	4,338	7,611	63.4	57.1	71.0	25,327	0.46	0.96	2	5
10	—	—	10	4.5	7.5	4.5	9.5	5,646	10,655	124.3	115.4	99.5	3,552	0.61	1.27	3	6
10	—	—	10	4.5	7.5	4.5	9.5	6,268	12,178	162.4	172.5	113.7	4,059	0.76	1.57	3	6
10	35	—	10	4.5	7.5	4.5	9.5	7,462	15,222	253.7	266.4	142.1	5,074	0.90	1.87	3	6
10	35	—	10	4.5	7.5	4.5	9.5	8,603	18,266	365.3	350.1	170.5	6,089	1.05	2.18	3	7
10	35	60	10	4.5	7.5	4.5	9.5	9,157	19,789	428.8	445.2	184.7	6,596	1.20	2.47	3	7

* For calculating cross roller rail load rating, see page 114.

GRB / GRB-N (NICKEL-PLATED) TYPE B - TOP MOUNT
TABLE WIDTHS 80 - 100 - 145
TABLE LENGTH 85 THRU 510

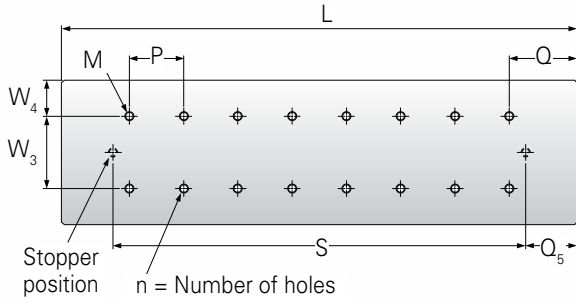

Top View

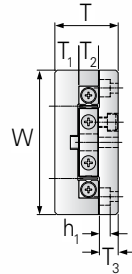

Typical both ends

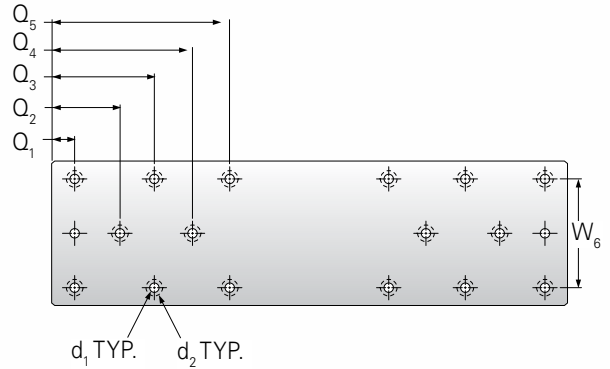

Bottom View

Model		Max. Stroke (mm)	Roller Dia. (mm)	MAIN DIMENSIONS (mm)						TABLE DIMENSIONS (mm)						
Standard	Nickel-plated			W	T	L	T ₁	T ₂	T ₃	n	P	M	S	Q	W ₃	W ₄
GRB80 - 85	GRB80 - 85 - N	50	Ø 4.0	80 ±0.1	35 ±0.1	85	13	11	10.5	2	—	M5	64	42.5	40	20
GRB80 - 125	GRB80 - 125 - N	75	Ø 4.0	80 ±0.1	35 ±0.1	125	13	11	10.5	4	40	M5	89	42.5	40	20
GRB80 - 165	GRB80 - 165 - N	105	Ø 4.0	80 ±0.1	35 ±0.1	165	13	11	10.5	6	40	M5	119	42.5	40	20
GRB80 - 205	GRB80 - 205 - N	135	Ø 4.0	80 ±0.1	35 ±0.1	205	13	11	10.5	8	40	M5	149	42.5	40	20
GRB80 - 245	GRB80 - 245 - N	155	Ø 4.0	80 ±0.1	35 ±0.1	245	13	11	10.5	10	40	M5	169	42.5	40	20
GRB80 - 285	GRB80 - 285 - N	185	Ø 4.0	80 ±0.1	35 ±0.1	285	13	11	10.5	12	40	M5	199	42.5	40	20
GRB80 - 325	GRB80 - 325 - N	215	Ø 4.0	80 ±0.1	35 ±0.1	325	13	11	10.5	14	40	M5	229	42.5	40	20
GRB100 - 110	GRB100 - 110 - N	60	Ø 6.0	100 ±0.1	45 ±0.1	110	16	15	13	2	50	M6	77	55	50	25
GRB100 - 160	GRB100 - 160 - N	95	Ø 6.0	100 ±0.1	45 ±0.1	160	16	15	13	4	50	M6	113	55	50	25
GRB100 - 210	GRB100 - 210 - N	130	Ø 6.0	100 ±0.1	45 ±0.1	210	16	15	13	6	50	M6	148	55	50	25
GRB100 - 260	GRB100 - 260 - N	165	Ø 6.0	100 ±0.1	45 ±0.1	260	16	15	13	8	50	M6	183	55	50	25
GRB100 - 310	GRB100 - 310 - N	200	Ø 6.0	100 ±0.1	45 ±0.1	310	16	15	13	10	50	M6	218	55	50	25
GRB100 - 360	GRB100 - 360 - N	235	Ø 6.0	100 ±0.1	45 ±0.1	360	16	15	13	12	50	M6	253	55	50	25
GRB100 - 410	GRB100 - 410 - N	265	Ø 6.0	100 ±0.1	45 ±0.1	410	16	15	13	14	50	M6	283	55	50	25
GRB145 - 210	GRB145 - 210 - N	130	Ø 9.0	145 ±0.1	60 ±0.1	210	21	22	16	2	100	M8	156	105	85	30
GRB145 - 310	GRB145 - 310 - N	180	Ø 9.0	145 ±0.1	60 ±0.1	310	21	22	16	4	100	M8	206	105	85	30
GRB145 - 410	GRB145 - 410 - N	350	Ø 9.0	145 ±0.1	60 ±0.1	410	21	22	16	6	100	M8	376	105	85	30
GRB145 - 510	GRB145 - 510 - N	450	Ø 9.0	145 ±0.1	60 ±0.1	510	21	22	16	8	100	M8	476	105	85	30

Model Number Explanation

GR B 80 - 85 - N
 Roller Mounting Type Width Length Nickel-plated

MATERIAL SPECIFICATION

Model number	Table	Rail	Retainer	Roller
GRB	Aluminum alloy + black anodized	SUJ2	SUS304	SUJ2
GRB-N	S50C + Ni	SUJ2 + Ni	SUS304	SUJ2

GRB-N no precision ground finish to V-groove surface of the rail.



BASE MOUNTING DIMENSIONS (mm)												BASIC LOAD RATING (N)		STATIC RATED MOMENT (N-m)			CAPACITY PER ROLLER BEARING* (N)	WEIGHT (kg)		LINEAR ACCURACY (μm)	
n ₁	P ₁	Q ₁	Q ₂	Q ₃	Q ₅	W ₆	d ₁	d ₂	h ₁	h ₂	Dynamic	Static	M _A	M _B	M _C	Standard		Nickel-plated	Center	Side	
2	—	22.5	—	—	—	10	5.5	9.5	6	11	6,617	9,357	87.3	76.4	124.8	3,119	.84	1.72	2	5	
4	40	22.5	—	—	—	10	5.5	9.5	6	11	9,097	14,035	196.5	180.1	187.1	4,678	1.25	2.55	3	6	
6	40	22.5	—	—	—	10	5.5	9.5	6	11	10,264	16,375	267.6	286.6	218.3	5,458	1.65	3.37	3	7	
8	40	22.5	—	62.5	—	10	5.5	9.5	6	11	12,492	21,053	442.1	466.7	280.7	7,018	2.06	4.18	3	7	
10	40	22.5	—	62.5	—	10	5.5	9.5	6	11	14,612	25,732	660.4	690.5	343.1	8,577	2.46	5	3	7	
12	40	22.5	—	62.5	—	10	5.5	9.5	6	11	16,646	30,410	622.4	957.9	405.5	10,137	2.87	5.83	3	7	
14	40	22.5	—	62.5	102.5	10	5.5	9.5	6	11	18,612	35,089	1,228.1	1,187.2	467.8	11,969	3.27	6.64	74	8	
2	50	10	—	—	—	20	7	11	6.5	14	13,923	21,053	252.6	221.1	315.8	7,018	1.27	3.51	3	6	
4	50	10	—	—	—	20	7	11	6.5	14	16,592	26,316	394.7	434.2	394.7	8,772	2.53	5.15	3	6	
6	50	10	60	—	—	20	7	11	6.5	14	21,596	36,842	773.7	828.9	552.6	12,281	3.34	6.79	3	7	
8	50	10	60	110	—	20	7	11	6.5	14	26,285	47,369	1,279.0	1,207.9	710.5	15,790	4.13	8.39	3	7	
10	50	10	60	110	—	20	7	11	6.5	14	30,744	57,895	1,910.5	1,823.7	868.4	19,298	4.95	10.04	3	7	
12	50	10	60	110	—	20	7	11	6.5	14	35,024	68,421	2,668.4	2,565.8	1,026.3	22,807	5.75	11.64	4	8	
14	50	10	60	110	—	20	7	11	6.5	14	39,160	78,948	3,552.6	3,434.2	1,184.2	26,316	6.56	13.28	4	8	
2	100	55	—	—	—	27.5	9	14	8.5	17.5	46,991	72,741	1697.3	1,527.6	1,745.8	24,247	6.75	13.23	3	7	
4	100	55	—	—	—	27.5	9	14	8.5	17.5	61,165	101,838	3,326.7	3,564.3	2,444.1	33,946	10.03	19.62	3	7	
6	100	55	155	—	—	27.5	9	14	8.5	17.5	67,898	116,386	4,345.1	4,073.5	2,793.3	38,795	13.21	25.88	4	8	
8	100	55	155	—	—	27.5	9	14	8.5	17.5	80,829	145,482	6,789.2	6,449.7	3,491.6	48,494	16.48	32.26	4	8	

* For calculating cross roller rail load rating, see page 114.

CROSS ROLLER ASSEMBLIES

GRC / GRC-N (NICKEL-PLATED) TYPE C - BOTTOM MOUNT
TABLE WIDTHS 20 - 30 - 40
TABLE LENGTH 25 THRU 155

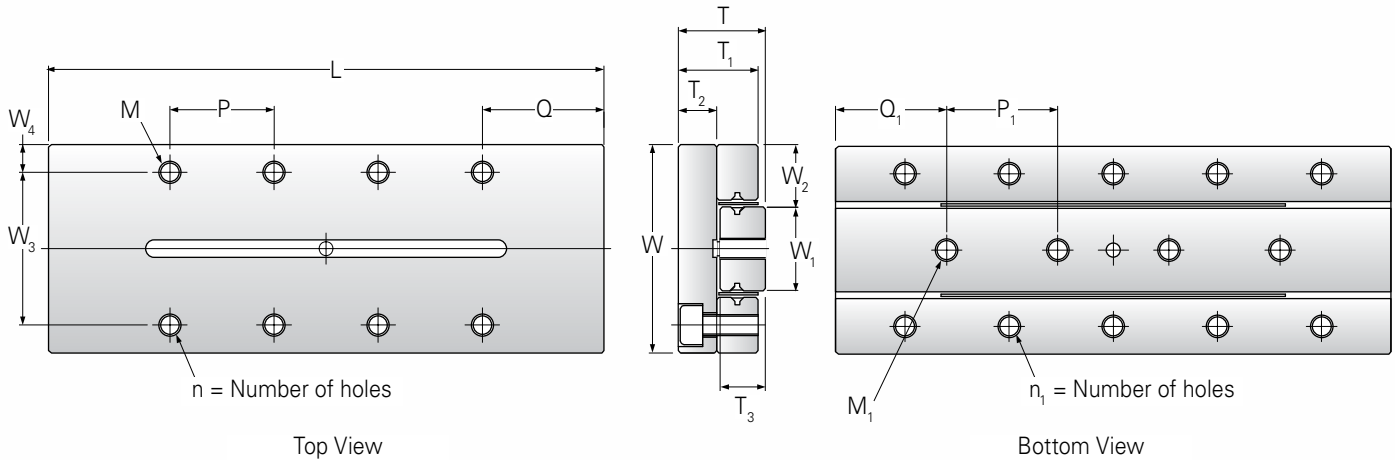

Model		Max. Stroke (mm)	Roller Dia. (mm)	MAIN DIMENSIONS (mm)			TABLE DIMENSIONS (mm)									
Standard	Nickel-plated			W	T	L	W ₃	W ₄	n	P	Q	M	Q ₁	d ₃	T ₁	T ₂
GRC20 - 25	GRC20 - 25 - N	12	Ø 1.5	20 ±0.1	8 ±0.1	25	14	3	4	18	3.5	M2.5	7.5	4.1	7.5	3.5
GRC20 - 35	GRC20 - 35 - N	18	Ø 1.5	20 ±0.1	8 ±0.1	35	14	3	4	28	3.5	M2.5	7.5	4.1	7.5	3.5
GRC20 - 45	GRC20 - 45 - N	25	Ø 1.5	20 ±0.1	8 ±0.1	45	14	3	4	20	12.5	M2.5	7.5	4.1	7.5	3.5
GRC20 - 55	GRC20 - 55 - N	32	Ø 1.5	20 ±0.1	8 ±0.1	55	14	3	4	30	12.5	M2.5	7.5	4.1	7.5	3.5
GRC30 - 65	GRC30 - 65 - N	40	Ø 2.0	30 ±0.1	12 ±0.1	65	22	4	4	30	17.5	M3	10	6	11.5	5.5
GRC30 - 80	GRC30 - 80 - N	50	Ø 2.0	30 ±0.1	12 ±0.1	80	22	4	4	45	17.5	M3	10	6	11.5	5.5
GRC30 - 95	GRC30 - 95 - N	60	Ø 2.0	30 ±0.1	12 ±0.1	95	22	4	6	30	17.5	M3	10	6	11.5	5.5
GRC40 - 105	GRC40 - 105 - N	60	Ø 3.0	40 ±0.1	16 ±0.1	105	30	5	4	50	27.5	M4	15	7.5	15.5	7.5
GRC40 - 130	GRC40 - 130 - N	75	Ø 3.0	40 ±0.1	16 ±0.1	130	30	5	4	75	27.5	M4	15	7.5	15.5	7.5
GRC40 - 155	GRC40 - 155 - N	90	Ø 3.0	40 ±0.1	16 ±0.1	155	30	5	6	50	27.5	M4	15	7.5	15.5	7.5

Model Number Explanation

GR C 20 - 25 - N
 Roller Mounting Type Width Length Nickel-plated

MATERIAL SPECIFICATION

Model number	Table	Rail	Retainer	Roller
GRC	Aluminum alloy + black anodized	SUJ2	SUS304	SUJ2
GRC-N	S50C + Ni	SUJ2 + Ni	SUS304	SUJ2

GRC-N no precision ground finish to V - groove surface of the rail.



GRC



GRC-N

BASE MOUNTING DIMENSIONS (mm)								BASIC LOAD RATING (N)		STATIC RATED MOMENT (N-m)			CAPACITY PER ROLLER BEARING* (N)	WEIGHT (kg)		LINEAR ACCURACY (µm)	
W ₁	W ₂	n ₁	P ₁	Q ₁	M ₁	T ₃	Dynamic	Static	M _A	M _B	M _C	Standard		Nickel-plated	Center	Side	
7	6.5	6	7.5	5	M2.5	4	523	865	2.6	2.2	2.2	288	0.02	0.03	2	4	
7	6.5	6	10	7.5	M2.5	4	657	1,153	4.6	5.2	3.0	384	0.03	0.06	2	4	
7	6.5	8	10	7.5	M2.5	4	783	1,441	7.2	7.9	3.7	480	0.03	0.05	2	4	
7	6.5	10	10	7.5	M2.5	4	903	1,729	10.4	11.2	4.4	576	0.04	0.06	2	5	
12	9	8	15	10	M3	6	1,849	2,924	19.5	21.4	12.7	975	0.11	0.16	2	5	
12	9	10	15	10	M3	6	2,407	4,093	38.2	35.5	17.7	1,364	0.13	0.20	2	5	
12	9	12	15	10	M3	6	2,672	4,678	49.9	46.8	20.3	1,559	0.16	0.24	2	5	
16	12	8	25	15	M4	8	5,646	10,655	124.3	133.2	61.8	3,552	0.31	0.48	3	6	
16	12	10	25	15	M4	8	6,872	13,700	205.5	194.1	79.5	4,567	0.39	0.59	3	6	
16	12	12	25	15	M4	8	8,038	16,744	307.0	293.0	97.1	5,581	0.46	0.70	3	6	

* For calculating cross roller rail load rating, see page 114.

CROSS ROLLER RAILS

GRM / GRM-N (NICKEL-PLATED) TYPE M - TOP MOUNT
TABLE WIDTHS 30 - 40
TABLE LENGTH 25 THRU 185

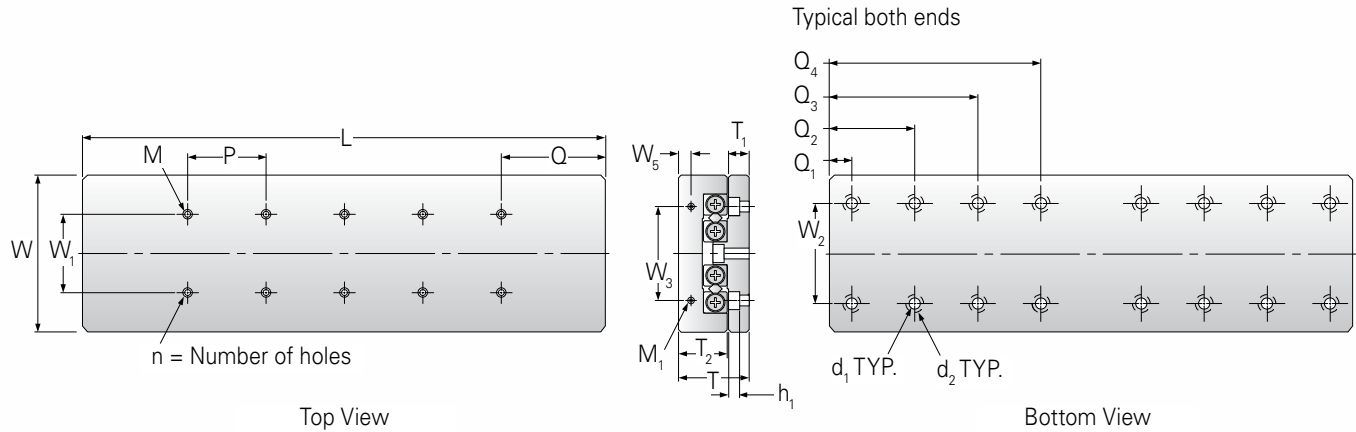

Model		Max. Stroke (mm)	Roller Dia. (mm)	MAIN DIMENSIONS (mm)				TABLE DIMENSIONS (mm)					EXTERNAL CONNECTION MOUNTING DIMENSIONS (mm)		
Standard	Nickel-plated			W	T	T ₂	L	W ₁	M	Q	n	P	W ₃	W ₅	M ₁
GRM30 - 25	GRM30 - 25 - N	12	Ø 1.5	30 ^{-0.2} _{-0.4}	17±0.1	11	25	10	M2 × 4L	12.5	2	—	12	2.5	M2 × 6L
GRM30 - 35	GRM30 - 35 - N	18	Ø 1.5	30 ^{-0.2} _{-0.4}	17±0.1	11	35	10	M2 × 4L	12.5	4	10	12	2.5	M2 × 6L
GRM30 - 45	GRM30 - 45 - N	25	Ø 1.5	30 ^{-0.2} _{-0.4}	17±0.1	11	45	10	M2 × 4L	12.5	6	10	12	2.5	M2 × 6L
GRM30 - 55	GRM30 - 55 - N	32	Ø 1.5	30 ^{-0.2} _{-0.4}	17±0.1	11	55	10	M2 × 4L	12.5	8	10	12	2.5	M2 × 6L
GRM30 - 65	GRM30 - 65 - N	40	Ø 1.5	30 ^{-0.2} _{-0.4}	17±0.1	11	65	10	M2 × 4L	12.5	10	10	12	2.5	M2 × 6L
GRM30 - 75	GRM30 - 75 - N	45	Ø 1.5	30 ^{-0.2} _{-0.4}	17±0.1	11	75	10	M2 × 4L	12.5	12	10	12	2.5	M2 × 6L
GRM30 - 85	GRM30 - 85 - N	50	Ø 1.5	30 ^{-0.2} _{-0.4}	17±0.1	11	85	10	M2 × 4L	12.5	14	10	12	2.5	M2 × 6L
GRM40 - 35	GRM40 - 35 - N	18	Ø 2.0	40 ^{-0.2} _{-0.4}	21±0.1	14	35	15	M3 × 6L	17.5	2	—	16	3.4	M2 × 6L
GRM40 - 50	GRM40 - 50 - N	30	Ø 2.0	40 ^{-0.2} _{-0.4}	21±0.1	14	50	15	M3 × 6L	17.5	4	15	16	3.4	M2 × 6L
GRM40 - 65	GRM40 - 65 - N	40	Ø 2.0	40 ^{-0.2} _{-0.4}	21±0.1	14	65	15	M3 × 6L	17.5	6	15	16	3.4	M2 × 6L
GRM40 - 80	GRM40 - 80 - N	50	Ø 2.0	40 ^{-0.2} _{-0.4}	21±0.1	14	80	15	M3 × 6L	17.5	8	15	16	3.4	M2 × 6L
GRM40 - 95	GRM40 - 95 - N	60	Ø 2.0	40 ^{-0.2} _{-0.4}	21±0.1	14	95	15	M3 × 6L	17.5	10	15	16	3.4	M2 × 6L
GRM40 - 110	GRM40 - 110 - N	70	Ø 2.0	40 ^{-0.2} _{-0.4}	21±0.1	14	110	15	M3 × 6L	17.5	12	15	16	3.4	M2 × 6L
GRM40 - 125	GRM40 - 125 - N	80	Ø 2.0	40 ^{-0.2} _{-0.4}	21±0.1	14	125	15	M3 × 6L	17.5	14	15	16	3.4	M2 × 6L
GRM40 - 140	GRM60 - 140 - N	90	Ø 2.0	40 ^{-0.2} _{-0.4}	21±0.1	14	140	15	M3 × 6L	17.5	16	15	16	3.4	M2 × 6L
GRM40 - 155	GRM60 - 155 - N	100	Ø 2.0	40 ^{-0.2} _{-0.4}	21±0.1	14	155	15	M3 × 6L	17.5	18	15	16	3.4	M2 × 6L
GRM40 - 170	GRM60 - 170 - N	110	Ø 2.0	40 ^{-0.2} _{-0.4}	21±0.1	14	170	15	M3 × 6L	17.5	20	15	16	3.4	M2 × 6L
GRM40 - 185	GRM60 - 185 - N	120	Ø 2.0	40 ^{-0.2} _{-0.4}	21±0.1	14	185	15	M3 × 6L	17.5	22	15	16	3.4	M2 × 6L

Model Number Explanation

GR B 01 - 20 - S
 Roller Mounting Type Width Length Nickel-plated

MATERIAL SPECIFICATION

Model number	table	Rail	Retainer	Roller
GRM	Aluminum alloy + black anodized	SUJ2	SUS304	SUJ2
GRM-N	S50C + Ni	SUJ2 + Ni	SUS304	SUJ2

GRM-N no precision ground finish to V - groove surface of the rail.



GRM



GRM-N

	BASE MOUNTING DIMENSIONS (mm)									BASIC LOAD RATING (N)		STATIC RATED MOMENT (N-m)			CAPACITY PER ROLLER BEARING* (N)	WEIGHT (kg)		LINEAR ACCURACY (µm)	
	W ₂	d ₁	d ₂	h ₁	T ₁	Q ₁	Q ₂	Q ₃	Q ₄	Dynamic	Static	M _A	M _B	M _C		Standard	Nickel-plated	Center	Side
	22	2.5	4.5	2.5	5.5	3.5	—	—	—	379	576	1.2	1.4	2.6	192	0.04	0.09	2	4
	22	2.5	4.5	2.5	5.5	3.5	—	—	—	523	865	2.6	3.0	3.9	288	0.05	0.12	2	4
	22	2.5	4.5	2.5	5.5	3.5	—	—	—	657	1,153	4.6	5.2	5.2	384	0.07	0.16	2	4
	22	2.5	4.5	2.5	5.5	3.5	13.5	—	—	783	1,441	7.2	7.9	6.5	480	0.08	0.19	2	5
	22	2.5	4.5	2.5	5.5	3.5	13.5	—	—	903	1,729	10.4	11.2	7.8	576	0.10	0.23	2	5
	22	2.5	4.5	2.5	5.5	3.5	13.5	—	—	1,131	2,306	18.4	17.3	10.4	769	0.12	0.27	2	5
	22	2.5	4.5	2.5	5.5	3.5	13.5	—	—	1,240	2,594	23.3	22.0	11.7	865	0.13	0.30	2	5
	30	3.5	6.5	3.5	6.5	5	—	—	—	895	1,170	3.1	3.9	7.0	390	0.09	0.20	2	4
	30	3.5	6.5	3.5	6.5	5	—	—	—	1,552	2,339	12.5	10.9	14.0	780	0.13	0.29	2	4
	30	3.5	6.5	3.5	6.5	5	—	—	—	1,849	2,924	19.5	17.5	17.5	975	0.17	0.38	2	5
	30	3.5	6.5	3.5	6.5	5	20	—	—	2,134	3,509	28.1	30.4	21.1	1,170	0.21	0.46	2	5
	30	3.5	6.5	3.5	6.5	5	20	—	—	2,407	4,093	38.2	40.9	24.6	1,364	0.25	0.55	2	5
	30	3.5	6.5	3.5	6.5	5	20	—	—	2,930	5,263	63.2	59.6	31.6	1,754	0.30	0.64	3	6
	30	3.5	6.5	3.5	6.5	5	20	—	—	3,181	5,848	78.0	74.1	35.1	1,949	0.34	0.73	3	6
	30	3.5	6.5	3.5	6.5	5	20	35	—	3,427	6,433	94.3	98.6	38.6	2,144	0.38	0.82	3	6
	30	3.5	6.5	3.5	6.5	5	20	35	—	3,668	7,017	112.3	117.0	42.1	2,339	0.42	0.91	3	6
	30	3.5	6.5	3.5	6.5	5	20	35	—	4,136	8,187	152.8	147.4	49.1	2,729	0.46	1.00	3	7
	30	3.5	6.5	3.5	6.5	5	20	35	50	4,365	8,772	175.4	169.6	52.6	2,924	0.50	1.08	3	7

* For calculating cross roller rail load rating, see page 114.

CROSS ROLLER RAILS

GRM / GRM-N (NICKEL-PLATED) TYPE M - TOP MOUNT
TABLE WIDTH 60
TABLE LENGTH 55 THRU 305

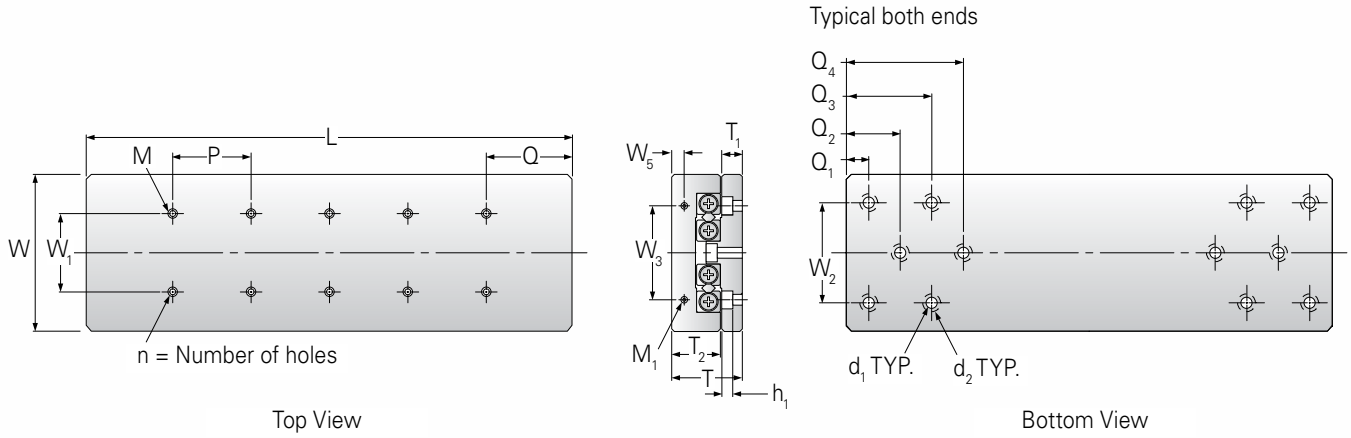

Model		Max. Stroke (mm)	Roller Dia. (mm)	MAIN DIMENSIONS (mm)				TABLE DIMENSIONS (mm)					EXTERNAL CONNECTION MOUNTING DIMENSIONS (mm)		
Standard	Nickel-plated			W	T	T ₂	L	W ₁	M	Q	n	P	W ₃	W ₅	M ₁
GRM60 - 55	GRM60 - 55 - N	30	Ø 3.0	60±0.1	28±0.1	18.5	55	25	M4 × 8L	27.5	2	—	40	5.5	M3 × 6L
GRM60 - 80	GRM60 - 80 - N	45	Ø 3.0	60±0.1	28±0.1	18.5	80	25	M4 × 8L	27.5	4	25	40	5.5	M3 × 6L
GRM60 - 105	GRM60 - 105 - N	60	Ø 3.0	60±0.1	28±0.1	18.5	105	25	M4 × 8L	27.5	6	25	40	5.5	M3 × 6L
GRM60 - 130	GRM60 - 130 - N	75	Ø 3.0	60±0.1	28±0.1	18.5	130	25	M4 × 8L	27.5	8	25	40	5.5	M3 × 6L
GRM60 - 155	GRM60 - 155 - N	90	Ø 3.0	60±0.1	28±0.1	18.5	155	25	M4 × 8L	27.5	10	25	40	5.5	M3 × 6L
GRM60 - 180	GRM60 - 180 - N	105	Ø 3.0	60±0.1	28±0.1	18.5	180	25	M4 × 8L	27.5	12	25	40	5.5	M3 × 6L
GRM60 - 205	GRM60 - 205 - N	130	Ø 3.0	60±0.1	28±0.1	18.5	205	25	M4 × 8L	27.5	14	25	40	5.5	M3 × 6L
GRM60 - 230	GRM60 - 230 - N	155	Ø 3.0	60±0.1	28±0.1	18.5	230	25	M4 × 8L	27.5	16	25	40	5.5	M3 × 6L
GRM60 - 255	GRM60 - 255 - N	180	Ø 3.0	60±0.1	28±0.1	18.5	255	25	M4 × 8L	27.5	18	25	40	5.5	M3 × 6L
GRM60 - 280	GRM60 - 280 - N	205	Ø 3.0	60±0.1	28±0.1	18.5	280	25	M4 × 8L	27.5	20	25	40	5.5	M3 × 6L
GRM60 - 305	GRM60 - 305 - N	305	Ø 3.0	60±0.1	28±0.1	18.5	305	25	M4 × 8L	27.5	22	25	40	5.5	M3 × 6L

Model Number Explanation

GR M 80 - 55 - N
 Roller Mounting Type Width Length Nickel-plated

MATERIAL SPECIFICATION

Model number	table	Rail	Retainer	Roller
GRM	Aluminum alloy + black anodized	SUJ2	SUS304	SUJ2
GRM-N	S50C + Ni	SUJ2 + Ni	SUS304	SUJ2

GRM-N no precision ground finish to V - groove surface of the rail.



W ₂	BASE MOUNTING DIMENSIONS (mm)										BASIC LOAD RATING (N)		STATIC RATED MOMENT (N·m)			CAPACITY PER ROLLER BEARING* (N)	WEIGHT (kg)		LINEAR ACCURACY (μm)	
	d ₁	d ₂	h ₁	T ₁	h ₂	Q ₁	Q ₂	Q ₃	Q ₇	Dynamic	Static	M _A	M _B	M _C	Standard		Nickel-plated	Center	Side	
40	4.5	8	4.5	9	15	10	—	—	—	2,901	4,567	22.8	26.6	42.6	1,522	0.29	0.66	2	5	
40	4.5	8	4.5	9	15	10	—	—	—	4,338	7,611	63.4	57.1	71.0	2,537	0.43	0.96	2	5	
40	4.5	8	4.5	9	15	10	—	—	—	5,646	10,655	124.3	115.4	99.5	3,552	0.57	1.26	3	6	
40	4.5	8	4.5	9	15	10	—	—	—	6,268	12,178	162.4	172.5	113.7	4,059	0.71	1.57	3	6	
40	4.5	8	4.5	9	15	10	35	—	—	7,462	15,222	253.7	266.4	142.1	5,074	0.84	1.87	3	6	
40	4.5	8	4.5	9	15	10	35	—	—	8,603	18,266	365.3	350.1	170.5	6,089	0.98	2.17	3	7	
40	4.5	8	4.5	9	15	10	35	60	—	9,157	19,789	428.8	445.2	184.7	6,596	1.12	2.47	3	7	
40	4.5	8	4.5	9	15	10	35	60	—	9,702	21,311	497.3	515.0	198.9	7,104	1.25	2.77	3	7	
40	4.5	8	4.5	9	15	10	35	60	—	10,767	24,355	649.5	629.2	227.3	8,118	1.39	3.07	3	7	
40	4.5	8	4.5	9	15	10	35	60	85	11,288	25,877	733.2	711.6	241.5	8,626	1.53	3.37	3	7	
40	4.5	8	4.5	9	15	10	35	60	85	11,802	27,400	822.0	844.8	255.7	9,133	1.66	3.68	3	7	

* For calculating cross roller rail load rating, see page 114.

GRM / GRM-N (NICKEL-PLATED) TYPE M - TOP MOUNT
TABLE WIDTHS 80 - 100
TABLE LENGTH 85 THRU 510

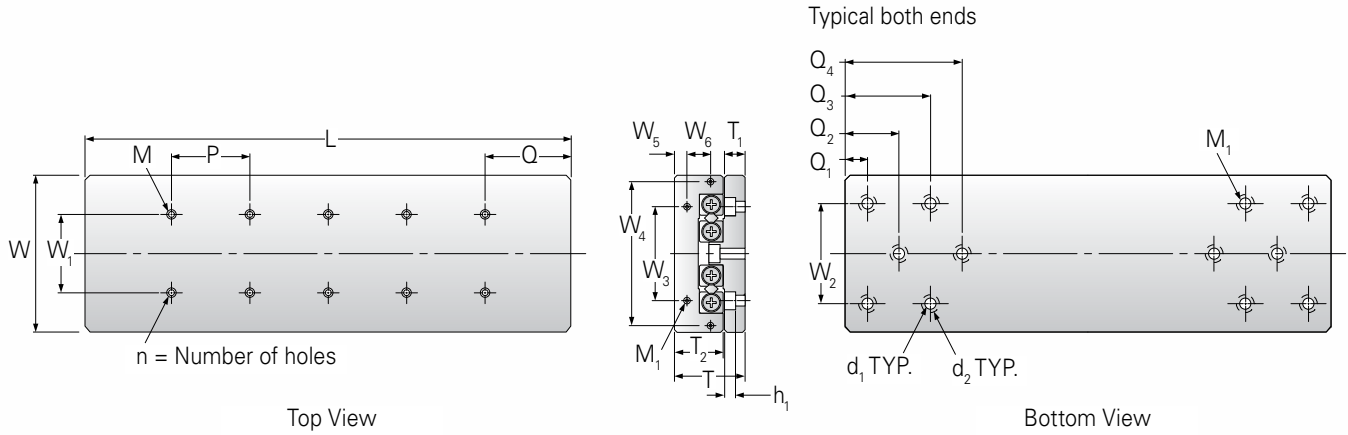

Model		Max. Stroke (mm)	Roller Dia. (mm)	MAIN DIMENSIONS (mm)				TABLE DIMENSIONS (mm)					EXTERNAL CONNECTION MOUNTING DIMENSIONS (mm)				
Standard	Nickel-plated			W	T	T ₂	L	W ₁	M	Q	n	P	W ₃	W ₄	W ₅	W ₆	M ₁
GRM80 - 85	GRM80 - 85 - N	50	Ø 4.0	80 ±0.1	35 ±0.1	24	85	40	M5 × 10L	42.5	2	—	55	—	6.5	—	M3 × 6L
GRM80 - 125	GRM80 - 125 - N	75	Ø 4.0	80 ±0.1	35 ±0.1	24	125	40	M5 × 10L	42.5	4	40	55	—	6.5	—	M3 × 6L
GRM80 - 165	GRM80 - 165 - N	105	Ø 4.0	80 ±0.1	35 ±0.1	24	165	40	M5 × 10L	42.5	6	40	55	—	6.5	—	M3 × 6L
GRM80 - 205	GRM80 - 205 - N	130	Ø 4.0	80 ±0.1	35 ±0.1	24	205	40	M5 × 10L	42.5	8	40	55	—	6.5	—	M3 × 6L
GRM80 - 245	GRM80 - 245 - N	155	Ø 4.0	80 ±0.1	35 ±0.1	24	245	40	M5 × 10L	42.5	10	40	55	—	6.5	—	M3 × 6L
GRM80 - 285	GRM80 - 285 - N	185	Ø 4.0	80 ±0.1	35 ±0.1	24	285	40	M5 × 10L	42.5	12	40	55	—	6.5	—	M3 × 6L
GRM80 - 325	GRM80 - 325 - N	210	Ø 4.0	80 ±0.1	35 ±0.1	24	325	40	M5 × 10L	42.5	14	40	55	—	6.5	—	M3 × 6L
GRM80 - 365	GRM80 - 365 - N	235	Ø 4.0	80 ±0.1	35 ±0.1	24	365	40	M5 × 10L	42.5	16	40	55	—	6.5	—	M3 × 6L
GRM80 - 405	GRM80 - 405 - N	265	Ø 4.0	80 ±0.1	35 ±0.1	24	405	40	M5 × 10L	42.5	18	40	55	—	6.5	—	M3 × 6L
GRM80 - 110	GRM80 - 110 - N	60	Ø 6.0	100 ±0.1	45 ±0.1	31	110	50	M6 × 12L	55	2	—	60	92	8	15	M4 × 8L
GRM100 - 160	GRM100 - 160 - N	95	Ø 6.0	100 ±0.1	45 ±0.1	31	160	50	M6 × 12L	55	4	50	60	92	8	15	M4 × 8L
GRM100 - 210	GRM100 - 210 - N	130	Ø 6.0	100 ±0.1	45 ±0.1	31	210	50	M6 × 12L	55	6	50	60	92	8	15	M4 × 8L
GRM100 - 260	GRM100 - 260 - N	165	Ø 6.0	100 ±0.1	45 ±0.1	31	260	50	M6 × 12L	55	8	50	60	92	8	15	M4 × 8L
GRM100 - 310	GRM100 - 310 - N	200	Ø 6.0	100 ±0.1	45 ±0.1	31	310	50	M6 × 12L	55	10	50	60	92	8	15	M4 × 8L
GRM100 - 360	GRM100 - 360 - N	235	Ø 6.0	100 ±0.1	45 ±0.1	31	360	50	M6 × 12L	55	12	50	60	92	8	15	M4 × 8L
GRM100 - 410	GRM100 - 410 - N	265	Ø 6.0	100 ±0.1	45 ±0.1	31	410	50	M6 × 12L	55	14	50	60	92	8	15	M4 × 8L
GRM100 - 460	GRM100 - 460 - N	300	Ø 6.0	100 ±0.1	45 ±0.1	31	460	50	M6 × 12L	55	16	50	60	92	8	15	M4 × 8L
GRM100 - 510	GRM100 - 510 - N	335	Ø 6.0	100 ±0.1	45 ±0.1	31	540	50	M6 × 12L	55	18	50	60	92	8	15	M4 × 8L

Model Number Explanation

GR M 80 - 85 - N
 Roller Mounting Type Width Length Nickel-plated

MATERIAL SPECIFICATION

Model number	Table	Rail	Retainer	Roller
GRM	Aluminum alloy + black anodized	SUJ2	SUS304	SUJ2
GRM-N	S50C + Ni	SUJ2 + Ni	SUS304	SUJ2

GRM-N no precision ground finish to V - groove surface of the rail.



BASE MOUNTING DIMENSIONS (mm)										BASIC LOAD RATING (N)		STATIC RATED MOMENT (N-m)			CAPACITY PER ROLLER BEARING* (N)	WEIGHT (kg)		LINEAR ACCURACY (μm)	
W ₂	d ₁	d ₂	h ₁	T ₁	h ₂	Q ₁	Q ₂	Q ₃	Q ₄	Dynamic	Static	M _A	M _B	M _C		Standard	Nickel-plated	Center	Side
55	5.5	10	5.4	10.5	10.5	10.5	—	—	—	6,617	9,357	87.3	76.4	124.8	3119	0.76	1.69	2	5
55	5.5	10	5.4	10.5	10.5	10.5	—	—	—	9,097	14,035	196.5	180.1	187.1	4,678	1.12	2.50	3	6
55	5.5	10	5.4	10.5	10.5	10.5	—	—	—	10,264	16,375	267.5	286.6	218.3	5,458	1.48	3.31	3	7
55	5.5	10	5.4	10.5	10.5	10.5	50	—	—	12,492	21,053	442.1	466.7	280.7	7,018	1.84	4.11	3	7
55	5.5	10	5.4	10.5	10.5	10.5	50	—	—	14,612	25,732	660.4	690.5	343.1	8,577	2.20	4.91	3	7
55	5.5	10	5.4	10.5	10.5	10.5	50	—	—	16,646	30,410	922.4	957.9	405.5	10,137	2.56	5.72	3	7
55	5.5	10	5.4	10.5	10.5	10.5	50	90	—	18,612	35,089	1,228.1	1,269.0	467.8	11,696	2.92	6.51	4	8
55	5.5	10	5.4	10.5	10.5	10.5	50	90	—	20,519	39,767	1,577.4	1,623.8	530.2	13,256	3.28	7.32	4	8
55	5.5	10	5.4	10.5	10.5	10.5	50	90	—	22,377	44,445	1,970.4	1,918.6	592.6	14,815	3.65	8.13	4	8
60	7	11.5	7	13	23	10	—	—	—	13,923	21,053	252.6	221.1	315.8	7,018	1.60	3.48	3	6
60	7	11.5	7	13	23	10	—	—	—	16,592	26,316	394.7	434.2	394.7	8,772	2.36	5.10	3	6
60	7	11.5	7	13	23	10	60	—	—	21,596	36,842	773.7	828.9	552.6	12,281	3.11	6.70	3	7
60	7	11.5	7	13	23	10	60	—	—	26,285	47,369	1,279.0	1,207.9	710.5	15,790	3.86	8.32	3	7
60	7	11.5	7	13	23	10	60	—	—	30,744	57,895	1,910.5	1,823.7	868.4	19,298	4.62	9.94	3	7
60	7	11.5	7	13	23	10	60	110	—	35,024	68,421	2,688.4	2,565.8	1,026.3	22,807	5.36	11.53	4	8
60	7	11.5	7	13	23	10	60	110	—	39,160	78,948	3,552.6	3,434.2	1,184.2	26,316	6.12	13.15	4	8
60	7	11.5	7	13	23	10	60	110	—	41,181	84,211	4,042.1	4,168.4	1,263.2	28,070	6.87	14.76	4	8
60	7	11.5	7	13	23	10	60	110	160	45,141	94,737	5,115.8	5,257.9	1,421.1	31,579	7.62	16.36	4	8

* For calculating cross roller rail load rating, see page 114.

GRH / GRH-N (NICKEL-PLATED) TYPE H - TOP MOUNT
TABLE WIDTHS 20 - 30 - 40
TABLE LENGTH 25 THRU 205

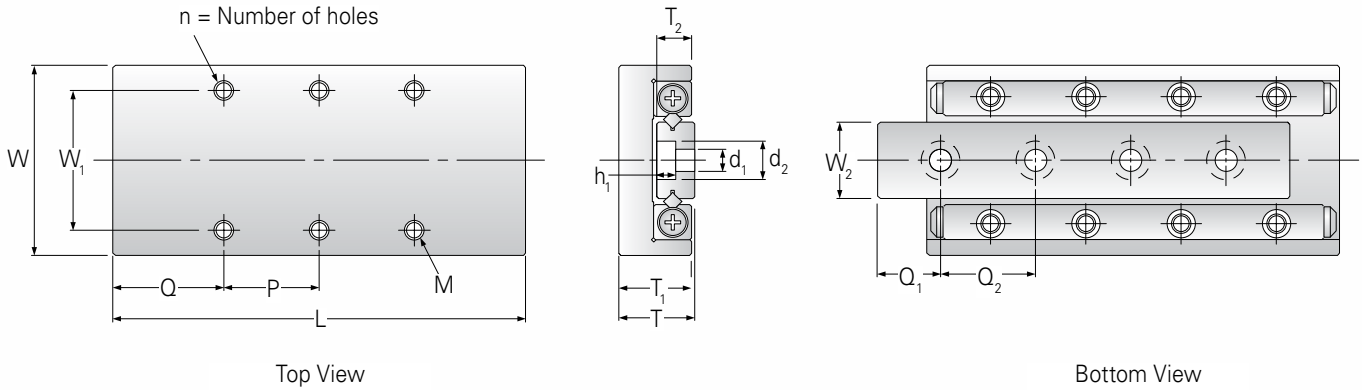

Model		Max. Stroke (mm)	Roller Dia. (mm)	MAIN DIMENSIONS (mm)						TABLE DIMENSIONS (mm)				
Standard	Nickel-plated			W	T	L	T ₁	T ₂	W ₂	W ₁	M	Q	n	P
GRH20 - 25	GRH20 - 25 - N	12	Ø 1.5	20 ±0.1	8 ±0.1	25	7.5	4	6.6	14	M2.5 × 3.5L	3.5	4	18
GRH20 - 35	GRH20 - 35 - N	18	Ø 1.5	20 ±0.1	8 ±0.1	35	7.5	4	6.6	14	M2.5 × 3.5L	3.5	4	28
GRH20 - 45	GRH20 - 45 - N	25	Ø 1.5	20 ±0.1	8 ±0.1	45	7.5	4	6.6	14	M2.5 × 3.5L	12.5	4	20
GRH20 - 55	GRH20 - 55 - N	32	Ø 1.5	20 ±0.1	8 ±0.1	55	7.5	4	6.6	14	M2.5 × 3.5L	12.5	4	30
GRH20 - 65	GRH20 - 65 - N	40	Ø 1.5	20 ±0.1	8 ±0.1	65	7.5	4	6.6	14	M2.5 × 3.5L	12.5	6	20
GRH20 - 75	GRH20 - 75 - N	45	Ø 1.5	20 ±0.1	8 ±0.1	75	7.5	4	6.6	14	M2.5 × 3.5L	22.5	4	30
GRH20 - 85	GRH20 - 85 - N	50	Ø 1.5	20 ±0.1	8 ±0.1	85	7.5	4	6.6	14	M2.5 × 3.5L	12.5	6	30
GRH30 - 35	GRH30 - 35 - N	18	Ø 2.0	30 ±0.1	12 ±0.1	35	11.5	6	12.0	22	M3.5 × 5.5L	3.5	4	28
GRH30 - 50	GRH30 - 50 - N	30	Ø 2.0	30 ±0.1	12 ±0.1	50	11.5	6	12.0	22	M3.5 × 5.5L	3.5	4	43
GRH30 - 65	GRH30 - 65 - N	40	Ø 2.0	30 ±0.1	12 ±0.1	65	11.5	6	12.0	22	M3.5 × 5.5L	17.5	4	30
GRH30 - 80	GRH30 - 80 - N	50	Ø 2.0	30 ±0.1	12 ±0.1	80	11.5	6	12.0	22	M3.5 × 5.5L	17.5	4	45
GRH30 - 95	GRH30 - 95 - N	60	Ø 2.0	30 ±0.1	12 ±0.1	95	11.5	6	12.0	22	M3.5 × 5.5L	17.5	6	30
GRH30 - 110	GRH30 - 110 - N	70	Ø 2.0	30 ±0.1	12 ±0.1	110	11.5	6	12.0	22	M3.5 × 5.5L	32.5	4	45
GRH30 - 125	GRH30 - 125 - N	80	Ø 2.0	30 ±0.1	12 ±0.1	125	11.5	6	12.0	22	M3.5 × 5.5L	17.5	6	45
GRH40 - 55	GRH40 - 55 - N	30	Ø 3.0	40 ±0.1	16 ±0.1	55	15.5	8	16	30	M4 × 7.5L	7.5	4	40
GRH40 - 80	GRH40 - 80 - N	45	Ø 3.0	40 ±0.1	16 ±0.1	80	15.5	8	16	30	M4 × 7.5L	7.5	4	65
GRH40 - 105	GRH40 - 105 - N	60	Ø 3.0	40 ±0.1	16 ±0.1	105	15.5	8	16	30	M4 × 7.5L	27.5	4	50
GRH40 - 130	GRH40 - 130 - N	75	Ø 3.0	40 ±0.1	16 ±0.1	130	15.5	8	16	30	M4 × 7.5L	27.5	4	75
GRH40 - 155	GRH40 - 155 - N	90	Ø 3.0	40 ±0.1	16 ±0.1	155	15.5	8	16	30	M4 × 7.5L	27.5	6	50
GRH40 - 180	GRH40 - 180 - N	105	Ø 3.0	40 ±0.1	16 ±0.1	180	15.5	8	16	30	M4 × 7.5L	52.5	4	75
GRH40 - 205	GRH40 - 205 - N	130	Ø 3.0	40 ±0.1	16 ±0.1	205	15.5	8	16	30	M4 × 7.5L	27.5	6	75

Model Number Explanation

GR H 20 - 25 - N
 Roller Mounting Type Width Length Nickel-plated

MATERIAL SPECIFICATION

Model number	Table	Rail	Retainer	Roller
GRH	Aluminum alloy + black anodized	SUJ2	SUS304	SUJ2
GRH-N	S50C + Ni	SUJ2 + Ni	SUS304	SUJ2

GRH-N no precision ground finish to V - groove surface of the rail.



BASE MOUNTING DIMENSIONS (mm)					BASIC LOAD RATING (N)		STATIC RATED MOMENT (N-m)			CAPACITY PER ROLLER BEARING* (N)	WEIGHT (kg)		LINEAR ACCURACY (μm)	
d ₁	d ₂	h ₁	Q ₁	Q ₂	Dynamic	Static	M _A	M _B	M _C		Standard	Nickel-plated	Center	Side
2.5	4.1	2.2	3.5	—	379	576	1.2	1.4	1.4	192	0.01	0.02	2	4
2.5	4.1	2.2	5	—	523	865	2.6	3.0	2.2	288	0.02	0.03	2	4
2.5	4.1	2.2	3.5	10	657	1,153	4.6	5.2	2.9	384	0.03	0.04	2	5
2.5	4.1	2.2	3.5	13	783	1,441	7.2	7.9	3.6	480	0.03	0.05	2	5
2.5	4.1	2.2	5	17	903	1,729	10.4	11.2	4.3	576	0.04	0.06	2	5
2.5	4.1	2.2	5	20	1,131	2,306	18.4	17.3	5.8	769	0.05	0.08	2	5
2.5	4.1	2.2	5	22.5	1,240	2,594	23.3	22.0	6.5	865	0.05	0.09	2	5
3.5	6	3.3	5	—	895	1,170	3.1	3.9	5.1	390	0.05	0.05	2	4
3.5	6	3.3	7.5	—	1,552	2,339	12.5	10.9	10.1	780	0.07	0.12	2	4
3.5	6	3.3	5	16	1,849	2,924	19.5	17.5	12.7	975	0.09	0.15	2	5
3.5	6	3.3	5	20	2,164	3,509	28.1	30.4	15.2	1,170	0.11	.019	2	5
3.5	6	3.3	5	25	2,407	4,093	38.2	40.9	17.7	1,364	0.14	0.23	2	5
3.5	6	3.3	7.5	30	2,930	5,263	63.2	59.6	22.8	1,754	0.16	0.26	2	5
3.5	6	3.3	7.5	35	3,181	5,848	78.0	74.1	25.3	1,949	0.18	0.30	2	5
4.5	7.1	4.3	7.5	—	2,901	4,567	22.8	26.6	26.5	1,522	0.15	0.24	2	5
4.5	7.1	4.3	6	18.5	4,338	7,611	63.4	57.1	44.1	2,537	0.21	0.35	2	5
4.5	7.1	4.3	7.5	25	5,646	10,655	124.3	115.4	61.8	3,552	0.28	0.46	3	5
4.5	7.1	4.3	7.5	32.5	6,268	12,178	162.4	172.5	70.6	4,059	0.35	0.57	3	5
4.5	7.1	4.3	7.5	30	7,462	15,222	253.7	266.4	88.3	5,074	0.42	0.68	3	5
4.5	7.1	4.3	7.5	47.5	8,603	18,266	365.3	350.1	105.9	6,089	0.49	0.80	3	5
4.5	7.1	4.3	7.5	57.5	9,157	19,789	428.8	445.2	114.8	6,596	0.56	0.91	3	5

* For calculating cross roller rail load rating, see page 114.

GRS / GRS-N (NICKEL-PLATED) TYPE S - BOTTOM MOUNT
TABLE WIDTHS 20 - 40
TABLE LENGTH 25 THRU 205

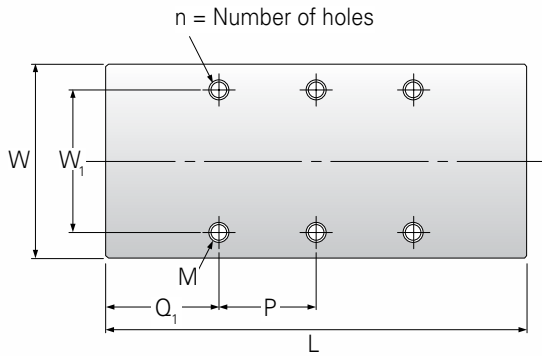

Top View

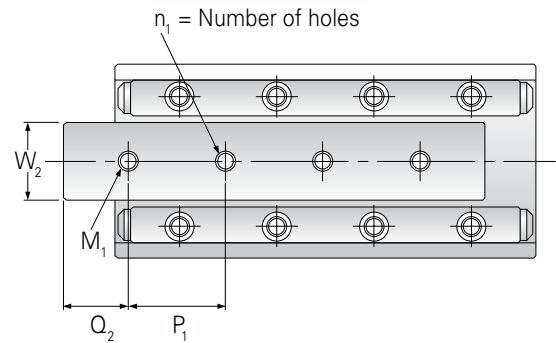
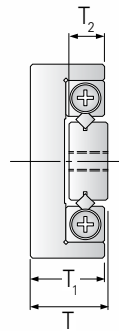

Bottom View

Standard	Model Nickel-plated	Max. Stroke (mm)	Roller Dia. (mm)	MAIN DIMENSIONS (mm)						TABLE DIMENSIONS (mm)				
				W	T	L	T ₁	T ₂	W ₂	W ₁	M	Q	n	P
GRS20 - 25	GRS20 - 25 - N	12	Ø 1.5	20 ±0.1	8 ±0.1	25	7.5	4	6.6	14	M2.5 × 3.5L	3.5	4	18
GRS20 - 35	GRS20 - 35 - N	18	Ø 1.5	20 ±0.1	8 ±0.1	35	7.5	4	6.6	14	M2.5 × 3.5L	3.5	6	28
GRS20 - 45	GRS20 - 45 - N	25	Ø 1.5	20 ±0.1	8 ±0.1	45	7.5	4	6.6	14	M2.5 × 3.5L	12.5	4	20
GRS20 - 55	GRS20 - 55 - N	32	Ø 1.5	20 ±0.1	8 ±0.1	55	7.5	4	6.6	14	M2.5 × 3.5L	12.5	4	30
GRS20 - 65	GRS20 - 65 - N	40	Ø 1.5	20 ±0.1	8 ±0.1	65	7.5	4	6.6	14	M2.5 × 3.5L	12.5	6	20
GRS20 - 75	GRS20 - 75 - N	45	Ø 1.5	20 ±0.1	8 ±0.1	75	7.5	4	6.6	14	M2.5 × 3.5L	22.5	4	30
GRS20 - 85	GRS20 - 85 - N	50	Ø 1.5	20 ±0.1	8 ±0.1	85	7.5	4	6.6	14	M2.5 × 3.5L	12.5	6	30
GRS30 - 35	GRS30 - 35 - N	18	Ø 2.0	30 ±0.1	12 ±0.1	35	11.5	6	12.0	22	M3.5 × 5.5L	3.5	4	28
GRS30 - 50	GRS30 - 50 - N	30	Ø 2.0	30 ±0.1	12 ±0.1	50	11.5	6	12.0	22	M3.5 × 5.5L	3.5	4	43
GRS30 - 65	GRS30 - 65 - N	40	Ø 2.0	30 ±0.1	12 ±0.1	65	11.5	6	12.0	22	M3.5 × 5.5L	17.5	4	30
GRS30 - 80	GRS30 - 80 - N	50	Ø 2.0	30 ±0.1	12 ±0.1	80	11.5	6	12.0	22	M3.5 × 5.5L	17.5	4	45
GRS30 - 95	GRS30 - 95 - N	60	Ø 2.0	30 ±0.1	12 ±0.1	95	11.5	6	12.0	22	M3.5 × 5.5L	17.5	6	30
GRS30 - 110	GRS30 - 110 - N	70	Ø 2.0	30 ±0.1	12 ±0.1	110	11.5	6	12.0	22	M3.5 × 5.5L	32.5	4	45
GRS30 - 125	GRS30 - 125 - N	80	Ø 2.0	30 ±0.1	12 ±0.1	125	11.5	6	12.0	22	M3.5 × 5.5L	17.5	6	45
GRS40 - 55	GRS40 - 55 - N	30	Ø 3.0	40 ±0.1	16 ±0.1	55	15.5	8	16	30	M4 × 7.5L	7.5	4	40
GRS40 - 80	GRS40 - 80 - N	45	Ø 3.0	40 ±0.1	16 ±0.1	80	15.5	8	16	30	M4 × 7.5L	7.5	4	65
GRS40 - 105	GRS40 - 105 - N	60	Ø 3.0	40 ±0.1	16 ±0.1	105	15.5	8	16	30	M4 × 7.5L	27.5	4	50
GRS40 - 130	GRS40 - 130 - N	75	Ø 3.0	40 ±0.1	16 ±0.1	130	15.5	8	16	30	M4 × 7.5L	27.5	4	75
GRS40 - 155	GRS40 - 155 - N	90	Ø 3.0	40 ±0.1	16 ±0.1	155	15.5	8	16	30	M4 × 7.5L	27.5	6	50
GRS40 - 180	GRS40 - 180 - N	105	Ø 3.0	40 ±0.1	16 ±0.1	180	15.5	8	16	30	M4 × 7.5L	52.5	4	75
GRS40 - 205	GRS40 - 205 - N	130	Ø 3.0	40 ±0.1	16 ±0.1	205	15.5	8	16	30	M4 × 7.5L	27.5	6	75

Model Number Explanation

GR S 20 - 25 - N
 Roller Mounting Type Width Length Nickel-plated

MATERIAL SPECIFICATION

Model number	Table	Rail	Retainer	Roller
GRS	Aluminum alloy + black anodized	SUJ2	SUS304	SUJ2
GRS-N	S50C + Ni	SUJ2 + Ni	SUS304	SUJ2

GRS-N no precision ground finish to V - groove surface of the rail.



GRS



GRS-N

BASE MOUNTING DIMENSIONS (mm)				BASIC LOAD RATING (N)		STATIC RATED MOMENT (N-m)			CAPACITY PER ROLLER BEARING* (N)	WEIGHT (kg)		LINEAR ACCURACY (μm)	
M ₁	Q ₁	n ₁	P ₁	Dynamic	Static	M _A	M _B	M _C		Standard	Nickel-plated	Center	Side
M2.6	5	6	7.5	379	576	1.2	1.4	1.4	192	0.01	0.02	2	4
M2.6	7.5	6	10	523	865	2.6	3.0	2.2	288	0.02	0.03	2	4
M2.6	7.5	8	10	657	1,153	4.6	5.2	2.9	384	0.03	0.05	2	5
M2.6	7.5	10	10	783	1,441	7.2	7.9	3.6	480	0.03	0.06	2	5
M2.6	7.5	12	10	903	1,729	10.4	11.2	4.3	576	0.04	0.07	2	5
M2.6	7.5	14	10	1,131	2,306	18.4	17.3	5.8	769	0.05	0.08	2	5
M2.6	7.5	16	10	1,240	2,594	23.3	22.0	6.5	865	0.05	0.09	2	5
M3	7.5	4	20	895	1,170	3.1	3.9	5.1	390	0.05	0.05	2	4
M3	10	6	15	1,552	2,339	12.5	10.9	10.1	780	0.07	0.12	2	4
M3	10	8	15	1,849	2,924	19.5	17.5	12.7	975	0.10	0.16	2	5
M3	10	10	15	2,134	3,509	28.1	30.4	15.2	1,170	0.12	.019	2	5
M3	10	12	15	2,407	4,093	38.2	40.9	17.7	1,364	0.14	0.23	2	5
M3	10	14	15	2,930	5,263	63.2	59.6	22.8	1,949	0.16	0.27	2	5
M3	10	16	15	3,181	5,848	78.0	74.1	25.3	3,044	0.18	0.30	2	5
M4	10	4	35	2,901	4,567	22.8	26.6	26.5	1,522	0.15	0.24	2	5
M4	15	6	25	4,338	7,611	63.4	57.1	44.1	2,537	0.22	0.35	2	5
M4	15	8	25	5,646	10,655	124.3	115.4	61.8	3,552	0.29	0.46	3	5
M4	15	10	25	6,268	12,178	162.4	172.5	70.6	4,059	0.36	0.58	3	5
M4	15	12	25	7,462	15,222	259.7	266.4	88.3	5,074	0.42	0.69	3	5
M4	15	14	25	8,603	18,266	365.3	350.1	105.9	6,089	0.49	0.80	3	5
M5	15	16	25	9,157	19,789	428.8	445.2	114.8	6,596	0.56	0.91	3	5

* For calculating cross roller rail load rating, see page 114.

INDUSTRY MATERIAL STANDARD COMPARISON OF COUNTRIES

HIGH SPEED TOOL STEEL & ALLOY TOOL STEEL

JIS	ISO	AISI	BS	DIN	
		ASTM		VDEh	
SKH51	HS 6 - 5 - 2	M2	BM2	S 6 - 5 - 2	1.3343
SKH55	HS 6 - 5 - 2 - 5	—	BM35	S 6 - 5 - 2 - 5	1.3243
SKS 3	—	—	—	—	1.2419
SKH11	—	D2	BD2	—	1.2379
SKH61	40CrMoV5	H13	BH13	X40CrMoV51	1.2344

HIGH - CARBON CHROME BEARING STEEL

JIS	ISO	AISI	BS	DIN	
		ASTM			
SUJ2	BLor100Cr6	52100	—	100Cr6	1.2067 / 1.3505

CARBON STEEL FOR MACHINE STRUCTURAL USE & CHROME MOLYBDENUM STEEL

JIS	ISO	AISI	BS	DIN	
		ASTM			
S45C	C45	1045	C45	C45	1.0503
	C45E4	0146	C45E	C45E	1.1191
	C45M2		C45R	C45R	1.1193
S50C	C50	1049	080M50	C50	1.1213
	C50E4		C50	C50E	
	C50M2		C50E	C50R	
			C50R		
S55C	C55	1055	070M55	C55	1.0535 / 1.1203
	C55E4		C55	C55E	
	E55M2		C55E	C55R	
			C55R		
SCM430	—	4133	—	—	1.7218
SCM435	34CrMo4	4137	34CrMo4	34CrMo4	1.722
	34CrMoS4		34CrMoS4	34CrMoS4	
SCM440	42CrMo4	4140	708M40	42CrMo4	1.7225
	42CrMoS4	4142	709M40	42CrMoS4	
			42CrMo4		
			42CrMoS4		

STAINLESS STEEL

JIS	ISO	AISI	BS	DIN	
SUS 303	13	303	303S21	X10CrNiS189	1.4305
SUS 304	6	304	304S31	X5CrNiS1810	1.43041
SUS 430	41	430	430S17	X6Cr17	1.4016
SUS 440C	—	440C	—	X105CrMo17	1.4125

ALUMINUM & ALUMINUM ALLOY EXTENDER

JIS H4000 : 88	ISO 6361 : 90	ASTM	BS EN485 - 2 : 95	DIN EN485 - 2 : 95
	ISO 209 : 89	B209 M : 95	BS EN573 - 3 : 95	DIN EN573 - 3 : 95
	AlMg2.5	5052	EN AW - 5052	EN AW - 5052
	—	6061	EM AW - 6061	EM AW - 6061
	AlZn5.5MgCu	7075	EN AW - 7075	EN AW - 7075

LUBRICATION COMPATIBILITY

To prevent lubrication incompatibility problems, avoid mixing lubricants of varying thickeners. Combining lubricants of incompatible thickeners can cause an increased risk of functional and physical problems, such as; viscosity and shear instability, oil filtration and oxidized breakdown, along with increased oil leakage.

If two lubricants with different thickeners are required, the below chart will help in determining compatibility.

Compatibility comparison of different thickeners are as follows:

●	Fully Compatible
◉	Semi Compatible
✘	Incompatible

	Barium Based	Calcium Based	Clay Based	Lithium Based	Urea Based	COMPLEX			12HSA*	
						Aluminum	Calcium	Lithium	Calcium	Lithium
Barium Based		●	●	●	●	●	●	●	✘	●
Calcium Based	●		✘	✘	●	●	●	✘	✘	◉
Clay Based	●	✘		●	●	●	●	✘	✘	●
Lithium Based	●	✘	●		●	●	✘	✘	✘	✘
Urea based	●	●	●	●		●	✘	●	●	●
COMPLEX	Aluminum	●	●	●	●		●	✘	✘	●
	Calcium	●	●	●	●	●		✘	◉	●
	Lithium	●	✘	●	✘	●	✘	✘	✘	✘
12HSA*	Calcium	✘	✘	✘	✘	●	●	✘		✘
	Lithium	●	◉	●	✘	●	●	✘	✘	

*12HSA = 12-Hydroxystearic Acid

CROSS ROLLER / BALL RAILS & ASSEMBLIES

SLIDE RAIL SYSTEM



Nook slide rail system used as a steady rest for a large diameter CNC machine.



FEATURES

- Slide System..... 164
- Linear Shafting..... 165

BEARING DESIGN CONSIDERATIONS

- Friction..... 166
- Lubrication..... 166
- Load Rating 166-167
- Installation 167

SLIDE SYSTEM DESIGN CONSIDERATIONS

- Load Bearing Calculations 169
- Acceleration..... 169
- Deflection..... 169
- Application Examples 170

CARRIAGE MOUNTING PLATES..... 172

SERIES 100 SLIDE

- 111** Single Shaft - Unsupported System 173
- 112** Double Shaft - Unsupported System 174
- 113** Double Shaft - Unsupported System - Carriage 175
- 121** Single Shaft - End Supported System 176
- 122** Double Shaft - End Supported System..... 177
- 123** Double Shaft - End Supported System - Carriage 178
- 131** Single Shaft - Fully Supported System 179
- 132** Double Shaft - Fully Supported System..... 180
- 133** Double Shaft - Fully Supported System - Carriage 181

SERIES 200 SLIDE

- Overview..... 182
- Reference Number System..... 183
- 212** Double Shaft - End Supported System - Ball Screw Assembly and Carriage..... 184
- 252** Double Shaft - Fully Supported System - Ball Screw Assembly and Carriage..... 185

SLIDE SYSTEM FEATURES

A Nook Series slide assembly is truly a “System” not simply a “Component”. The matched components used in Nook Slides result in better system performance. When Nook Slides Systems are used as sub-assemblies, setup and alignment time is reduced. Nook Slide Systems are easier to specify and to order.

Precision carriage plates supplied with Series 100 and 200 help prevent misaligned shafts and bearings. Aluminum carriage plates include threaded steel inserts at key mounting locations. Protective, non-corrosive finish on all exposed non-wear components. Nook Slide Systems have been engineered by Nook Industries for use in the following applications:

- Product packaging
- Electronics manufacturing
- Food processing
- Machine tool equipment
- Component assembly
- Material handling
- Converting processes
- Container manufacturing
- Medical equipment
- Textile industry
- Automated test equipment

Contact Nook Industries to discuss special requirements.

Modifications include:

- Special screws (ground thread, precision rolled with preloaded nuts, high lead screws, metric lead screws, etc.)
- Protective boots in a variety of materials (neoprene, metallic, etc.)
- Special motor mounts with Servos motors, steppers motors and drives
- Custom carriage machining

SERIES 100 SLIDE SYSTEM

Nook Series 100 slide systems are pre-assembled and ready to mount. Series 100 slides consist of combinations of Nook Linear Ball Bearing Pillow Blocks, HG shafting, carriage plates and shaft supports. Aluminum carriage plates include threaded steel inserts at key mounting locations. All exposed non-wearing components have a protective, corrosion resistant finish.

SERIES 200 SLIDE SYSTEM

Nook Series 200 slide systems are assembled slides which include:

- Linear Bearing Pillow Blocks
- Integrated end supports
- HG linear shafts
- Carriage Plate
- Nook Ball Screw Assembly or Acme Screw Assembly

Many options are available for these slide systems. Different screw styles and leads, protective boots, special motor mounts and custom carriage plate machining is available. Contact Nook Industries for assistance.

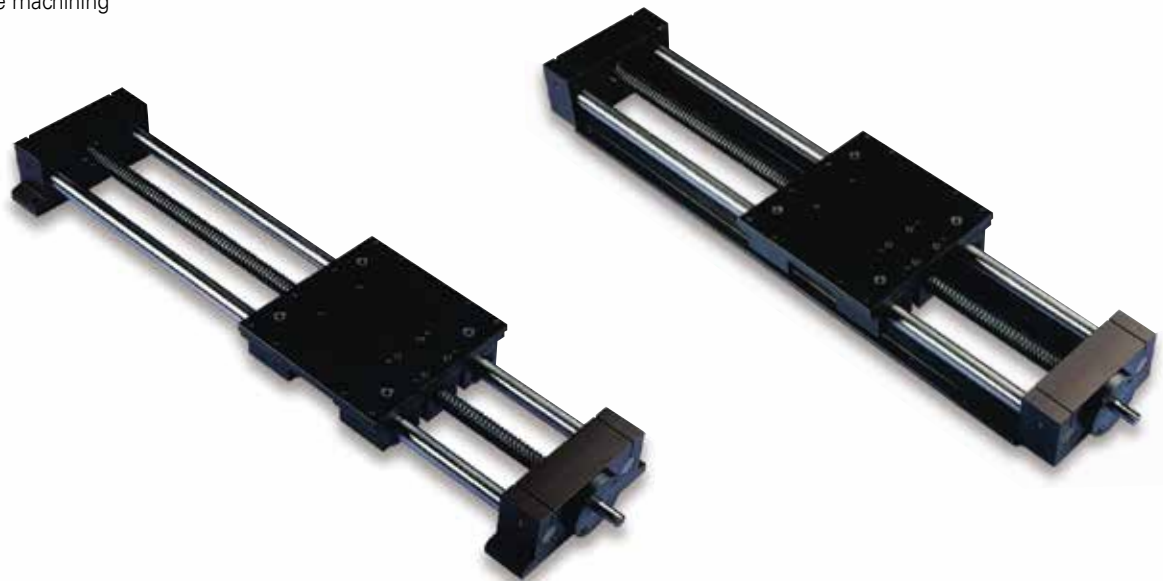

LINEAR SHAFTING FEATURES

SURFACE FINISH

Nook HG shafting is centerless ground to a consistently smooth surface finish of 14 micro inches rms or less. Excellent surface finish and hardness maximize the efficiency and life of linear bearings.



End



Horizontal

STRAIGHTNESS

Nook HG shafts are straight within 0.002 of an inch per foot cumulative when shipped from the factory. Handling or machining of shafting can cause the material to bend.

PRE-DRILLED & TAPPED HOLES

Nook HG alloy shafting is stocked with radial holes drilled and tapped to accept a continuous shaft support rail. Continuous support prevents shaft deflection when used to support heavy loads or for long travel lengths. Radial holes can be supplied in stainless steel shafts from 1/2" to 2" diameter.



PRECISION END MACHINING

Nook HG shafting can be supplied pre-machined to application requirements. Send a detailed sketch or blueprint for a prompt quotation. See page 200-201 for descriptions of machining offered by Nook Industries. Templates for machining are available on our website: www.nookindustries.com.

LENGTH TOLERANCE

Nook HG shafting cut to your specified length will have a standard length tolerance of $+1/32$ " up to 2" diameter and $\pm 1/16$ " above 2" diameter. Closer tolerances are available for an additional charge. Non-precision chamfered ends are standard on all cut shafting.

SHAFT SUPPORTS

Aluminum support components for end mounting or continuously supporting Nook HG shafting are available for inch sizes 1/2" to 2".

SELF-ALIGNING PILLOW BLOCKS



Nook Pillow Blocks simplify mounting of Nook Linear Bearings. They are available with Excel™ Bearings to fit shafts from 1/4 to 2 inch and 10 to 50mm. Nook Pillow Blocks provide the precision bearing bores necessary for linear bearing installation.

MOUNTING TOLERANCES

The Nook Pillow Block mounting surface to center line dimension is held to ± 0.001 inch. Bearings will self-align up to $\pm 1/2^\circ$.

MATERIALS

All Nook Pillow Blocks are manufactured from precision machined, thick walled, extruded aluminum.

PILLOW BLOCK SEALS

Nook Pillow Blocks are supplied complete with lip seals. The sealed pillow block keeps lubricant in and dirt and debris out, resulting in smoother operation and longer bearing life.

BEARING DESIGN CONSIDERATIONS

APPLICATION VARIABLES

To determine the best linear bearing product or system for your application it is necessary to know:

- Amount of load
- How the load is applied
- Length of stroke

COEFFICIENT OF FRICTION

Nook linear bearings exhibit an extremely low coefficient of friction ranging from 0.0008 to 0.0035. Coefficients of static and rolling friction are used to estimate the force required to overcome frictional resistance. The formulas for determining static and rolling frictional resistance are:

STATIC FRICTION:

$$F_s = L \times f_s$$

ROLLING FRICTION:

$$F_d = L \times f_d$$

Where:

F_s = Static frictional resistance (lbs)

F_d = dynamic frictional resistance (lbs)

L = applied radial load (pounds)

f_s = coefficient of static friction

f_d = coefficient of rolling friction

The tables show the coefficients of friction for Nook Linear Bearings operating on hardened and ground shafts of recommended diameters. (See FIG. 4)

There are other variables that affect the dynamic frictional resistance of linear bearings. These variables include:

Lubrication Dry linear bearings exhibit the lowest coefficient of friction. Friction values for lubricated bearings are higher due to the presence of lubricant surface tension.

Seals Non-linear seal drag occurs because of the geometry and the materials used in the bearing seals.

Contamination Foreign particles restrict free rolling of the bearing balls and will contribute to an increase in dynamic frictional resistance.

LUBRICATION

A lubricant formulated for rolling friction should be used with Nook Linear Bearings. In applications where operating speeds are low and loads are light, Nook linear bearings can be used without lubrication at a reduced life. However, to protect the highly polished bearing surfaces from corrosion and wear, a lubricant is recommended.

Where linear speeds are high, a light oil should be used and provision for re-lubrication should be made to avoid operating the bearings dry. For typical applications, a medium to heavy oil has good surface adhesion and affords greater bearing protection. Linear Bearings of 2" diameter and above may use high pressure lithium grease such as Shell Alvania #2 for moderate speed applications. Lubricants containing additives such as molydisulfide or graphite should not be used.

Nook Linear Lube LBL-1 liquid is a good, all purpose lubricant for use with linear bearings. See page 198 for more information.

MAXIMUM AND NORMAL LOAD RATINGS

The required design life, the shaft hardness, and a bearing dynamic load rating affect the load that can be applied to a Nook linear bearing. Two dynamic load ratings are given for each bearing size based on the rotational orientation of the bearing.

Normal Load Rating

Normal load rating is used in applications where the orientation of the ball tracks relative to the load cannot be controlled. The Normal load rating is based on a load imposed directly over a single ball track. The Normal load rating shown in the specification tables is slightly greater than would be mathematically calculated based on one track loading because it assumes that the load is shared to some degree by one or more of the adjacent ball tracks.

FIG. 4

COEFFICIENTS OF STATIC FRICTION (f_s)				
Type of Bearing Lubrication	Load In % Of Rated Load			
	100%	75%	50%	25%
Any	.0024	.0026	.0029	.0035

COEFFICIENTS OF ROLLING FRICTION (f_d)				
Type of Bearing Lubrication	Load In % Of Rated Load			
	100%	75%	50%	25%
None	.0008	.0009	.0013	.0018
Oil	.0012	.0013	.0016	.0021
Grease	.0013	.0015	.0019	.0026

BEARING DESIGN CONSIDERATIONS

MAXIMUM LOAD RATING

The Maximum load rating assumes that the load is applied midway between two ball tracks as illustrated below. In this orientation the load is distributed over the maximum number of bearing balls. (See FIG. 5)

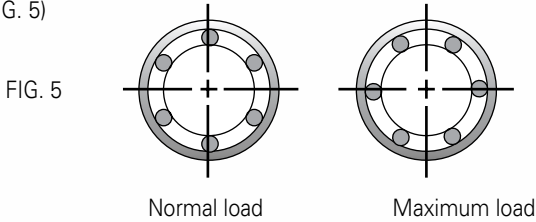

LOAD LIFE DETERMINATION

The Normal and Maximum load ratings are based on a Rc 60 shaft hardness and a travel life of two million inches. For linear bearing system operating at less than full rated load, the Load-Life Curve may be used to determine the travel life expectancy. (See FIG. 7)

SHAFT HARDNESS

If shafting other than standard alloy Nook HG shafting is used, the Shaft Hardness Curve establishes a shaft hardness correction factor, Rh. When calculating the equivalent load, this factor compensates for the effect of hardness. (See FIG. 6)

FIG. 6

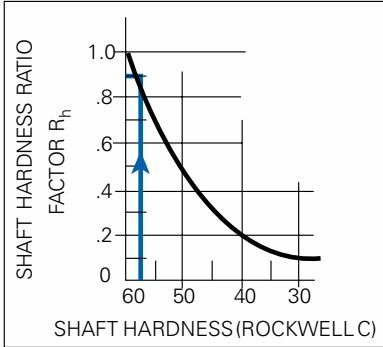
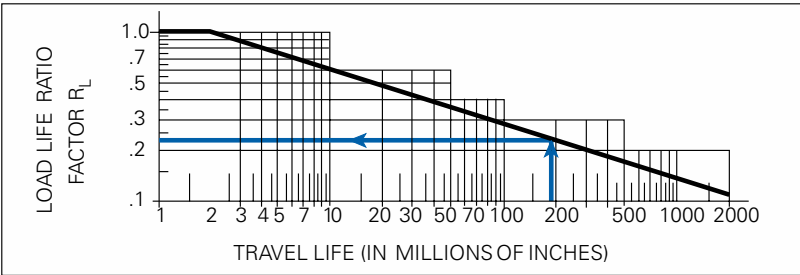

FIG. 7



EQUIVALENT LOAD

An equivalent load value can be calculated when sizing linear bearings for applications at conditions other than maximum rating.

Equivalent Load Formula:

$$L_e = L_a / (R_L \times R_h)$$

Where:

L_e = Dynamic Equivalent Load (The minimum bearing capacity to meet design life requirements)

L_a = Applied Load (Actual Load)

R_L = Load Life Ratio Factor (from chart)

R_h = Shaft Hardness Ratio Factor (from chart)

BEARING INSTALLATION

In most installations, Nook linear ball bearings are designed to slip-fit into the housing bore and be secured by one of the following means:

- Between an internal housing shoulder and a threaded cap.
- Between external retaining rings.
- Between internal snap rings in the bore of the housing.

The bore diameter required to maintain recommended bearing/ shaft clearance is given in the Excel™ linear bearing information section. The bore does not affect clearance between an LBB bearing and a shaft. (See FIG. 8)

FIG. 8

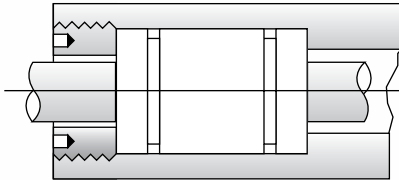

Between an internal housing shoulder and a threaded cap.

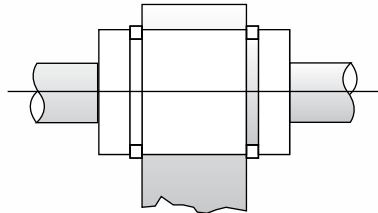

Between external retaining rings.

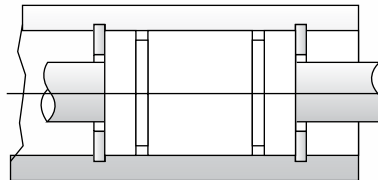

Between internal snap rings in the bore of the housing.

SLIDE SYSTEM DESIGN CONSIDERATIONS

ASSEMBLY EXCESSIVE FIT

Oversized shaft diameters or misalignment between the installed bearings can cause preload between the shaft and the bearing. Preload conditions should be corrected before operating the bearing. If, in an assembled unit, the shaft can freely rotate relative to the bearing, then the fit is at the maximum or less.

SYSTEM DESIGN CONSIDERATIONS

Single Or Double Shaft Systems

The majority of applications require double shaft systems in order to restrain the load in two planes. Single shaft systems may be used for hanging or vertical loads where rotation of the bearing around the shaft is allowable.

FULLY SUPPORTED OR UNSUPPORTED SHAFTS

Fully supported systems are used to eliminate shaft deflection. Full shaft supports must be attached to a machined mounting base. Open style bearings used with this system are sensitive to load orientation.

End-supported systems are generally used to span a gap or where some deflection is allowable. This system uses closed-style bearings that achieve higher load capacities. The shaft must be selected so that deflection does not exceed self-alignment capability of the bearing.

LINEAR BEARING PILLOW BLOCKS

Two bearings must be used to support a load on a shaft. Single blocks allow for custom spacing and wider load bearing stances. Twin pillow blocks have a compact, one-piece design.

BEARING/SHAFT SIZE

For fully supported systems the bearing size needed for the application is determined by the load and life requirements. For end-supported systems, both the bearing diameter that meets load and life requirements and the shaft diameter that results in an allowable deflection must be determined. The correct choice of shaft/bearing diameter is the larger of the two.

LOAD CONDITIONS

Linear systems require at least three bearings to define the plane of motion. It is necessary to identify and understand which of following load conditions affect the application:

- Centered Loads
- Offset loads
- Side Loads
- Vertical Loads
- Gravity Effects
- Reaction Forces (i.e., cutting tool reaction)
- Dynamic Loading (acceleration, deceleration and inertial loads)

CARRIAGE PLATES

Carriage plates are designed in two styles for linear system packages.

Carriage 1 is designed for two pairs of single bearing blocks.

Carriage 2 is designed for two twin bearing blocks and has a shorter over all length.

SLIDE SYSTEM DESIGN CONSIDERATIONS

Apply the actual load to the appropriate load condition in the figure below to calculate the resulting bearing loads. (See FIG. 10)

FIG. 10

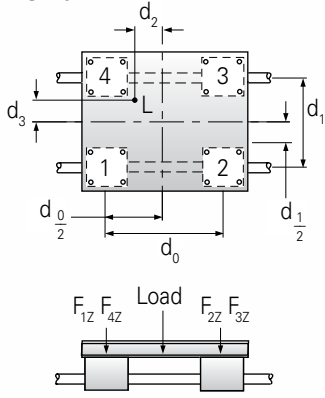

Load Centered

$$F_{1z} = \frac{L}{4} + \left(\frac{L}{2} \times \frac{d_2}{d_0}\right) - \left(\frac{L}{2} \times \frac{d_3}{d_1}\right)$$

$$F_{2z} = \frac{L}{4} - \left(\frac{L}{2} \times \frac{d_2}{d_0}\right) - \left(\frac{L}{2} \times \frac{d_3}{d_1}\right)$$

$$F_{3z} = \frac{L}{4} - \left(\frac{L}{2} \times \frac{d_2}{d_0}\right) + \left(\frac{L}{2} \times \frac{d_3}{d_1}\right)$$

$$F_{4z} = \frac{L}{4} + \left(\frac{L}{2} \times \frac{d_2}{d_0}\right) + \left(\frac{L}{2} \times \frac{d_3}{d_1}\right)$$

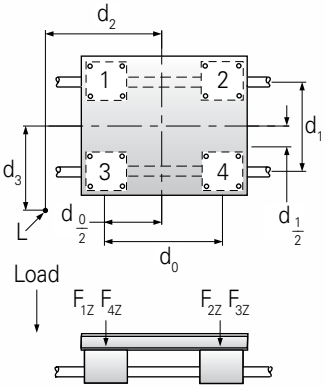

Load Offset

$$F_{1z} = \frac{L}{4} + \left(\frac{L}{2} \times \frac{d_2}{d_0}\right) - \left(\frac{L}{2} \times \frac{d_3}{d_1}\right)$$

$$F_{2z} = \frac{L}{4} - \left(\frac{L}{2} \times \frac{d_2}{d_0}\right) - \left(\frac{L}{2} \times \frac{d_3}{d_1}\right)$$

$$F_{3z} = \frac{L}{4} - \left(\frac{L}{2} \times \frac{d_2}{d_0}\right) + \left(\frac{L}{2} \times \frac{d_3}{d_1}\right)$$

$$F_{4z} = \frac{L}{4} + \left(\frac{L}{2} \times \frac{d_2}{d_0}\right) + \left(\frac{L}{2} \times \frac{d_3}{d_1}\right)$$

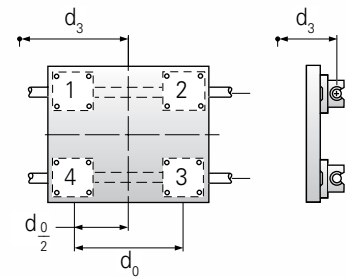

Side Mounted

$$F_{1y} = F_{4y} = \left(\frac{L}{2} \times \frac{d_2}{d_0}\right)$$

$$F_{1z} = F_{4z} = \frac{L}{4} + \left(\frac{L}{2} \times \frac{d_2}{d_0}\right)$$

$$F_{2z} = F_{3z} = \frac{L}{4} - \left(\frac{L}{2} \times \frac{d_2}{d_0}\right)$$

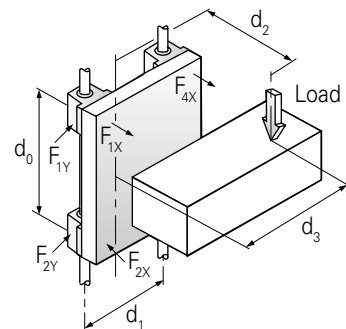

Vertical Mounted

$$F_{1x} = F_{4x} = \left(\frac{L}{2} \times \frac{d_2}{d_0}\right)$$

$$F_{1y} = F_{4y} = \frac{L}{4} + \left(\frac{L}{2} \times \frac{d_2}{d_0}\right)$$

$$F_{1x} + F_{4y} = F_{2x} + F_{3x}$$

$$F_{1y} + F_{4y} = F_{2y} + F_{3y}$$

ACCELERATION FORCES

Use the equation in the following figure to determine the additional forces developed due to acceleration. If impact or impulse loads are anticipated, these forces must also be considered when selecting the appropriate bearing size. (See FIG. 11)

AT THE TIME OF ACCELERATION AND SLOW DOWN FIG. 11

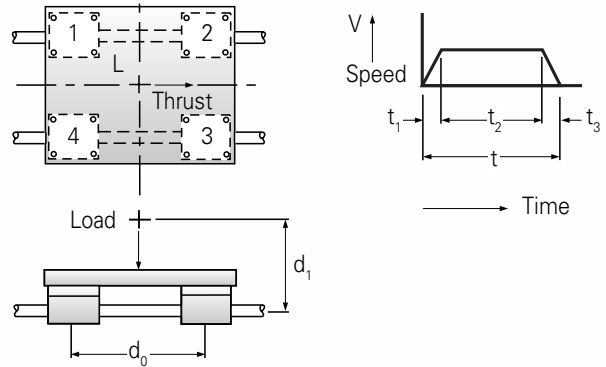

At the time acceleration starts:

$$F_1 = F_3 = \frac{L}{4} \left(1 + \frac{2V_1 \times d_1}{g \times t_1 \times d_0}\right)$$

$$F_2 = F_4 = \frac{L}{4} \left(1 - \frac{2V_1 \times d_1}{g \times t_1 \times d_0}\right)$$

At the time it slows down:

$$F_1 = F_4 = \frac{L}{4} \left(1 - \frac{2V_1 \times d_1}{g \times t_1 \times d_0}\right)$$

$$F_2 = F_3 = \frac{L}{4} \left(1 + \frac{2V_1 \times d_1}{g \times t_1 \times d_0}\right)$$

At constant velocity:

$$F_1 = F_2 = F_3 = F_4 = \frac{1}{4} L$$

Gravitational acceleration:

$$g = 384 \text{ in./sec}^2 = 9.8 \text{ m/sec}^2$$

SHAFT DEFLECTION

Shaft deflection should be considered when choosing the proper bearing and shaft diameter for end-supported systems. Deflection is directly related to the diameter of the shaft, the unsupported length of the shaft, and the type of shaft end mounting that is used.

Typical Shaft End Mounting. (See FIG. 12)

“Simple” - the end allows some of the shaft deflection slope through the fastening point.

“Fixed” - the ends are constrained from deflection.

NOTE: Fixed end mounting can be accomplished by capturing the shaft end with a length of engagement equal to or greater than 1½ times the shaft diameter.

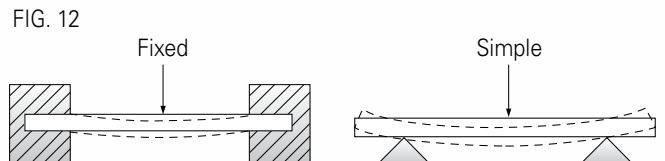

FIG. 12

SYSTEM DESIGN CONSIDERATIONS

DEFLECTION CALCULATION

Use the formula:

$$D = N \times W \times L^3$$

Where:

N = value from FIG. 13

W = load in pounds

L = length (in inches) of unsupported shaft section

FIG. 13

"N" VALUE FOR NOOK SHAFTS		
Shaft Diameter (in)	Simple	Fixed
¼	3620×10^{-9}	905×10^{-9}
⅜	715×10^{-9}	179×10^{-9}
½	226×10^{-9}	56.6×10^{-9}
¾	44.7×10^{-9}	11.2×10^{-9}
1	14.1×10^{-9}	3.54×10^{-9}
1½	2.79×10^{-9}	$.698 \times 10^{-9}$
2	0.866×10^{-9}	$.0220 \times 10^{-9}$
3	0.168×10^{-9}	$.432 \times 10^{-10}$
4	0.052×10^{-9}	$.136 \times 10^{-10}$

APPLICATION EXAMPLES

Application #1 – Packaging Line

An appliance manufacturer needs to move products in boxes so that they can be presented to a transfer conveyor after final assembly.

Specifications:

- The boxes weigh 200 pounds
- The unit reciprocates 8 times per minute
- 4.5 inch stroke
- 365 days per year, ten year design life
- Slightly corrosive environment

What is the proper size Excel™ Bearing which will satisfy this application?

Analysis:

Configuration: There is enough space available for four linear bearings. The system will use stainless steel shafting with a hardness of Rc 55. The load can be centered between four standard Excel™ linear bearings.

Travel Life:

4.5 in. / stroke × 8 strokes / min. × 60 min. / hr ×
24 hrs. / day × 365 days / year × 10 years = 189,000,000 inches.

CALCULATE MISALIGNMENT ANGLE

Nook linear bearings allow for ½ degree misalignment. To determine the amount of misalignment due to shaft deflection use the formula:

$$\theta = \sin^{-1} (D/L)$$

Where:

θ = angle in degrees

D = shaft deflection

L = length (in inches) of unsupported shaft section.

If misalignment is greater than ½ degree, then:

- Reduce the Length of the shaft
- Use a larger shaft diameter

Shaft Hardness Ratio Factor (R_h):

For Nook HG Stainless shafting with a hardness of Rc 55, $R_h = .70$

Applied Load (L_a):

Per bearing, $L_a = 200/4 = 50$ lb

Equivalent Load (L_e):

Substituting in the load formula and solving for
 $L_e = 50 / (.22 \times .70) = 325$ lb

Selection:

From the Excel™ Bearing load tables, the smallest bearing which exceeds this load rating is the ¾ inch bearing. However, if the application is such that the bearing could be oriented for maximum capacity, then the ⅝ inch bearing could be used.

The Parts List Is:

4 XLEC12 Excel™ Linear bearings
2 Nook HG Stainless shafting
9.25 inch minimum length
2 Nook NSB-12 End supports

Load-Life Ratio Factor (RL):

Based on the computed travel life and the load-life curve $R_L = .22$.

Application #2 – Scanner Positioning

A vision system scanner is mounted to the center of the carriage of a vertically mounted slide system. The customer wants to use one inch open pillow blocks to guarantee a long life.

Specifications:

- Scanner weight is 100 pounds
- The center of gravity is offset 4 inches from the carriage plate
- The adjustment distance is 36 inches
- Minimal deflection desired
- Hand adjustment with future automation planned
- A travel life of 10 million inches is desired

Analysis:

Configuration: A standard system with carriage plate and fully supported shafts will assure minimal deflection.

Load Per Bearing:

The load is centered and offset four inches. Use the equations from the load condition figure “Vertically Mounted” to determine the worst case force through a bearing. The distance from the load to the center line of the shaft (d2) is $4 + 1.187$ or 5.187 inches. The bearing spacing (d0) is set by the carriage plate; $d0 = 7$ inches. Based on a design factor of 2, the load per bearing is 74 pounds. This is far below the rated value of a one inch open bearing.

NOTE: When using open-style bearings, if the direction of loading force is through the opening of the bearing, it is necessary to de-rate the bearing capacity by 50%.

Selection:

Nook Series 133 consisting of a double shaft fully supported system with Carriage 1 and four (4) single bearing blocks.

The Parts List is:

133-16-L36

LOAD / LIFE

Lines indicate limiting load for given shaft size

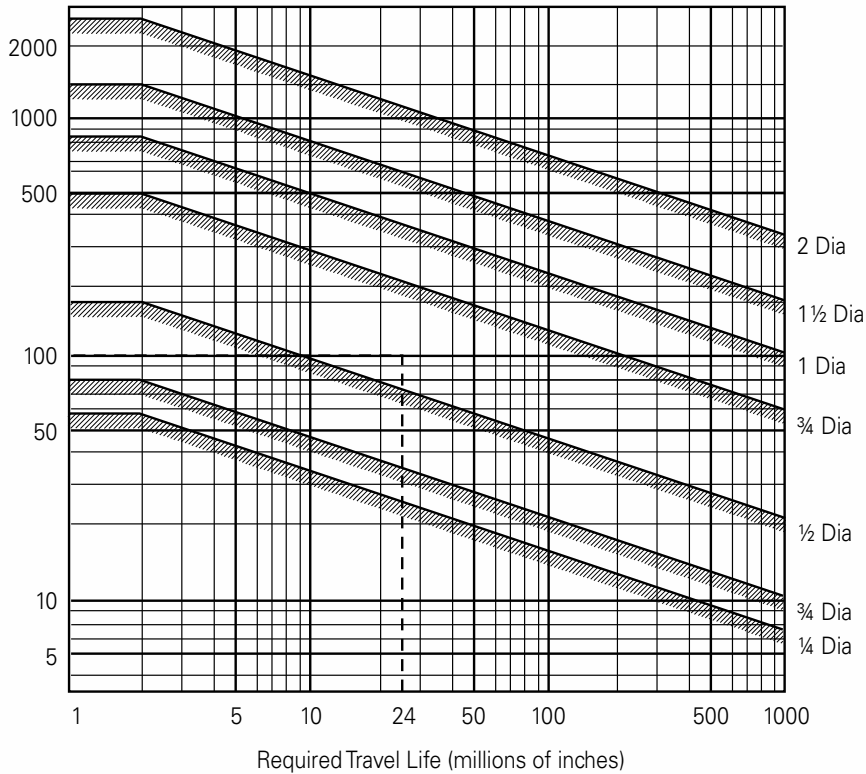

SLIDE RAIL SYSTEMS

CARRIAGE MOUNTING PLATES

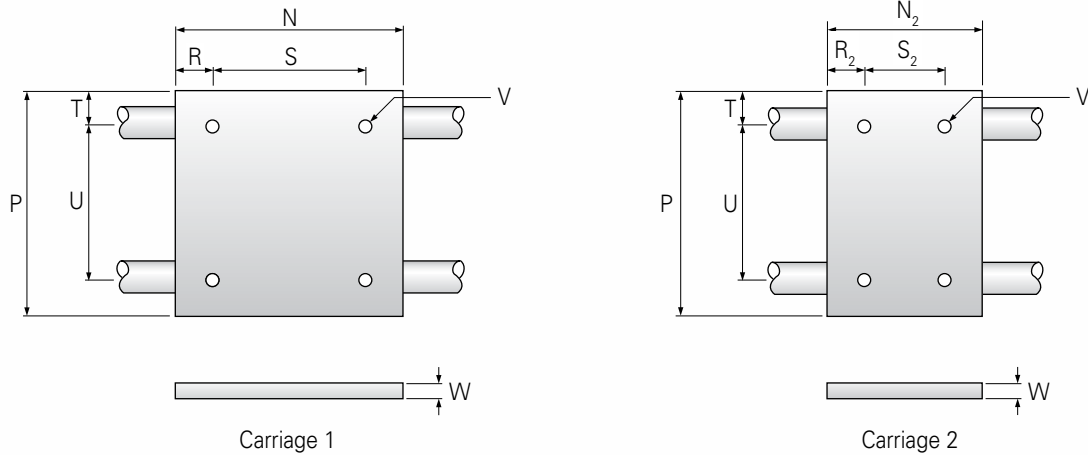

CARRIAGE MOUNTING PLATES

NOMINAL SHAFT DIA. (in)	CARRIAGE 1 (in)			CARRIAGE 1 & 2 (in)					CARRIAGE 2 (in)		
	N	R	S	P	T	U	V	W	N ₂	R ₂	S ₂
½	5.5	.50	4.5	5.5	1.125	3.25	¼-20	.375	3.5	.50	2.5
¾	7.5	.75	6.0	7.5	1.500	4.50	⅝-18	.50	4.5	.75	3.0
1	9.0	1.00	7.0	9.0	1.750	5.50	¾-16	.50	6.0	1.00	4.0
1½	13.0	1.50	10.0	13.0	2.500	8.00	½-13	.75	9.0	1.50	6.0

Material = Aluminum Alloy Black Anodized



Nook linear shafts used to guide a bottle filler application.

111 SLIDE SINGLE SHAFT UNSUPPORTED SYSTEM

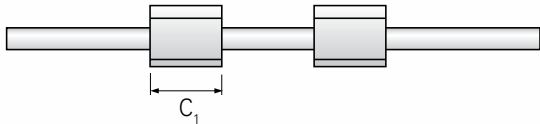
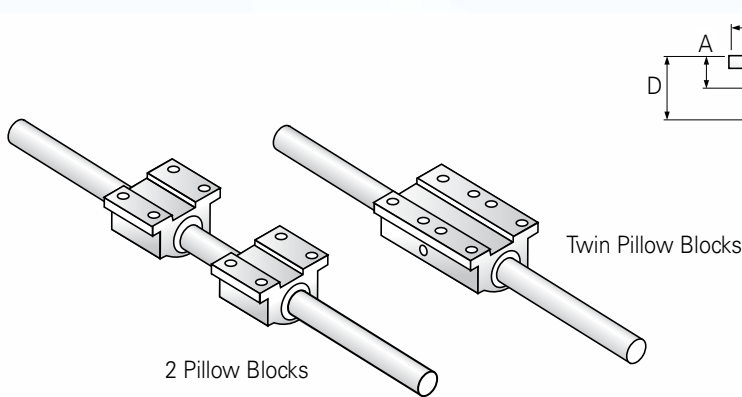

Single Shaft Unsupported with 2 Pillow Blocks

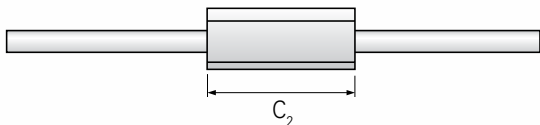

Single Shaft Unsupported with Twin Pillow Blocks

HOW TO ORDER

State appropriate part number and length: **111-06-SXX** XX=Shaft length
Part No.

SINGLE SHAFT UNSUPPORTED WITH 2 PILLOW BLOCKS

PART NUMBER	NOMINAL SHAFT DIA. (in)	LOAD (lbf)* Max/Block	A±.001	DIMENSIONS (in)			PILLOW BLOCK▼
				B	C_1	D	
111-06-SXX	3/8	68	0.500	1.75	1.31	0.94	XEP-06
111-08-SXX	1/2	175	0.687	2.00	1.69	1.25	XEP-08
111-12-SXX	3/4	406	0.937	2.75	2.06	1.75	XEP-12
111-16-SXX	1	725	1.187	3.25	2.81	2.19	XEP-16
111-24-SXX	1 1/2	1,376	1.750	4.75	4.00	3.25	XEP-24

▼ See page 193 for details.

* Based on horizontal load, equally distributed to each bearing with a travel life of 2 million inches.

SINGLE SHAFT UNSUPPORTED WITH TWIN PILLOW BLOCKS

PART NUMBER	NOMINAL SHAFT DIA. (in)	LOAD (lbf)* Max/Block	A±.001	DIMENSIONS (in)			PILLOW BLOCK■
				B	C_2	D	
111-06-TXX	3/8	136	0.500	1.75	2.75	0.94	TEP-06
111-08-TXX	1/2	350	0.687	2.00	3.50	1.25	TEP-08
111-12-TXX	3/4	812	0.937	2.75	4.50	1.75	TEP-12
111-16-TXX	1	1,450	1.187	3.25	6.00	2.19	TEP-16
111-24-TXX	1 1/2	2,752	1.750	4.75	9.00	3.25	TEP-24

■ See page 194 for details.

* Based on horizontal load, equally distributed to each bearing with a travel life of 2 million inches.

112 SLIDE DOUBLE SHAFT UNSUPPORTED SYSTEM

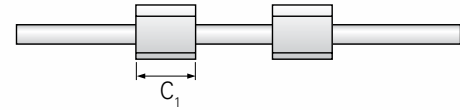
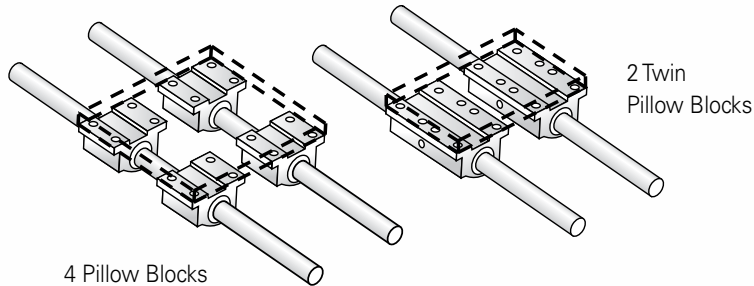
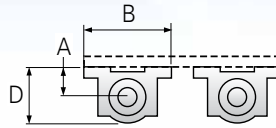

Double Shaft Unsupported with 4 Pillow Blocks

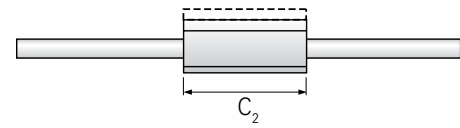

Double Shaft Unsupported with 2 Twin Pillow Blocks

HOW TO ORDER

State appropriate part number and length: **112-06-SXX** XX=Shaft length
Part No.

DOUBLE SHAFT UNSUPPORTED WITH 4 PILLOW BLOCKS

PART NUMBER	NOMINAL SHAFT DIA. (in)	LOAD (lbf)*		A±.001	DIMENSIONS (in)			PILLOW BLOCK ▼
		Max/System	Max/Block		B	C ₁	D	
112-06-SXX	3/8	272	68	0.500	1.75	1.31	0.94	XEP-06
112-08-SXX	1/2	700	175	0.687	2.00	1.69	1.25	XEP-08
112-12-SXX	3/4	1,624	406	0.937	2.75	2.06	1.75	XEP-12
112-16-SXX	1	2,900	725	1.187	3.25	2.81	2.19	XEP-16
112-24-SXX	1 1/2	5,504	1,376	1.750	4.75	4.00	3.25	XEP-24

▼ See page 193 for details.

* Based on horizontal load, equally distributed to each bearing with a travel life of 2 million inches.

DOUBLE SHAFT UNSUPPORTED WITH 2 TWIN PILLOW BLOCKS

PART NUMBER	NOMINAL SHAFT DIA. (in)	LOAD (lbf)*		A±.001	DIMENSIONS (in)			PILLOW BLOCK ■
		Max/System	Max/Block		B ₁	C ₂	D	
112-06-TXX	3/8	272	136	0.500	1.75	2.75	0.94	TEP-06
112-08-TXX	1/2	700	350	0.687	2.00	3.50	1.25	TEP-08
112-12-TXX	3/4	1,624	812	0.937	2.75	4.50	1.75	TEP-12
112-16-TXX	1	2,900	1,450	1.187	3.25	6.00	2.19	TEP-16
112-24-TXX	1 1/2	5,504	2,752	1.750	4.75	9.00	3.25	TEP-24

■ See page 194 for details.

* Based on horizontal load, equally distributed to each bearing with a travel life of 2 million inches.

113 SLIDE DOUBLE SHAFT UNSUPPORTED SYSTEM CARRIAGE

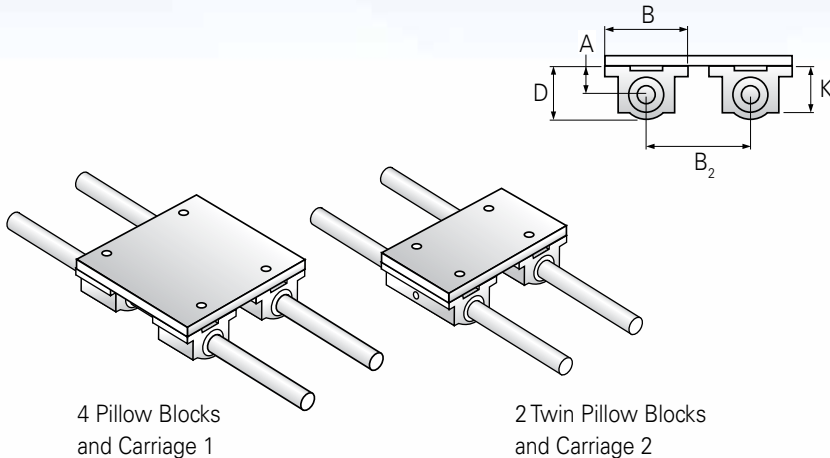

4 Pillow Blocks
and Carriage 1

2 Twin Pillow Blocks
and Carriage 2

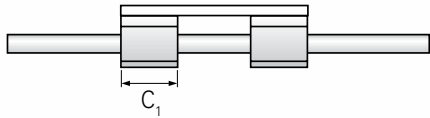

Double Shaft Unsupported
with 4 Pillow Blocks and Carriage 1

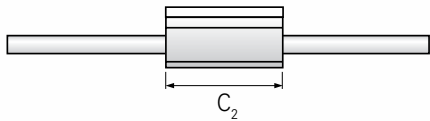

Double Shaft Unsupported
with 2 Twin Pillow Blocks and Carriage 2

HOW TO ORDER

State appropriate part number and length: **113-08-SXX** XX=Shaft length
Part No.

DOUBLE SHAFT UNSUPPORTED WITH 4 PILLOW BLOCKS AND CARRIAGE 1

PART NUMBER	NOMINAL SHAFT DIA. (in)	LOAD (lbf)* Max/System	A±.001	DIMENSIONS (in)				PILLOW BLOCK▼
				B	B ₂	C ₁	D	
113-08-SXX	½	700	0.687	2.00	3.25	1.69	1.25	XEP-08
113-12-SXX	¾	1,624	0.937	2.75	4.50	2.06	1.75	XEP-12
113-16-SXX	1	2,900	1.187	3.25	5.50	2.81	2.19	XEP-16
113-24-SXX	1½	5,504	1.750	4.75	8.00	4.00	3.25	XEP-24

▼ See page 193 for details.

* Based on horizontal load, equally distributed to each bearing with a travel life of 2 million inches.

DOUBLE SHAFT UNSUPPORTED WITH 2 TWIN PILLOW BLOCKS AND CARRIAGE 2

PART NUMBER	NOMINAL SHAFT DIA. (in)	LOAD (lbf)* Max/System	A±.001	DIMENSIONS (in)				PILLOW BLOCK■
				B	B ₂	C ₂	D	
113-08-TXX	½	700	0.687	2.00	3.25	3.50	1.25	TEP-08
113-12-TXX	¾	1,624	0.937	2.75	4.50	4.50	1.75	TEP-12
113-16-TXX	1	2,900	1.187	3.25	5.50	6.00	2.19	TEP-16
113-24-TXX	1½	5,504	1.750	4.75	8.00	9.00	3.25	TEP-24

■ See page 194 for details.

* Based on horizontal load, equally distributed to each bearing with a travel life of 2 million inches.

121 SLIDE SINGLE SHAFT END SUPPORTED SYSTEM

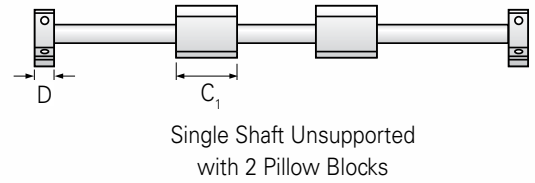
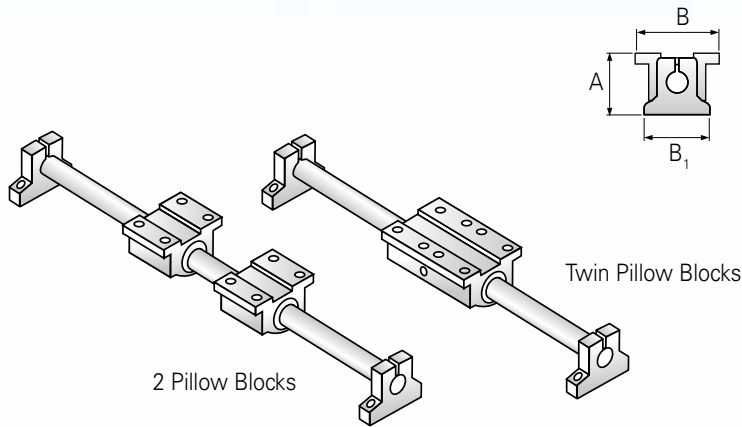

Single Shaft Unsupported with 2 Pillow Blocks

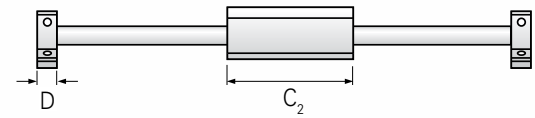

Single Shaft Unsupported with Twin Pillow Blocks

HOW TO ORDER

State appropriate part number and length: **121-06-SXX** XX=Shaft length
Part No.

SINGLE SHAFT END SUPPORTED WITH 2 PILLOW BLOCKS

PART NUMBER	NOMINAL SHAFT DIA. (in)	LOAD (lbf)* Max/Block	DIMENSIONS (in)					PILLOW BLOCK ▼	END SUPPORT ◆
			A±.003	B	B ₁	C ₁	D		
121-06-SXX	3/8	68	1.250	1.75	1.63	1.31	0.56	XEP-06	NSB-6
121-08-SXX	1/2	175	1.687	2.00	2.00	1.69	0.63	XEP-08	NSB-8
121-12-SXX	3/4	406	2.187	2.75	2.75	2.06	0.75	XEP-12	NSB-12
121-16-SXX	1	725	2.687	3.25	3.25	2.81	1.00	XEP-16	NSB-16
121-24-SXX	1 1/2	1,376	3.750	4.75	4.75	4.00	1.25	XEP-24	NSB-24

▼ See page 193 for details. ◆ See page 203 for details.

* Based on horizontal load, equally distributed to each bearing with a travel life of 2 million inches.

SINGLE SHAFT END SUPPORTED WITH TWIN PILLOW BLOCKS

PART NUMBER	NOMINAL SHAFT DIA. (in)	LOAD (lbf)* Max/Block	DIMENSIONS (in)					MAX. STROKE LENGTH (in)	PILLOW BLOCK ■	END SUPPORT ◆
			A±.003	B	B ₁	C ₂	D			
121-06-TXX	3/8	136	1.250	1.75	1.63	2.75	0.56	L-(3.88)	TEP-06	NSB-6
121-08-TXX	1/2	350	1.687	2.00	2.00	3.50	0.63	L-(4.75)	TEP-08	NSB-8
121-12-TXX	3/4	812	2.187	2.75	2.75	4.50	0.75	L-(6.00)	TEP-12	NSB-12
121-16-TXX	1	1,450	2.687	3.25	3.25	6.00	1.00	L-(8.00)	TEP-16	NSB-16
121-24-TXX	1 1/2	2,752	3.750	4.75	4.75	9.00	1.25	L-(11.50)	TEP-24	NSB-24

■ See page 194 for details. ◆ See page 203 for details.

* Based on horizontal load, equally distributed to each bearing with a travel life of 2 million inches.

122 SLIDE DOUBLE SHAFT END SUPPORTED SYSTEM

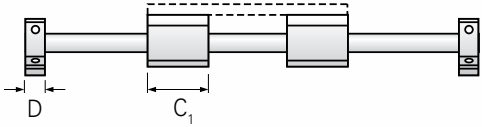
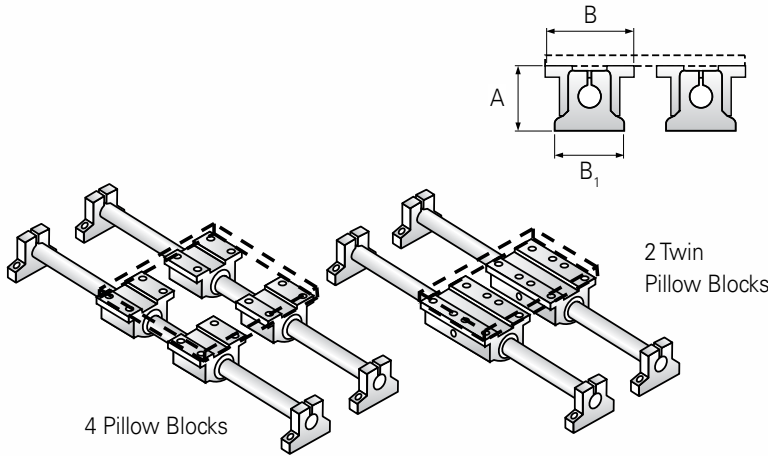

Double Shaft Unsupported
with 4 Pillow Blocks

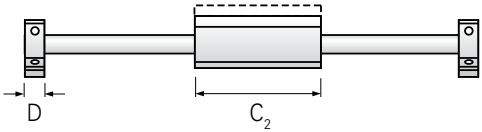

Double Shaft Unsupported
with 2 Twin Pillow Blocks

HOW TO ORDER

State appropriate part number and length: **122-06-SXX** XX=Shaft length
Part No.

DOUBLE SHAFT END SUPPORTED WITH 4 PILLOW BLOCKS

PART NUMBER	NOMINAL SHAFT DIA. (in)	LOAD (lbf)*		A±.003	DIMENSIONS (in)				PILLOW BLOCK ▼	END SUPPORT ◆
		Max/System	Max/Block		B	B ₁	C ₁	D		
122-06-SXX	3/8	272	68	1.250	1.75	1.63	1.31	0.56	XEP-06	NSB-6
122-08-SXX	1/2	700	175	1.687	2.00	2.00	1.69	0.63	XEP-08	NSB-8
122-12-SXX	3/4	1,624	406	2.187	2.75	2.75	2.06	0.75	XEP-12	NSB-12
122-16-SXX	1	2,900	725	2.687	3.25	3.25	2.81	1.00	XEP-16	NSB-16
122-24-SXX	1 1/2	5,504	1,376	3.750	4.75	4.75	4.00	1.25	XEP-24	NSB-24

▼ See page 193 for details. ◆ See page 203 for details.
* Based on horizontal load, equally distributed to each bearing with a travel life of 2 million inches.

DOUBLE SHAFT END SUPPORTED WITH 2 TWIN PILLOW BLOCKS

PART NUMBER	NOMINAL SHAFT DIA. (in)	LOAD (lbf)*		A±.003	DIMENSIONS (in)				MAX. STROKE LENGTH (in)	PILLOW BLOCK ■	END SUPPORT ◆
		Max/System	Max/Block		B	B ₁	C ₂	D			
122-06-TXX	3/8	272	136	0.500	1.75	1.63	2.75	0.56	L-(3.88)	TEP-06	NSB-6
122-08-TXX	1/2	700	350	0.687	2.00	2.00	3.50	0.63	L-(4.75)	TEP-08	NSB-8
122-12-TXX	3/4	1,624	812	0.937	2.75	2.75	4.50	0.75	L-(6.00)	TEP-12	NSB-12
122-16-TXX	1	2,900	1,450	1.187	3.25	3.25	6.00	1.00	L-(8.00)	TEP-16	NSB-16
122-24-TXX	1 1/2	5,504	2,752	1.750	4.75	4.75	9.00	1.25	L-(11.50)	TEP-24	NSB-24

■ See page 194 for details. ◆ See page 203 for details.
* Based on horizontal load, equally distributed to each bearing with a travel life of 2 million inches.

123 SLIDE **DOUBLE SHAFT** END SUPPORTED SYSTEM CARRIAGE

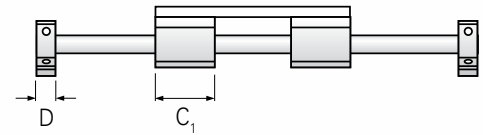
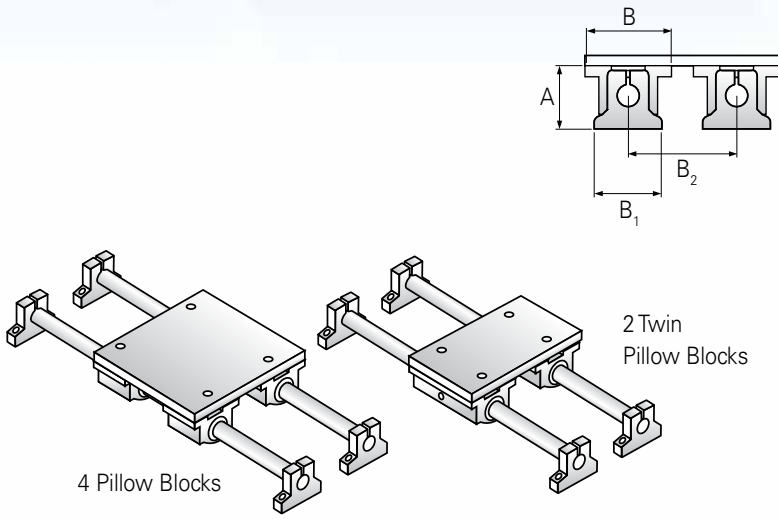

Double Shaft End Supported
with 4 Pillow Blocks and Carriage 1

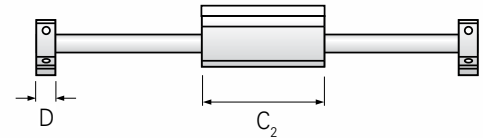

Double Shaft End Supported
with 2 Twin Pillow Blocks and Carriage 2

HOW TO ORDER

State appropriate part number and length: **123-08-SXX** XX=Shaft length
Part No.

DOUBLE SHAFT FULLY SUPPORTED WITH 4 PILLOW BLOCKS

PART NUMBER	NOMINAL SHAFT DIA. (in)	LOAD (lbf)* Max/System	DIMENSIONS (in)					PILLOW BLOCK▼	END SUPPORT◆
			A±.003	B ₂	B ₁	C ₁	D		
123-08-SXX	½	700	1.687	3.25	2.00	1.69	0.63	XEP-08	NSB-8
123-12-SXX	¾	1,624	2.187	4.50	2.75	2.06	0.75	XEP-12	NSB-12
123-16-SXX	1	2,900	2.687	5.50	3.25	2.81	1.00	XEP-16	NSB-16
123-24-SXX	1½	5,504	3.750	8.00	4.75	4.00	1.25	XEP-24	NSB-24

▼ See page 193 for details. ◆ See page 203 for details.

* Based on horizontal load, equally distributed to each bearing with a travel life of 2 million inches.

DOUBLE SHAFT FULLY SUPPORTED WITH 2 TWIN PILLOW BLOCKS

PART NUMBER	NOMINAL SHAFT DIA. (in)	LOAD (lbf)* Max/System	DIMENSIONS (in)					MAX. STROKE LENGTH (in)	PILLOW BLOCK■	END SUPPORT◆
			A±.003	B ₂	B ₁	C ₂	D			
123-08-TXX	½	700	1.687	3.25	2.00	3.50	0.63	L-(4.75)	TEP-08	NSB-8
123-12-TXX	¾	1,624	2.187	4.50	2.75	4.50	0.75	L-(6.00)	TEP-12	NSB-12
123-16-TXX	1	2,900	2.687	5.50	3.25	6.00	1.00	L-(8.00)	TEP-16	NSB-16
123-24-TXX	1½	5,504	3.750	8.00	4.75	9.00	1.25	L-(11.50)	TEP-24	NSB-24

■ See page 194 for details. ◆ See page 203 for details.

* Based on horizontal load, equally distributed to each bearing with a travel life of 2 million inches.

131 SLIDE SINGLE SHAFT FULLY SUPPORTED SYSTEM

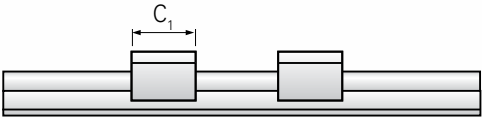
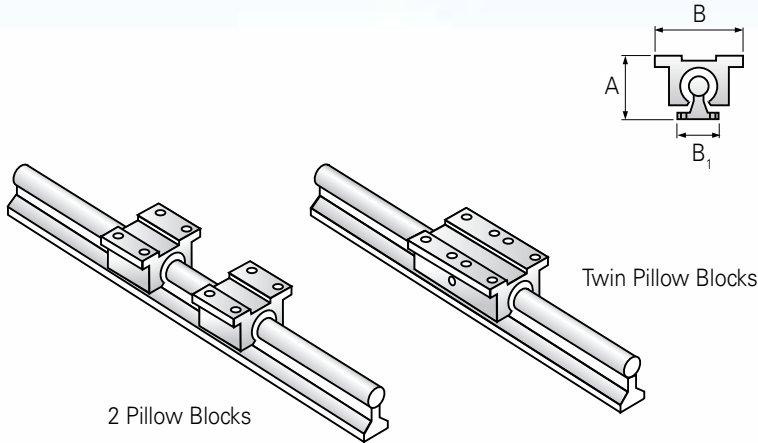

Single Shaft Fully Supported
with 2 Pillow Blocks

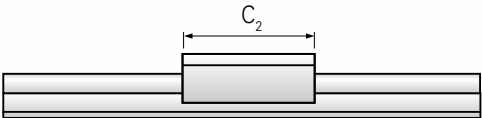

Single Shaft Fully Supported
with Twin Pillow Blocks

HOW TO ORDER

State appropriate part number and length: **131-08-SXX** XX=Shaft length
Part No.

SINGLE SHAFT FULLY SUPPORTED WITH 2 PILLOW BLOCKS

PART NUMBER	NOMINAL SHAFT DIA. (in)	LOAD (lbf)* Max/Block	A±.003	DIMENSIONS (in)			PILLOW BLOCK▼
				B	C ₁	B ₁	
131-08-SXX	½	152	1.812	2.00	1.69	1.50	XEP-08-OPN
131-12-SXX	¾	398	2.437	2.75	2.06	1.75	XEP-12-OPN
131-16-SXX	1	711	2.937	3.25	2.81	2.13	XEP-16-OPN
131-24-SXX	1½	1,346	4.250	4.75	4.00	3.00	XEP-24-OPN

▼ See page 193 for details.

* Based on horizontal load, equally distributed to each bearing with a travel life of 2 million inches.

SINGLE SHAFT FULLY SUPPORTED WITH TWIN PILLOW BLOCKS

PART NUMBER	NOMINAL SHAFT DIA. (in)	LOAD (lbf)* Max/Block	A±.003	DIMENSIONS (in)			PILLOW BLOCK■
				B	B ₁	C ₂	
131-08-TXX	½	304	1.812	2.00	3.50	1.50	TEP-08-OPN
131-12-TXX	¾	796	2.437	2.75	4.50	1.75	TEP-12-OPN
131-16-TXX	1	1,422	2.937	3.25	6.00	2.13	TEP-16-OPN
131-24-TXX	1½	2,692	4.250	4.75	9.00	3.00	TEP-24-OPN

■ See page 194 for details.

* Based on horizontal load, equally distributed to each bearing with a travel life of 2 million inches.

132 SLIDE DOUBLE SHAFT FULLY SUPPORTED SYSTEM

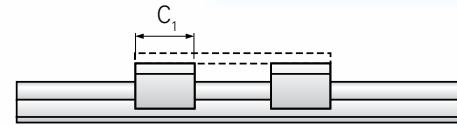
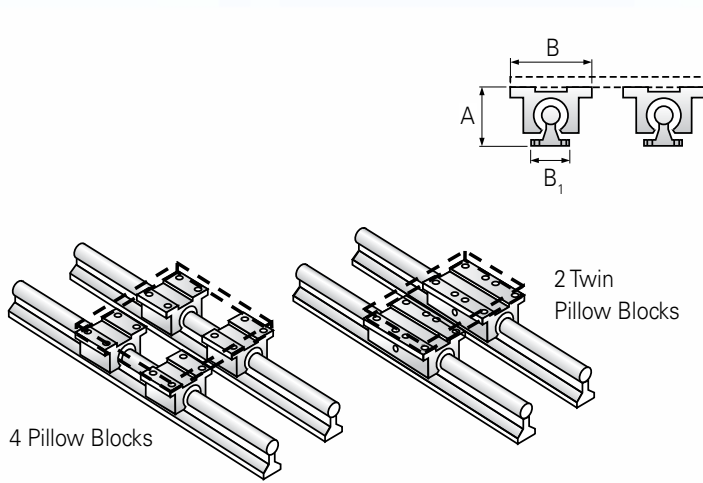

Double Shaft Fully Supported with 4 Pillow Blocks

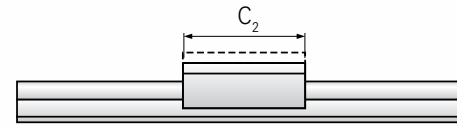

Double Shaft Fully Supported with 2 Twin Pillow Blocks

HOW TO ORDER

State appropriate part number and length: **132-08-SXX** XX=Shaft length
Part No.

DOUBLE SHAFT FULLY SUPPORTED WITH 4 PILLOW BLOCKS

PART NUMBER	NOMINAL SHAFT DIA. (in)	LOAD (lbf)*		A±.003	DIMENSIONS (in)			PILLOW BLOCK▼
		Max/System	Max/Block		B	B ₁	C ₁	
132-08-SXX	½	608	152	1.812	2.00	1.50	1.69	XEP-08-OPN
132-12-SXX	¾	1,584	398	2.437	2.75	1.75	2.06	XEP-12-OPN
132-16-SXX	1	2,844	711	2.937	3.25	2.13	2.81	XEP-16-OPN
132-24-SXX	1½	5,384	1,346	4.250	4.75	3.00	4.00	XEP-24-OPN

▼ See page 193 for details.

* Based on horizontal load, equally distributed to each bearing with a travel life of 2 million inches.

DOUBLE SHAFT FULLY SUPPORTED WITH 2 TWIN PILLOW BLOCKS

PART NUMBER	NOMINAL SHAFT DIA. (in)	LOAD (lbf)*		A±.003	DIMENSIONS (in)			PILLOW BLOCK■
		Max/System	Max/Block		B	B ₁	C ₂	
132-08-TXX	½	608	304	1.812	2.00	1.50	3.50	TEP-08-OPN
132-12-TXX	¾	1,584	796	2.437	2.75	1.75	4.50	TEP-12-OPN
132-16-TXX	1	2,844	1,422	2.937	3.25	2.13	6.00	TEP-16-OPN
132-24-TXX	1½	5,384	2,692	4.250	4.75	3.00	9.00	TEP-24-OPN

■ See page 194 for details.

* Based on horizontal load, equally distributed to each bearing with a travel life of 2 million inches.

133 SLIDE **DOUBLE SHAFT**
FULLY SUPPORTED SYSTEM
CARRIAGE

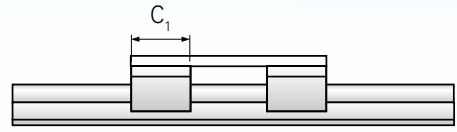
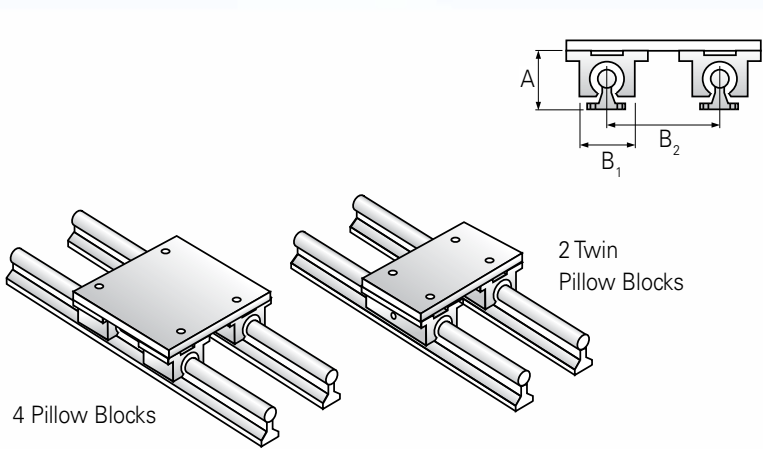

Double Shaft Fully Supported
with 4 Pillow Blocks and Carriage 1

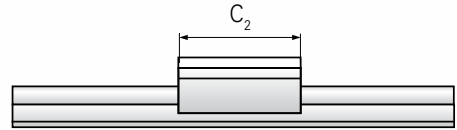

Double Shaft Fully Supported
with 2 Twin Pillow Blocks and Carriage 2

HOW TO ORDER

State appropriate part number and length: **133-08-SXX** XX=Shaft length
Part No.

DOUBLE SHAFT FULLY SUPPORTED WITH 4 PILLOW BLOCKS AND CARRIAGE 1

PART NUMBER	NOMINAL SHAFT DIA. (in)	LOAD (lbf)* Max/System	DIMENSIONS (in) A±.003	DIMENSIONS (in)			PILLOW BLOCK ▼
				B ₁	B ₂	C ₁	
133-08-SXX	½	608	1.812	1.50	3.25	1.50	XEP-08-OPN
133-12-SXX	¾	1,584	2.437	1.75	4.50	1.88	XEP-12-OPN
133-16-SXX	1	2,844	2.937	2.13	5.50	2.63	XEP-16-OPN
133-24-SXX	1½	5,384	4.250	3.00	8.00	3.75	XEP-24-OPN

▼ See page 193 for details.

* Based on horizontal load, equally distributed to each bearing with a travel life of 2 million inches.

DOUBLE SHAFT FULLY SUPPORTED WITH 2 TWIN PILLOW BLOCKS AND CARRIAGE 2

PART NUMBER	NOMINAL SHAFT DIA. (in)	LOAD (lbf)* Max/System	DIMENSIONS (in) A±.003	DIMENSIONS (in)			PILLOW BLOCK ■
				B ₁	B ₂	C ₂	
133-08-TXX	½	608	1.812	1.50	3.25	3.50	TEP-08-OPN
133-12-TXX	¾	1,584	2.437	1.75	4.50	4.50	TEP-12-OPN
133-16-TXX	1	2,844	2.937	2.13	5.50	6.00	TEP-16-OPN
133-24-TXX	1½	5,384	4.250	3.00	8.00	9.00	TEP-24-OPN

■ See page 194 for details.

* Based on horizontal load, equally distributed to each bearing with a travel life of 2 million inches.

SERIES 200 OVERVIEW



All Nook Precision Slides can be supplied with Stepper Motors, Servo Motor Drives and controllers. Contact factory engineers.

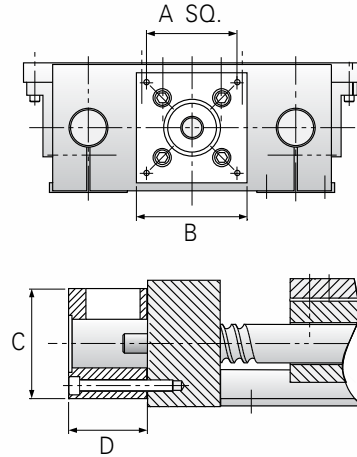

BENEFITS

- Adaptable to any drive system
- Flexible design
- Use where end supported systems are needed
- Pre-aligned, easy installation

NOOK SLIDE SYSTEM MOTOR ADAPTORS

Allows for direct connection of a motor to a slide. Custom configurations are available, contact Nook Industries.

- Coupling is included
- Available for Series 212 & 252
- Aluminum construction

NOOK SLIDE SYSTEM BELLOWS BOOTS

Protects slide components from contaminants. Custom configurations are available, contact Nook Industries

- Available for Series 212 and 252
- PVC coated nylon
- Boot is fastened to the end blocks and carriage plate with hook and loop fasteners

MOTOR ADAPTORS FOR 212

Slide Part No.	Frame Size	Dimension (in)			
		A	B	C	D
-08	23	1.86	2.25	2.25	1.65
-12	23	1.86	2.25	2.25	1.85
-16	34	2.74	3.25	3.25	2.75
-24	42	3.50	4.25	4.25	2.98

MOTOR ADAPTORS FOR MM SLIDE

Slide Part No.	Frame Size	Dimension (in)			
		A	B	C	D
012 - 06	23	47.25	572	572	40.9

Contact Nook Industries for additional sizes.

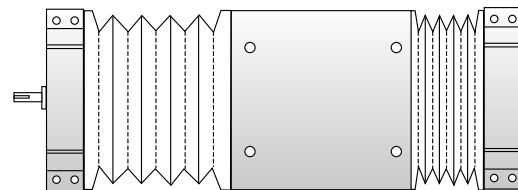

EXAMPLE 212-08-LXX with 24" Travel:

$$L = (\text{Travel} + 8.5") + \text{Ret. Boot} + \text{Ret. Boot}$$

$$39.7" = (24" + 8.5") + 3.6" + 3.6"$$

(See pages 184 and 185 for 212 and 252 Series min "L" dimension.)

NOTE: Travel must be adjusted to accommodate retracted boot.

Calculation per each boot is:

$$\text{Retracted Boot} = (\text{Travel} \times .14") + .25$$

SERIES 200 REFERENCE NUMBER SYSTEM

212 - **12** - **L 24** / **0750-0200 S R T** / **A34 / S**

MODEL

212 = Double Shaft End Supported System with Screw
252 = Double Shaft Fully Supported System with Screw

SHAFT DIAMETER

Diameter of the shaft in sixteenth of an inch
8 = 1/2 inch 16 = 1 inch
12 = 3/4 inch 24 = 1 1/2 inch

OVERALL LENGTH

OAL Including end blocks, are inches preceded by an "L". See pages 184 and 185 for Series 212 and 252. OAL for 012 is in mm.

NOTE: See description on the following pages for actual travel distance and standard lengths.

SCREW SPECIFICATION

Screw Size is matched to the diameter of the shaft. Select either an Acme or Ball Screw Part Number.

SHAFT DIA.	ACME SCREW PART #	BALL SCREW PART #
8 (1/2")	1/2-1	0500-0200 SRT 0500-0500 SRT
	1/2-2	
	1/2-5	
	1/2-10	
12 (3/4")	3/4-10	0750-0200 SRT 0750-0500 SRT
16 (1")	1-1	1000-0250 SRT 1000-0500 SRT 1000-1000 SRT
	1-10	
24 (1 1/2")	1 1/2-2	1500-0250 SRT 1500-0500 SRT 1500-1000 SRT 1500-1875 SRT
	1 1/2-2 2/3	
	1 1/2-4	
	1-1/2-5	
	1 1/2-10	

MOTOR ADAPTERS

A23 = 23 Frame for the 8 (1/2") and 12 (3/4") Slide A42 = 42 Frame for the 24 (1 1/2") Slide 00 = No motor adapter
A34 = 34 Frame for the 16 (1") A56 = 56 Frame for 24 Slide

MODIFIER LIST

Always S or M

S = Standard, no additional description or modification required
M = Modified, additional description required
B = Boot, the "L" dimension must be increased by .1" times travel in order to accommodate the retracted boot

SLIDE RAIL SYSTEMS

212 SLIDE **DOUBLE SHAFT** END SUPPORTED SYSTEM BALL SCREW ASSEMBLY AND CARRIAGE

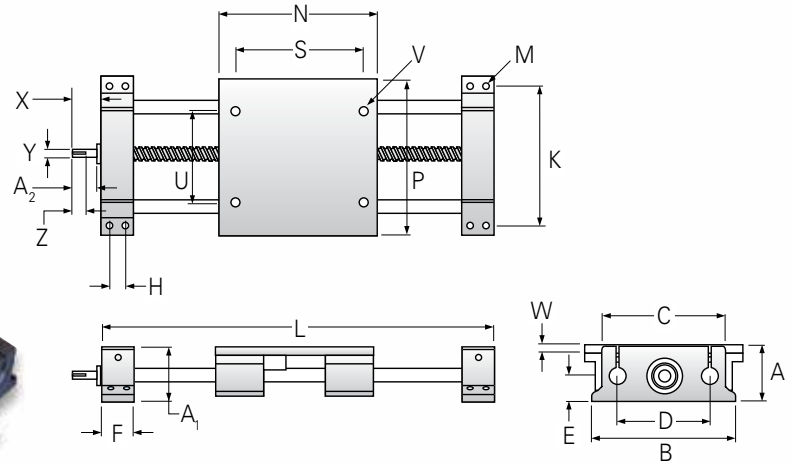
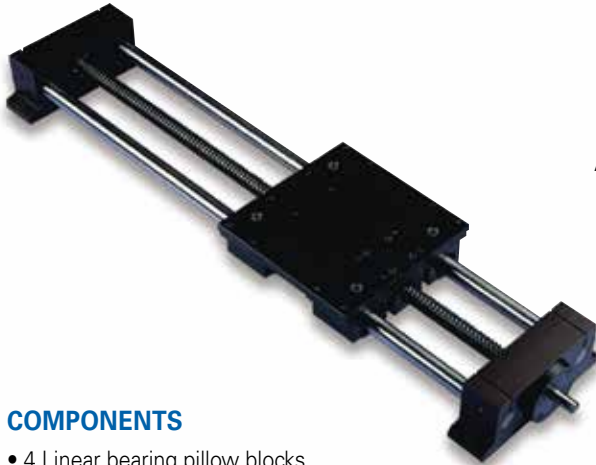

COMPONENTS

- 4 Linear bearing pillow blocks
- 2 Integrated end supports
- 2 HG linear shafts
- 1 carriage
- 1 ball screw assembly

DOUBLE SHAFT END SUPPORT SYSTEM WITH BALL SCREW ASSEMBLY AND CARRIAGE

PART NO.	NOMINAL SHAFT DIA.	LOAD (lbf)* Max System	BALL SCREW DIA.	DIMENSIONS (in)										MIN. "L" DIMENSION (in)	
				A ±.003	A ₁	B	C	D	E	F	H ±.010	K ±.010	M Bolt Hole		
212 - 08 - LXX	½	700	.50	2.187	2.38	5.30	4.25	3.25	1.125	1.50	.75	4.80	#8	.19	Travel+8.50
212 - 12 - LXX	¾	1,624	.75	2.937	2.88	7.20	6.00	4.50	1.500	2.00	1.00	6.70	#10	.22	Travel+11.50
212 - 16 - LXX	1	2,900	1.00	3.437	3.45	8.75	7.25	5.50	1.750	2.20	1.20	8.00	¼	.28	Travel+13.40
212 - 24 - LXX	1½	5,504	1.50	5.000	4.97	13.00	10.75	8.00	2.500	2.80	1.50	12.00	⅝	.34	Travel+18.60

* Based on horizontal load, equally distributed to each bearing with a travel life of 2 million inches.

MOUNTING CARRIAGE TOP FOR 212 & 252

PART NO.	DIMENSIONS (in)					
	N	P	S	U	V	W
2X2 - 08 - LXX	5.50	5.5	4.50	3.25	¼ - 20	.38
2X2 - 12 - LXX	7.50	7.50	6.0	4.50	⅝ - 18	.50
2X2 - 16 - LXX	9.00	9.00	7.0	5.50	⅞ - 16	.50
2X2 - 24 - LXX	13.00	13.00	10.00	8.00	½ - 13	.75

SCREW & SHAFT EXTENSION FOR 212 & 252

PART NO.	DIMENSIONS (in)				
	Screw Size	X	Y	Z	A ₂
2X2 - 08 - LXX	0500 - 0500 SRT	1.00	.250	.51 × .095	.665
2X2 - 12 - LXX	0750 - 0200 SRT	1.50	.500	.81 × .140	1.02
2X2 - 16 - LXX	1000 - 1000 SRT	1.74	.625	1.03 × .188	1.26
2X2 - 24 - LXX	1500 - 1000 SRT	2.32	.750	1.14 × .188	1.657

252 SLIDE DOUBLE SHAFT FULLY SUPPORTED SYSTEM WITH END SUPPORTS BALL SCREW ASSEMBLY AND CARRIAGE

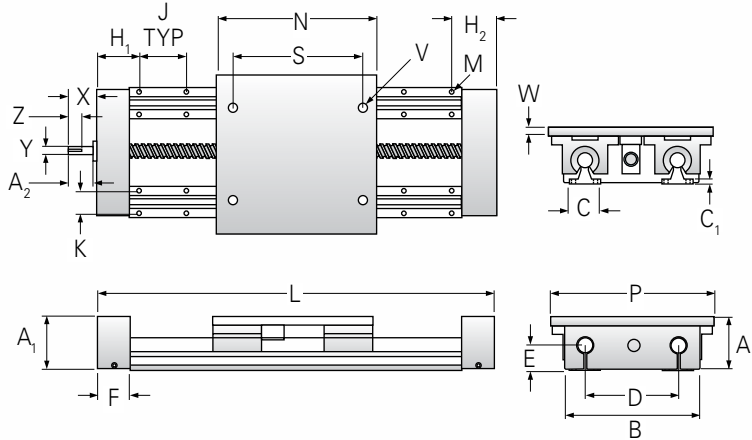

COMPONENTS

- 4 Linear bearing pillow blocks (open)
- 2 Integrated end supports
- 2 HG linear shafts
- 1 carriage, 1 ball screw assembly
- 2 shaft support rails

DOUBLE SHAFT END SUPPORT SYSTEM WITH BALL SCREW ASSEMBLY AND CARRIAGE

PART NO.	NOM SHAFT DIA.	LOAD (lbf)* Max System	BALL SCREW DIA.	DIMENSIONS (in)												MIN. "L" DIMENSION (in)
				A ±.003	A ₁	B	D	E	F	C	C ₁	H ±.010	K ±.010	M Bolt Hole		
252-08-LXX	½	700	.50-.50	2.187	2.13	4.25	3.25	1.125	1.50	1.50	.187	4.00	1.00	#6	.17	Travel+8.50
252-12-LXX	¾	2,040	.75-.20	2.937	2.75	6.00	4.50	1.500	2.00	1.75	.250	6.00	1.25	#10	.22	Travel+11.50
252-16-LXX	1	3,320	1.00-1.00	3.437	3.25	7.25	5.50	1.750	2.20	2.13	.250	6.00	1.50	¼	.28	Travel+13.40
252-24-LXX	1½	5,384	1.50-1.00	5.000	4.88	10.75	8.00	2.500	2.80	3.00	3.00	8.00	2.25	¾	.41	Travel+18.60

* Based on horizontal load, equally distributed to each bearing with a travel life of 2 million inches.
H1 = H2 Custom H dimensions now available.

DOUBLE SHAFT SYSTEM WITH STANDARD LENGTH FOR 212 & 252

PART NO.	18"	24"	30"	32"	36"	40"	42"	48"	54"	56"	60"	64"	66"	72"
2X2 - 08 - LXX	•	•	•		•		•	•						
2X2 - 12 - LXX	•	•	•		•		•	•						
2X2 - 16 - LXX		•	•		•		•	•	•		•		•	•
2X2 - 24 - LXX		•		•		•		•		•		•		•

PTPS PRECISION PROFILE RAIL SLIDE

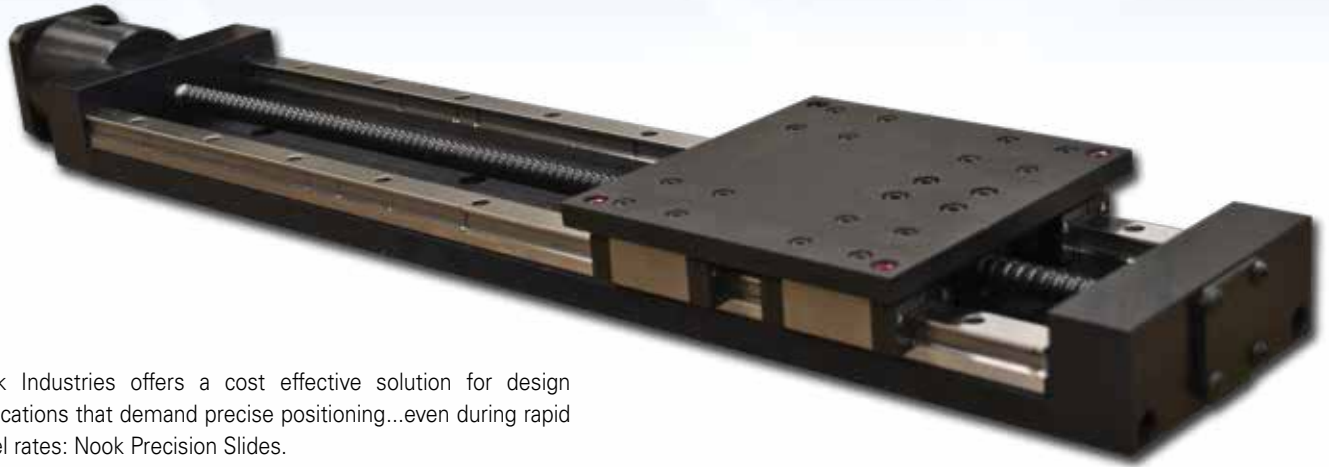

Nook Industries offers a cost effective solution for design applications that demand precise positioning...even during rapid travel rates: Nook Precision Slides.

These high performance machine slides are precision-engineered for machine tool, robotic, food processing, metalworking and precise material handling applications.

The ball screw driven precision slides are rigidly constructed and compact-designed to hold load capacities. Nook Precision Slides incorporate low friction, smooth profile rails for super accurate linear travel with zero-backlash.

The high load carrying capacity of the Nook Precision Slide allows it to dramatically outperform standard bushing-type ball bearing slides.

Nook Precision Slides are conveniently available in lengths up to 72 inches with many different ball screw configurations possible, including precision ground ball screws. This versatility allows for custom tailored speed and accuracy capabilities to meet your most demanding design requirements.

- Accurate position
- High speed
- Heavy loads
- System friendly
- Rigid construction

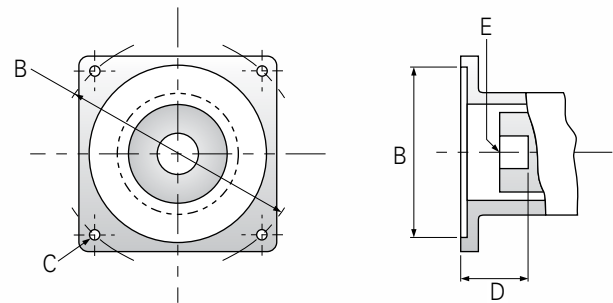
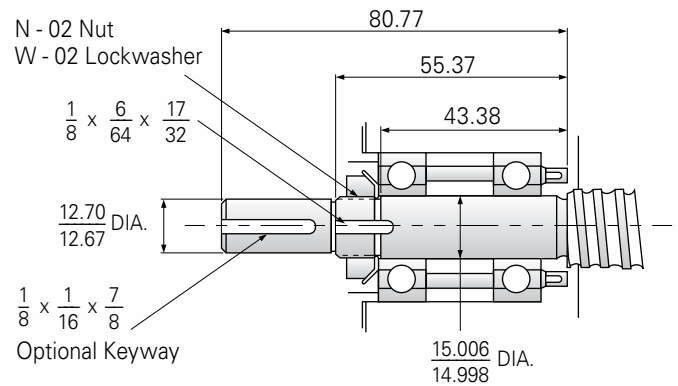

STANDARD MOTOR MOUNTINGS (mm)

Part No.	A Pilot Dia.	B B.C.D.	C Mtg Holes	D Shaft Extension	E Bore
NEMA 23	38.1	66.67	4# 10-32	19.5	6.34
NEMA 34	73	98.42	4# 10-32	30	9.53
NEMA 42	55.52	76.2	3 @ .218	31.75	9.53

Note: For special motor mounting, consult Nook engineering.

LINEAR GUIDANCE SLIDE RAIL SYSTEMS

PART NO.	STROKE	LENGTH (mm)			NO. OF MTG. HOLES	MAX SCREW RPM			
		A	B	C		20 x 5	20 x 20	0750-0200	0750-0200*
PTPS - 6	140	300	375	443	6	3,810	3,810	4,000	4,000
PTPS - 10	260	420	495	563	8	3,810	3,810	4,000	4,000
PT PS - 15	380	540	615	683	10	3,810	3,810	4,000	4,000
PTPS - 20	500	660	735	803	12	3,810	3,810	4,000	4,000
PTPS - 24	622	780	855	923	14	3,810	3,842	3,899	3,555
PTPS - 30	743	900	975	1,043	16	2,896	2,615	2,929	2,670
PTPS - 34	857	1,020	1,095	1,163	18	2,254	2,036	2,280	2,079
PTPS - 39	978	1,140	1,215	1,283	20	1,805	1,630	1,825	1,644

- Max Normal Load Dynamic = 2,400 lb
 - If Axial Load Exceeds 2,000 LBS, Consult Nook Engineering.
- * Precision Ground Thread

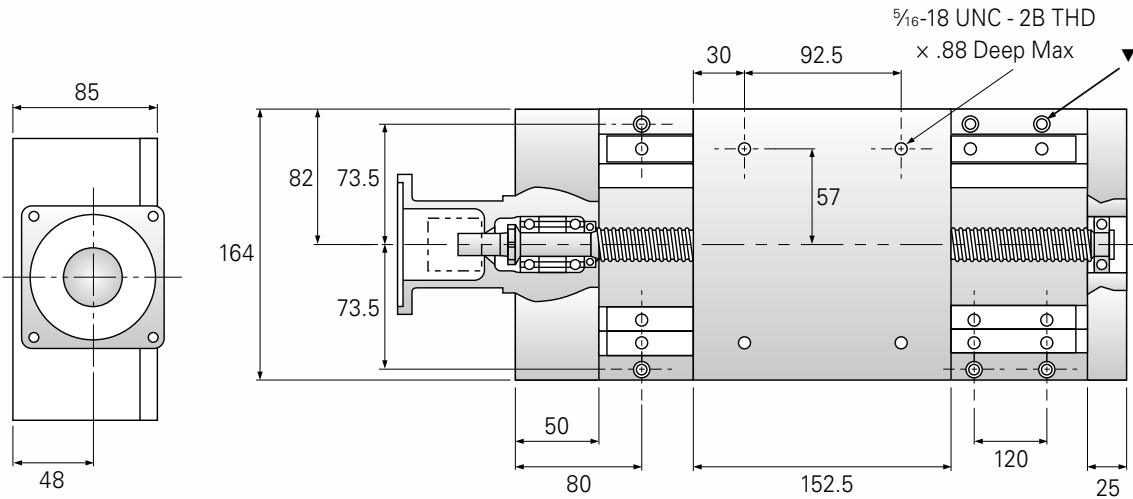

All Nook Precision Slides can be supplied with Stepper Motors, Servo Motor Drives and controllers. Contact factory engineers.

▼ Drilled and Counterbored for M6 or 1/4-20 Socket Head Cap Screws.

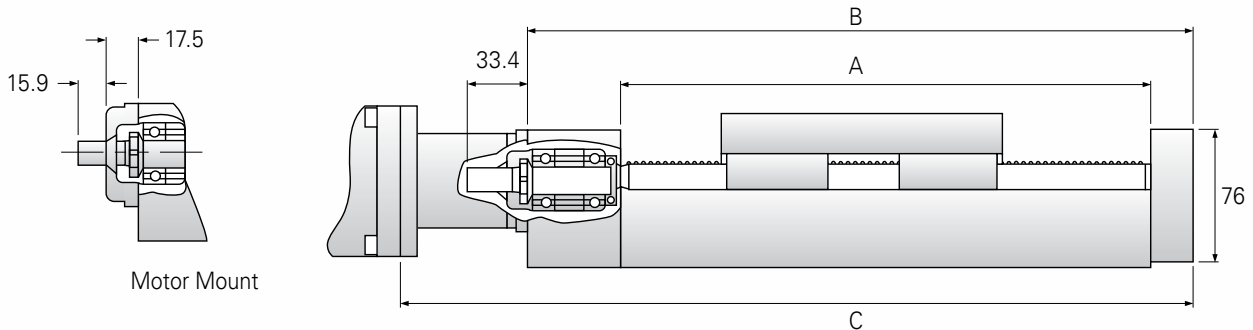

ROUND RAILS / LINEAR BEARINGS



Nook hardened and ground shafting is used extensively in the exercise equipment industry.

LINEAR GUIDANCE

ROUND RAILS / LINEAR BEARINGS



LINEAR BEARING TYPES AND LINEAR SHAFTING 190-191

SELF - ALIGNING BEARINGS AND LLB BEARINGS

Self - Aligning Bearings	192
Pillow Blocks	193-195
LLB Bearings	196-197

LINEAR BEARING SEAL SPECIFICATIONS 198

LINEAR BEARING LUBRICATION 198

PRECISION HG SHAFTING 199

PRECISION END MACHINING 200-201

PRECISION HARDENED GROUND LINEAR SHAFTING 202

SHAFT SUPPORT BLOCKS 203

SHAFT SUPPORT RAIL ASSEMBLIES 203

SHAFT SUPPORT RAILS 204-205

METRIC LINEAR BEARINGS 206

PRECISION HARDENED GROUND METRIC LINEAR SHAFTING 207

LINEAR BEARING TYPES & LINEAR SHAFTING

LINEAR BEARING TYPES

Excel™ Linear Bearings

Designed to fit into precision bores, these bearings are self aligning and offer long life. Precision hardened and ground bearing plates with conforming ball tracks are contained in a molded thermoplastic housing.

LBB

These bearings are used in lower load applications where self alignment is not required. The precision fit between the bearing and shaft is built into the bearing as a result of the solid steel shell. These bearings utilize a molded plastic ball retainer assembled inside a hardened and ground shell.

Open Series Bearings

For applications requiring fully supported shafts, “open” bearings are available in both LBB and Excel™ types. In an open bearing, one ball circuit is removed to allow the mounted bearing to translate along a supported shaft.

Seals

LBB and Excel™ bearings are available in sealed and unsealed versions. ILBB bearings are unsealed.

Materials

Nook linear bearings use a combination of high performance thermoplastic, chrome-steel bearing balls, and either a one piece hardened steel shell or precision ground hardened steel bearing plates. (See FIG. 1)

FIG. 1

	BALLS	BEARING PLATE	BALL RETAINER	END RINGS	INTERNAL SEALS
Excel™ Self - Alining	Hardened Chrome Steel	Hardened Steel	N/A	N/A	Nitrile
LBB SERIES	Hardened Chrome Steel	N/A	Acetal Resin	Steel Black Oxide	Nitrile

FIG. 2

IMPACTS & VIBRATIONS	SPEED	ACCELERATION (G)	LOAD FACTOR (f)
Without external impacts or vibrations	Velocity 50 ft/min	Acceleration < 0.5G	1 ~ 1.5
Without significant impacts or vibrations	Velocity > 50 ft/min and 190 ft/min	Acceleration > 0.5G and 1.0G	1.5 ~ 2.0
Without external impacts or vibrations	Velocity > 190 ft/min	Acceleration > 1.0G and 2.0G	2.0 ~ 3.5

Excel™ Maximum Speed

When used in high speed or high impact environments, Excel™ bearing capacities should be de-rated as shown in the chart. Divide the rated load by the load factor to determine the appropriate bearing size. (See FIG. 2)

LINEAR SHAFTING

Material

Nook HG Shafting, made from high quality alloy steel, is manufactured and stocked for immediate shipment in our Cleveland, Ohio facility, in diameters from 5 to 80mm and ¼ to 4 inches. Stainless Steel shafting is available from ¼ thru 2 inch diameter. Standard diameters can be cut to your specified length and shipped within 24 hours of receipt of your order. Contact Nook Industries, Inc. for availability of special diameters.

Case Hardness

Nook HG alloy shafting is induction hardened to Rc 60-63. Stainless steel shafting is hardened to Rc 50-55. Instrument Series Shafting is hardened to Rc 55-60. The case depth on all Nook HG Shafting is precisely controlled for optimal performance. The extremely hard surface minimizes wear and is resistant to nicks and scratches.

EXCEL™ SELF ALIGNING BEARINGS OPEN & CLOSED

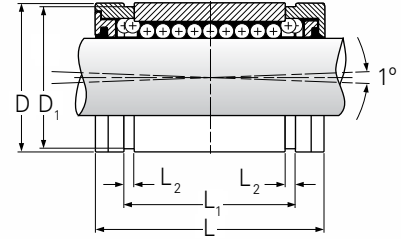

- Designed for use on end supported Nook HG "L" shafting
- Bearings are available with or without shaft seals.

INCH - CLOSED BEARINGS

NOMINAL SHAFT DIA.	EXCEL™ WITHOUT SEAL	EXCEL™ WITH SEAL	NO. OF BALL CIRCUITS	HOUSING BORE DIA. D	DIMENSIONS				LOAD RATING (lb)			
									Dynamic		Static	
					D ₁	L	L ₁	L ₂	Norm.	Max.	Norm.	Max.
¼"	XLEC04	XLEC04UU	4	0.5005/0.5000	0.4687	0.750/0.735	0.511/0.501	0.039	39	45	27	38
⅜"	XLEC06	XLEC06UU	4	0.6255/0.6250	0.5880	0.875/0.860	0.699/0.689	0.039	59	68	43	61
½"	XLEC08	XLEC08UU	4	0.8755/0.8750	0.8209	1.250/1.230	1.032/1.012	0.050	152	175	112	158
⅝"	XLEC10	XLEC10UU	5	1.1255/1.1250	1.0700	1.500/1.480	1.105/1.095	0.056	273	325	187	273
¾"	XLEC12	XLEC12UU	6	1.2505/1.2500	1.1760	1.625/1.605	1.270/1.250	0.056	383	406	274	351
1"	XLEC16	XLEC16UU	6	1.5630/1.5625	1.4900	2.250/2.230	1.884/1.864	0.070	684	725	492	630
1¼"	XLEC20	XLEC20UU	6	2.0008/2.0000	1.8890	2.625/2.600	2.004/1.984	0.068	1,017	1,078	712	911
1½"	XLEC24	XLEC24UU	6	2.3760/2.3750	2.2389	3.000/2.970	2.410/2.390	0.086	1,298	1,376	852	1,091
2"	XLEC32	XLEC32UU	6	3.0010/3.0000	2.8379	4.000/3.960	3.193/3.163	0.105	2,104	2,230	1,458	1,866

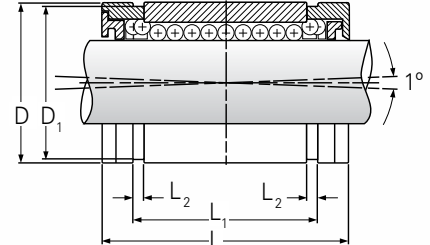
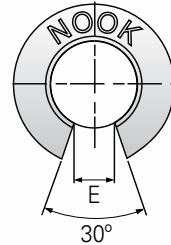

- Designed for use on fully supported Nook HG "L" shafting
- Longitudinal section equal to one ball circuit removed for support rail clearance
- Standard bearing includes shaft seals

INCH - OPEN BEARINGS

NOMINAL SHAFT DIA.	EXCEL™ WITH SEAL	NO. OF BALL CIRCUITS	HOUSING BORE DIA. D	DIMENSIONS					LOAD RATING (lb)			
									Dynamic		Static	
				D ₁	L	L ₁	L ₂	E	Norm.	Max.	Norm.	Max.
½"	XLEN08UU	3	0.8755/0.8750	0.8209	1.250/1.230	1.032/1.012	0.050	0.32	152	152	112	112
⅝"	XLEN10UU	4	1.1255/1.1250	1.0700	1.500/1.480	1.105/1.095	0.056	0.38	315	318	229	236
¾"	XLEN12UU	5	1.2505/1.2500	1.1760	1.625/1.605	1.270/1.250	0.056	0.43	386	398	279	312
1"	XLEN16UU	5	1.5630/1.5625	1.4900	2.250/2.230	1.884/1.864	0.070	0.56	690	711	501	561
1¼"	XLEN20UU	5	2.0008/2.0000	1.8890	2.625/2.600	2.004/1.984	0.086	0.63	1,025	1,056	726	813
1½"	XLEN24UU	5	2.3760/2.3750	2.2389	3.000/2.970	2.410/2.390	0.086	0.75	1,307	1,346	867	971
2"	XLEN32UU	5	3.0010/3.0000	2.8379	4.000/3.960	3.193/3.163	0.105	1.00	2,121	2,185	1,485	1,663

EXCEL™ PILLOW BLOCKS
OPEN & CLOSED

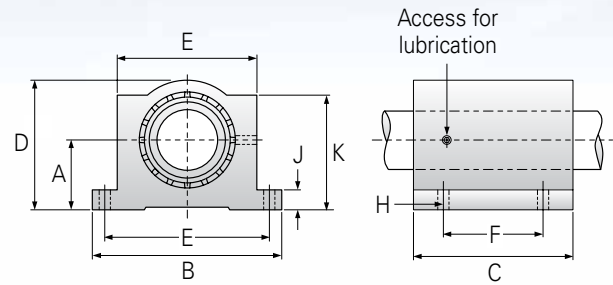

- Sealed at both ends, contains a closed unsealed Excel™ Bearing
- Designed for use on end supported Nook HG “L” shafting

INCH - CLOSED SINGLE PILLOW BLOCKS

NOMINAL SHAFT DIA.	EXCEL™ WITHOUT SEAL	DIMENSIONS											WEIGHT (lb)	LOAD RATING (lb)			
		A	B	C	D	E	F	G	H	J	K	Dynamic		Static			
		±0.001				±0.005	±0.005		Bolt	Hole				Norm.	Max.	Norm.	Max.
3/8"	XEP-06	0.500	1 3/4"	1 5/16"	1 5/16"	1.437	0.875	0.875	#6	0.17	3/16"	7/8"	0.12	59	68	43	61
1/2"	XEP-08	0.687	2"	1 11/16"	1 1/4"	1.688	1.000	1.000	#6	0.17	1/4"	1 1/8"	0.20	152	175	112	158
5/8"	XEP-10	0.875	2 1/2"	1 15/16"	1 3/8"	2.125	1.125	1.125	#8	0.19	9/32"	1 7/16"	0.50	273	325	187	273
3/4"	XEP-12	0.937	2 3/4"	2 1/16"	1 3/4"	2.375	1.250	1.250	#8	0.19	5/16"	1 1/16"	0.60	383	406	274	351
1"	XEP-16	1.187	3 1/4"	2 13/16"	2 3/16"	2.875	1.750	1.750	#10	0.22	3/8"	1 15/16"	1.20	684	725	492	630
1 1/4"	XEP-20	1.500	4"	3 5/8"	2 13/16"	3.500	2.000	2.000	#10	0.22	7/16"	2 1/2"	2.50	1,017	1,078	712	911
1 1/2"	XEP-24	1.750	4 3/4"	4"	3 3/4"	4.125	2.500	2.500	1/4"	0.28	1/2"	2 7/8"	3.80	1,298	1,376	852	1,091
2"	XEP-32	2.125	6"	5"	4 1/16"	5.250	3.250	3.250	3/8"	0.41	5/8"	3 5/8"	7.00	2,104	2,230	1,453	1,866

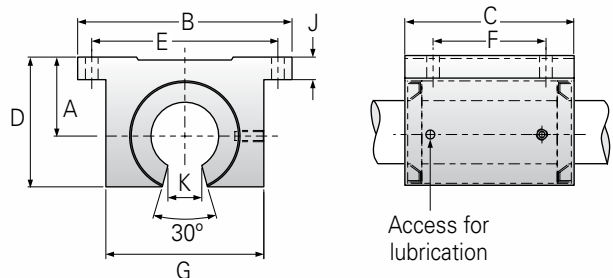

- Sealed at both ends, contains an open, sealed Excel™ Bearing
- Designed for use with fully supported Nook HG “L” shafting
- Longitudinal section equal to one ball circuit removed for support rail clearance

INCH - OPEN SINGLE PILLOW BLOCKS

NOMINAL SHAFT DIA.	EXCEL™ WITHOUT SEAL	DIMENSIONS											WEIGHT (lb)	LOAD RATING (lb)			
		A	B	C	D	E	F	G	H	J	K	Dynamic		Static			
		±0.001				±0.005	±0.005		Bolt	Hole				Norm.	Max.	Norm.	Max.
1/2"	XEP-08-OPN	0.687	2"	1 1/2"	1 1/8"	1.688	1.000	1 3/8"	#6	0.17	1/4"	5/16"	0.20	152	152	112	112
5/8"	XEP-10-OPN	0.875	2 1/2"	1 3/4"	1 7/16"	2.125	1.125	1 3/4"	#8	0.19	9/32"	3/8"	0.40	315	318	229	236
3/4"	XEP-12-OPN	0.937	2 3/4"	1 7/8"	1 9/16"	2.375	1.250	1 7/8"	#8	0.19	5/16"	7/16"	0.50	386	398	279	312
1"	XEP-16-OPN	1.187	3 1/4"	2 5/8"	1 15/16"	2.875	1.750	2 3/8"	#10	0.22	3/8"	9/16"	1.00	690	711	501	561
1 1/4"	XEP-20-OPN	1.500	4"	3 3/8"	2 1/2"	3.500	2.000	3"	#10	0.22	7/16"	5/8"	2.10	1,025	1,056	726	813
1 1/2"	XEP-24-OPN	1.750	4 3/4"	3 3/4"	2 7/8"	4.125	2.500	3 1/2"	1/4"	0.28	1/2"	3/4"	3.20	1,307	1,346	867	971
2"	XEP-32-OPN	2.125	6"	4 3/4"	3 5/8"	5.250	3.250	4 1/2"	3/8"	0.41	5/8"	1"	6.00	2,121	2,185	1,485	1,663

EXCEL™ PILLOW BLOCKS OPEN & CLOSED

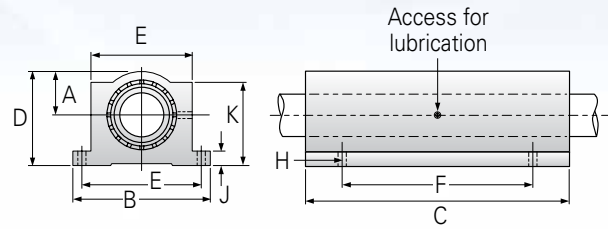

* Lubrication holes for blocks up to 1/2" have flush lube fitting; 5/8" and above are 1/4 - 28 tapped hole with set screw

- Sealed at both ends, contains two closed unsealed Excel™ Bearings
- Designed for use on end supported Nook HG "L" shafting

INCH - CLOSED TWIN PILLOW BLOCKS

NOMINAL SHAFT DIA.	EXCEL™ WITHOUT SEAL	DIMENSIONS											WEIGHT (lb)	LOAD RATING (lb)			
		A	B	C	D	E	F	G	H	J	K	Dynamic		Static			
		±0.001				±0.005	±0.005		Bolt Hole					Norm.	Max.	Norm.	Max.
3/8"	TEP-06	0.500	1 3/4"	2 3/4"	1 5/16"	1.437	2.250	1 1/8"	#6	0.17	3/16"	7/8"	0.25	118	136	86	122
1/2"	TEP-08	0.687	2"	3 1/2"	1 1/4"	1.688	2.500	1 3/8"	#6	0.17	1/4"	1 1/8"	0.40	304	350	224	316
5/8"	TEP-10	0.875	2 1/2"	4"	1 5/8"	2.125	3.000	1 3/4"	#8	0.19	9/32"	1 1/16"	1.00	546	650	374	546
3/4"	TEP-12	0.937	2 3/4"	4 1/2"	1 3/4"	2.375	3.500	1 7/8"	#8	0.19	5/16"	1 1/16"	1.20	766	812	548	702
1"	TEP-16	1.187	3 1/4"	6"	2 3/16"	2.875	4.500	2 3/8"	#10	0.22	3/8"	1 15/16"	2.40	1,368	1,450	984	1,260
1 1/4"	TEP-20	1.500	4"	7 1/2"	2 13/16"	3.500	5.500	3"	#10	0.22	7/16"	2 1/2"	5.00	2,034	2,156	1,424	1,822
1 1/2"	TEP-24	1.750	4 3/4"	9"	3 1/4"	4.125	6.500	3 1/2"	1/4"	0.28	1/2"	2 7/8"	7.80	2,596	2,752	1,704	2,182
2"	TEP-32	2.125	6"	10"	4 1/16"	5.250	8.250	4 1/2"	3/8"	0.41	5/8"	3 5/8"	14.50	4,208	4,460	2,916	3,732

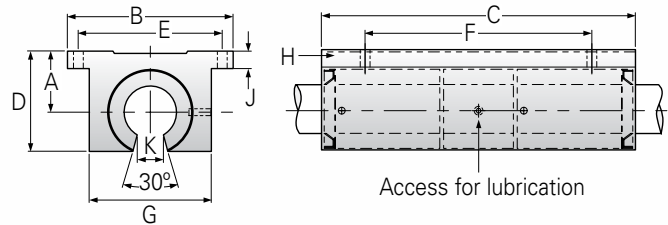

* Lubrication holes for blocks up to 1/2" have flush lube fitting; 5/8" and above are 1/4 - 28 tapped hole with set screw

Sealed at both ends, contains two open, sealed Excel™ Bearings

- Designed for use with fully supported Nook HG "L" shafting
- Longitudinal section equal to one ball circuit removed for support rail clearance

INCH - OPEN TWIN PILLOW BLOCKS

NOMINAL SHAFT DIA.	EXCEL™ WITHOUT SEAL	DIMENSIONS											WEIGHT (lb)	LOAD RATING (lb)			
		A	B	C	D	E	F	G	H	J	K	Dynamic		Static			
		±0.001				±0.005	±0.005		Bolt Hole					Norm.	Max.	Norm.	Max.
1/2"	TEP-08-OPN	0.687	2"	3 1/2"	1.13	1.688	2.500	1 3/8"	#6	0.17	1/4"	5/16"	0.40	304	304	224	224
5/8"	TEP-10-OPN	0.875	2 1/2"	4"	1.44	2.125	3.000	1 3/4"	#8	0.19	9/32"	3/8"	0.80	630	636	458	472
3/4"	TEP-12-OPN	0.937	2 3/4"	4 1/2"	1.56	2.375	3.500	1 7/8"	#8	0.19	5/16"	7/16"	1.00	772	796	558	624
1"	TEP-16-OPN	1.187	3 1/4"	6"	1.94	2.875	4.500	2 3/8"	#10	0.22	3/8"	9/16"	2.00	1,380	1,422	1,002	1,122
1 1/4"	TEP-20-OPN	1.500	4"	7 1/2"	2.50	3.500	5.500	3"	#10	0.22	7/16"	5/8"	4.20	2,050	2,112	1,452	1,626
1 1/2"	TEP-24-OPN	1.750	4 3/4"	9"	2.88	4.125	6.500	3 1/2"	1/4"	0.28	1/2"	3/4"	6.70	2,614	2,692	1,734	1,942
2"	TEP-32-OPN	2.125	6"	10"	3.63	5.250	8.250	4 1/2"	3/8"	0.41	5/8"	1"	12.50	4,242	4,370	2,970	3,326

EXCEL™ PILLOW BLOCKS
FLANGE-MOUNT SINGLE & TWIN

Excel™ Linear Bearings provide high efficiency and smooth operation in a variety of linear guidance applications. Excel™ Flange-Mount Pillow Blocks offer an installation alternative to standard foot-mount pillow blocks when the mounting surface is perpendicular to the guide shafts. Nook Industries flanged mount pillow blocks are available in both single and twin bearing styles

and include ½ , ¾ or 1 inch Excel™ Linear Bearings. The blocks have integral lip seals, an aluminum housing and a lubrication port. Typical applications include: platform guidance, end stop support, conveyor width adjust mechanisms, edge guides and machine operator guards.

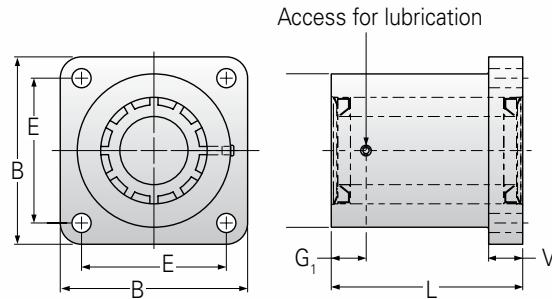

- Sealed at both ends, contains unsealed Excel™ Bearing (two bearings in twin)
- Designed for use on end supported Nook HG “L” shafting

INCH - CLOSED BEARINGS

	NOMINAL SHAFT DIA.	EXCEL™ PART NO.	DIMENSIONS							LOAD RATING (lb)			
			B	E ±0.005	L	D	V	G ₁	S Hole Dia.	Dynamic		Static	
										Norm.	Max.	Norm.	Max.
Single	½"	XEP-08-FLM	1.63	1.250	1.69	1.25	0.25	0.35	0.19	152	175	112	158
	¾"	XEP-12-FLM	2.38	1.750	2.06	1.75	0.38	0.37	0.22	383	406	274	351
	1"	XEP-16-FLM	2.75	2.125	2.81	2.25	0.50	0.51	0.28	684	725	492	630
Twin	½"	TEP-08-FLM	1.63	1.250	3.20	1.25	0.90	1.60	0.19	304	350	224	316
	¾"	TEP-12-FLM	2.38	1.750	3.95	1.75	0.90	1.60	0.22	766	812	548	702
	1"	TEP-16-FLM	2.75	2.125	5.33	2.25	0.90	2.70	0.28	1,368	1,450	984	1,260

LINEAR BEARINGS LBB SERIES

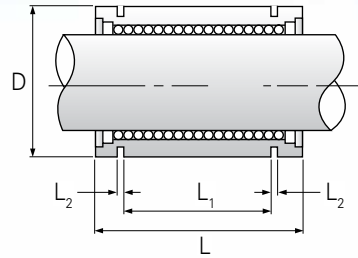

- Designed for use on end supported Nook HG "L" shafting
- Solid steel shell, no seals

INCH - LBB PRECISION CLOSED BEARINGS

NOMINAL SHAFT DIA.	LBB BEARING PART NUMBER	DIMENSIONS				WEIGHT (lb)	DYNAMIC LEAD (lb)	STATIC LEAD (lb)
		D	L	L ₁	L ₂			
¼"	LBB-250	0.5000/0.4996	.750	.437	.040	.02	25	27
⅜"	LBB-375	0.6250/0.6246	.875	.562	.040	.04	38	36
½"	LBB-500	0.8750/0.8746	1.250	.875	.047	.11	88	79
⅝"	LBB-625	1.1250/1.1246	1.500	1.00	.058	.22	160	139
¾"	LBB-750	1.2500/1.2496	1.625	1.062	.058	.26	204	191
1"	LBB-1000	1.5625/1.5621	2.250	1.625	.070	.50	371	353
1¼"	LBB-1250	2.0000/1.9995	2.625	1.875	.070	.91	724	712
1½"	LBB-1500	2.3750/2.3745	3.000	2.250	.088	1.44	948	831
2"	LBB-2000	3.0000/2.9994	4.000	3.000	.105	2.78	1,391	1,434



LINEAR BEARINGS LBB OPEN SERIES

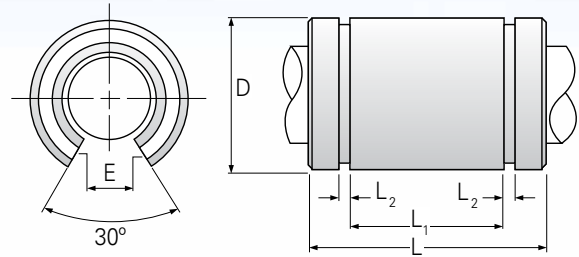

- Designed for use on fully supported Nook HG "L" shafting
- Longitudinal section equal to one ball circuit removed for support rail clearance
- Solid steel shell, with no seals

INCH - LBB PRECISION OPEN BEARINGS

NOMINAL SHAFT DIA.	LBB BEARING PART NUMBER	DIMENSIONS							WEIGHT (lb)	DYNAMIC LEAD (lb)	STATIC LEAD (lb)
		D	L	L ₁	L ₂	E	F				
1/2"	OPN-500	0.8750/0.8746	1.250	.875	.047	9/32	60°	.11	88	79	
5/8"	OPN-625	1.1250/1.1246	1.500	1.000	.058	3/8	60°	.22	160	139	
3/4"	OPN-750	1.2500/1.2496	1.625	1.062	.058	13/32	60°	.26	204	236	
1"	OPN-1000	1.5625/1.5621	2.250	1.625	.070	9/16	60°	.50	445	438	
1 1/4"	OPN-1250	2.0000/1.9995	2.625	1.875	.070	5/8	50°	.91	724	726	
1 1/2"	OPN-1500	2.3750/2.3745	3.000	2.250	.088	3/4	50°	1.44	948	845	
2"	OPN-2000	3.0000/2.9994	4.000	3.000	.105	1	50°	2.78	1,391	1,461	

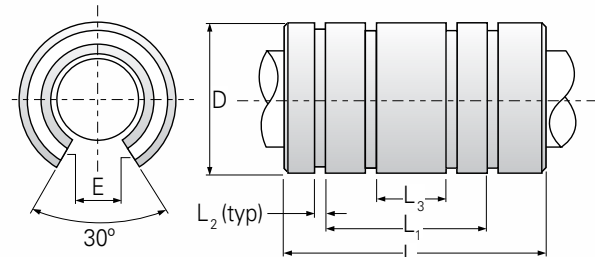

- Designed for use on fully supported Nook HG "L" shafting
- Longitudinal section equal to one ball circuit removed for support rail clearance
- Solid steel shell, with lip seals

INCH - LBB PRECISION OPEN SEALED BEARINGS

NOMINAL SHAFT DIA.	LBB BEARING PART NUMBER	DIMENSIONS							WEIGHT (lb)	DYNAMIC LEAD (lb)	STATIC LEAD (lb)
		D	L	L ₁	L ₂	L ₃	E	F			
1/2"	OPN-500PP	0.8750/0.8746	1.438	.875	.047	.531	9/32	60°	.12	88	79
5/8"	OPN-625PP	1.1250/1.1246	1.688	1.000	.058	—	3/8	60°	.24	160	139
3/4"	OPN-750PP	1.2500/1.2496	1.875	1.062	.058	.687	13/32	60°	.29	204	236
1"	OPN-1000PP	1.5625/1.5621	2.500	1.625	.070	.844	9/16	60°	.52	445	438
1 1/4"	OPN-1250PP	2.0000/1.9995	3.125	1.875	.070	1.031	5/8	50°	1.12	724	726
1 1/2"	OPN-1500PP	2.3750/2.3745	3.438	2.250	.088	1.219	3/4	50°	1.62	948	845
2"	OPN-2000PP	3.0000/2.9994	4.750	3.000	.105	1.531	1	50°	3.08	1,391	1,461

LINEAR BEARINGS

SEAL SPECIFICATIONS

Nook Linear Bearing Seals are designed for use in custom housings where additional sealing is desired. They are made of a synthetic rubber compound to allow smooth linear motion with maximum sealing efficiency.

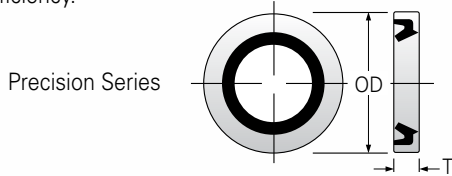

	POWERTRAX LINEAR BEARING	SHAFT DIA. (in)	PART NUMBER	DIMENSIONS	
				T	O.D.
Precision Seals	LBB-250	¼"	LS-250	0.125	0.504
	LBB-375	⅜"	LS-375	0.125	0.629
	LBB-500	½"	LS-500	0.125	0.879
	LBB-625	⅝"	LS-625	0.125	1.129
	LBB-750	¾"	LS-750	0.125	1.254
	LBB-1000	1"	LS-1000	0.187	1.567
	LBB-1250	1¼"	LS-1250	0.375	2.004
	LBB-1500	1½"	LS-1500	0.375	2.379
	LBB-2000	2"	LS-2000	0.375	3.004
Stainless Steel Seals	LBB-250SS	¼"	LS-250SS	0.125	0.504
	LBB-375SS	⅜"	LS-375SS	0.125	0.629
	LBB-500SS	½"	LS-500SS	0.125	0.879
	LBB-625SS	⅝"	LS-625SS	0.125	1.129
	LBB-750SS	¾"	LS-750SS	0.125	1.254
	LBB-1000SS	1"	LS-1000SS	0.187	1.567

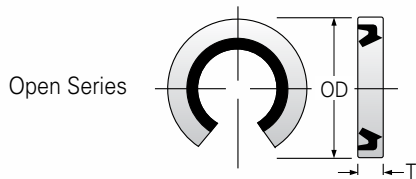

	POWERTRAX LINEAR BEARING	SHAFT DIA. (in)	PART NUMBER	DIMENSIONS	
				T	O.D.
Precision Seals	OPN-500	½"	LSO-500	0.125	0.629
	OPN-652	⅝"	LSO-625	0.125	0.879
	OPN-750	¾"	LSO-750	0.125	1.254
	OPN-1000	1"	LSO-1000	0.187	1.567
	OPN-1250	1¼"	LSO-1250	0.375	2.004
	OPN-1500	1½"	LSO-1500	0.375	2.379
Stainless Steel Seals	OPN-375SS	⅜"	LSO-375SS	0.125	0.629
	OPN-500SS	½"	LSO-500SS	0.125	0.879
	OPN-625SS	⅝"	LSO-625SS	0.125	1.129
	OPN-750SS	¾"	LSO-750SS	0.125	1.254
	OPN-1000SS	1"	LSO-1000SS	0.187	1.567

LUBRICATION

Prolong Bearing Assembly Reliability and Life

Lubrication is the key to continued performance and reliability of bearing assemblies. LBL-1 is a multi-purpose pure synthetic lubricant. The stable and predictable chemical properties of LBL-1 help it last longer and outperform conventional petroleum based greases and oils. Lubricant additives fill microscopic surface irregularities to form a smooth, lubricated surface.

LBL-1 Lubricant Features And Benefits

- Synthetic, non-toxic, odorless
- Low coefficient of friction
- Free flowing down to -40°
- USDA H-1 rating
- Water and saltwater Resistant
- Won't drip, run or evaporate
- Inhibits rust and corrosion
- Long lasting
- Reduces friction and wear



LBL-1 SPECIFICATIONS

Iso Grade	220	
Penetration (Worked)	285	
Dropping Point	N/A	
Gelling Agent	Synthetic	
Timken Ok Load	40 lb	
Oil Viscosity	cst @ 400C	118-122
	cst @ 1000C	14-17
Temperature Range	-45° F TO 450° F	

LBL-1 4 OZ. LIQUID BEARING BOTTLE

LBL-1 SPECIFICATIONS

Part Name	LBL-1
Net Contents Per Unit	4 oz.
Part # NLU-1006	1 BOTTLE weight of 4 oz.
Part # NLU-2006	1 CASE with 12 Bottles total weight of 3 lb

PRECISION HG SHAFTING

HG HARDENED AND GROUND SHAFTING

Nook HG Shafting, made from high quality alloy steel, is manufactured and stocked for immediate shipment in our Cleveland, Ohio facility, in diameters from 5 to 80mm and ¼ to 4 inches. Stainless Steel shafting is available from ¼ thru 2 inch diameter.

Standard diameters can be cut to your specified length and shipped within 24 hours of receipt of your order. Contact Nook Industries, Inc. for availability of special diameters.

CASE HARDNESS

Nook HG alloy shafting is induction hardened Rc 60-63. Stainless steel shafting is hardened to Rc 50-55. Instrument series shafting is hardened to Rc 55-60. The case depth on all Nook HG Shafting is precisely controlled for optimal performance. The extremely hard surface minimizes wear and is resistant to nicks and scratches.



PRECISION END MACHINING

Nook HG hardened and ground shafting is manufactured for use with precision linear bearings and other applications requiring an accurate, round, hardened shaft or guide rod. All linear shafting

can be machined by Nook Industries to any of the configurations detailed below. Templates for machining are available on our website: www.nookindustries.com

RADIAL HOLES DRILLED AND TAPPED

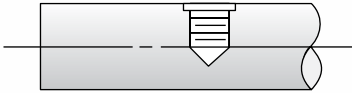

Radial drilled and tapped holes are available with either UNC or UNF Class 2B thread. The hole alignment and location tolerance is $\pm .010$ "

COAXIAL HOLES

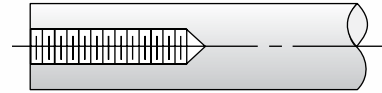

Coaxial holes are machined with concentricity of $.005$ " centered in the shaft end for shafting $\frac{1}{2}$ inch diameter and larger. UNC or UNF Class 2B internal threads are available. Based on tapped hole size, some ends may require annealing and will remain soft on the outside diameter.

RETAINING RING GROOVES



Retaining ring or other grooves area available for all diameter shafting. Annealing may be required in the machined area.

OPTIONAL MACHINED CHAMFER

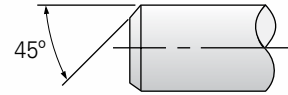

Cut shafts are supplied with Nook non-precision standard end chamfers. Specific chamfer dimensions may be specified.



Nook Linear Shafting and Bearings used to guide a loader for medical waste processing.

LINEAR GUIDANCE

ROUND RAILS / LINEAR BEARINGS



Nook Linear Shafting and Bearings used as guidance in a medical application.

THREADED DIAMETERS

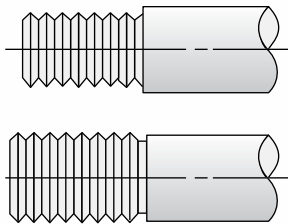

Either the major diameter or reduced diameter may be threaded to UNC or UNF Class 2A. Threaded areas will not have full depth of hardness.

REDUCED DIAMETER

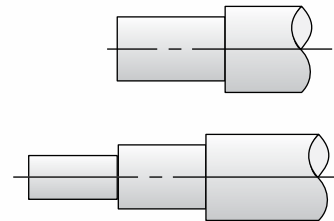

Single or multiple-step machined diameters are available. Concentricity held to within .002". The reduced diameters will not have full hardness.

FLATS – SINGLE OR MULTIPLE

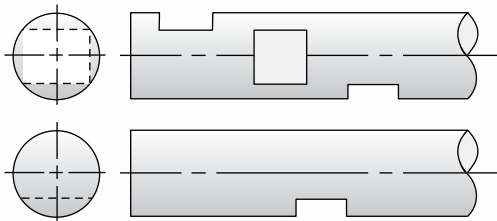

Flats have a location tolerance of $\pm 1/64"$. Multiple flats available on single plane or different planes with location tolerance $\pm 1/64"$. Contact Nook Industries for flat length limits.

KEYWAYS

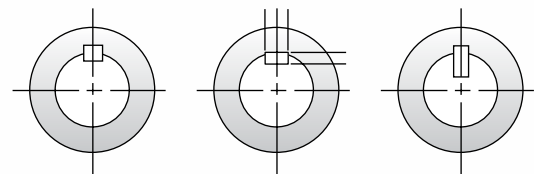

Keyways are available for square, rectangular or ANSI Standard Woodruff keys. Keyway will not have full hardness.

PRECISION HARDENED GROUND LINEAR SHAFTING



NON PRE-DRILLED SHAFTING

PART NUMBER	NOMINAL DIAMETER (in)	TOLERANCES CLASS "L" DIAMETER (in)	MAXIMUM LENGTH (ft.)	MINIMUM DEPTH OF HARDNESS (in)	WEIGHT PER INCH OF LENGTH (lb)
L-1/4*	1/4	.2495/.2490	10 (12)*	.030	.014
L-3/8*	3/8	.3745/.3740	10 (12)*	.030	.03
L-1/2*	1/2	.4995/.4990	18 (12)*	.050	.06
L-5/8*	5/8	.6245/.6240	18 (12)*	.050	.09
L-3/4*	3/4	.7495/.7490	18 (12)*	.060	.13
L-1*	1	.9995/.9990	18 (12)*	.080	.22
L-1-1/4*	1 1/4	1.2495/1.2490	18 (12)*	.080	.35
L-1-1/2*	1 1/2	1.4994/1.4989	18 (12)*	.080	.50
L-2*	2	1.9994/1.9987	18 (12)*	.100	.89
L-2-1/2	2 1/2	2.4993/2.4985	18	.100	1.39
L-3	3	2.9992/2.9983	18	.100	2.00
L-4	4	3.9988/3.9976	18	.100	3.56

* Available in stainless steel. For longer lengths contact Nook Industries.

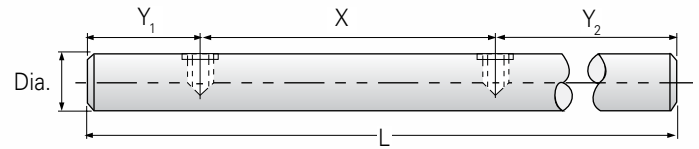

PRE-DRILLED SHAFTING

PART NUMBER	NOMINAL DIAMETER (in)	TOLERANCES CLASS "L" DIAMETER (in)	HOLE SPACING (in) X	THREAD SIZE	WEIGHT PER INCH OF LENGTH (lb)	MAXIMUM LENGTH (ft.)
PDL 1/2*	1/2	.4995/.4990	4	6-32	.06	12
PDL 5/8*	5/8	.6245/.6240	4	8-32	.09	12
PDL 3/4*	3/4	.7495/.7490	6	10-32	.13	12
PDL 1*	1	.9995/.9990	6	1/4-20	.22	12
PDL 1-1/4	1 1/4	1.2495/1.2490	6	5/16-18	.35	12
PDL 1-1/2	1 1/2	1.4994/1.4989	8	3/8-16	.50	12
PDL 2	2	1.9994/1.9987	8	1/2-13	.89	12

Holes are drilled and tapped to center of shaft. For different hole spacing contact Nook Industries.

$Y_1 = Y_2$ Custom Y dimensions now available.

SHAFT SUPPORT BLOCKS



Material—
 Aluminum Alloy

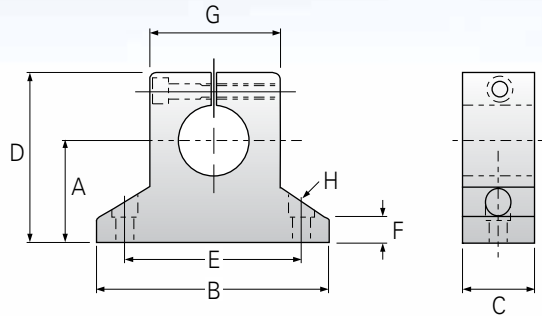

SHAFT SUPPORT BLOCKS

PART NO.	NOM. SHAFT DIA. (in)	A ±.002	B	C	DIMENSIONS						Bolt	Hole	WEIGHT EACH
					D	E	F	G					
NSB-4	¼	.687	1½"	½"	1⅛"	1⅛"	¼"	.63	#6	5/32"	.04		
NSB-6	⅜	.750	1⅝"	9/16"	1⅜"	1¼"	¼"	.75	#6	5/32"	.06		
NSB-8	½	1.000	2"	5/8"	1⅝"	1½"	¼"	.88	#8	3/16"	.09		
NSB-10	5/8	1.000	2½"	11/16"	1¾"	1⅝"	5/16"	1.13	#10	7/32"	.14		
NSB-12	¾	1.250	2¾"	¾"	2⅞"	2"	5/16"	1.25	#10	7/32"	.20		
NSB-16	1	1.500	3¼"	1"	2⅞"	2½"	3/8"	1.50	¼"	9/32"	.37		
NSB-20	1¼	1.750	4"	1⅝"	3"	3"	7/16"	2.00	5/16"	11/32"	.63		
NSB-24	1½	2.000	4¾"	1¼"	3½"	3½"	½"	2.25	5/16"	11/32"	.93		
NSB-32	2	2.500	6"	1½"	4⅝"	4½"	5/8"	3.00	3/8"	13/32"	1.79		

SHAFT SUPPORT RAIL ASSEMBLIES

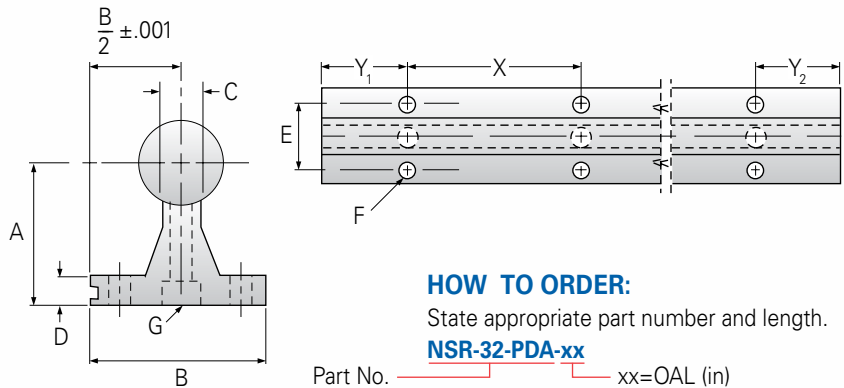
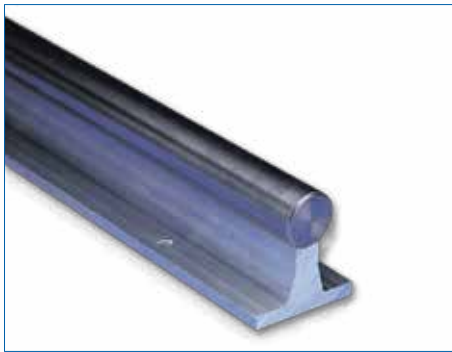

HOW TO ORDER:

State appropriate part number and length.

NSR-32-PDA-xx

Part No. _____ xx=OAL (in)

PRE-DRILLED SHAFT SUPPORT ASSEMBLIES

PART NO.	NOM. SHAFT DIA. (in)	A ±.002	B	C	D	E	DIMENSIONS				X	WEIGHT PER FT. (lb)
							Bolt	Hole	Screw	Hole		
NSR-8-PDA	½	1.125	1½"	¼"	3/16"	1"	6	.169	6-32 × 7/8	.169"	4	1.26
NSR-10-PDA	5/8	1.125	1⅝"	5/16"	¼"	1⅝"	8	.193	8-32 × 7/8	.193"	4	1.83
NSR-12-PDA	¾	1.500	1¾"	3/8"	¼"	1¼"	10	.221	10-32 × 7/8	.221"	6	2.50
NSR-16-PDA	1	1.750	2⅞"	½"	¼"	1½"	¼"	.281	¼-20 × 1½	.281"	6	4.06
NSR-20-PDA	1¼	2.125	2½"	9/16"	5/16"	1⅞"	5/16"	.343	5/16-18 × 1¾	.343"	6	6.28
NSR-24-PDA	1½	2.500	3"	11/16"	3/8"	2¼"	3/8"	.406	3/8-16 × 2	.406"	8	8.60
NSR-32-PDA	2	3.250	3¾"	7/8"	½"	2¾"	½"	.531	½-13 × 2½	.531"	8	14.88

Y₁ = Y₂ Custom Y dimensions now available.

SHAFT SUPPORT RAILS

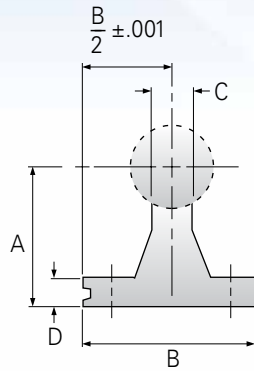

STANDARD LENGTHS: 24", 36", and 48"
 MATERIAL: Aluminum alloy extrusion

HOW TO ORDER:

State appropriate part number and length. Special lengths available, contact the factory.

NSR-10-xx

Part No. _____ xx=OAL (in)

SHAFT SUPPORT RAILS

PART NO.	NOMINAL SHAFT DIA. (in)	DIMENSIONS				WEIGHT PER FT. (lb)
		A ±.002	B	C	D	
NSR-8	1/2	1.125	1 1/2"	1/4"	3/16"	.6
NSR-10	5/8	1.125	1 5/8"	5/16"	1/4"	.8
NSR-12	3/4	1.500	1 3/4"	3/8"	1/4"	1.0
NSR-16	1	1.750	2 1/8"	1/2"	1/4"	1.4
NSR-20	1 1/4	2.125	2 1/2"	9/16"	5/16"	2.1
NSR-24	1 1/2	2.500	3"	1 1/16"	3/8"	2.6
NSR-32	2	3.250	3 3/4"	7/8"	1/2"	4.2

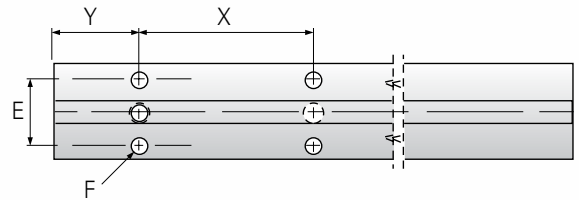
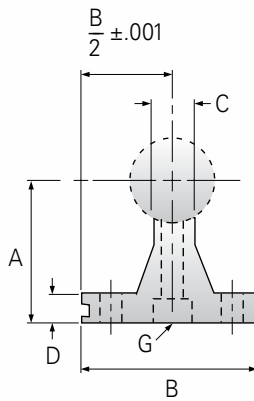

STANDARD LENGTHS: 24", 36", and 48"
 MATERIAL: Aluminum alloy extrusion

HOW TO ORDER:

State appropriate part number and length.

NSR-8-PD-xx

Part No. _____ xx=OAL (in)

PRE-DRILLED SHAFT SUPPORT RAILS

PART NO.	NOM. SHAFT DIA. (in)	DIMENSIONS										WEIGHT PER FT. (lb)	
		A ±.002	B	C	D	E	F		G		Y		X
							Bolt	Hole	Screw	Hole			
NSR-8-PD	1/2	1.125	1 1/2"	1/4"	3/16"	1"	6	.169	6-32 x 7/8	.169"	2	4	.5
NSR-10-PD	5/8	1.125	1 5/8"	5/16"	1/4"	1 1/8"	8	.193	8-32 x 7/8	.193"	2	4	.7
NSR-12-PD	3/4	1.500	1 3/4"	3/8"	1/4"	1 1/4"	10	.221	10-32 x 7/8	.221"	3	6	.9
NSR-16-PD	1	1.750	2 1/8"	1/2"	1/4"	1 1/2"	1 1/4"	.281	1/4-20 x 1 1/2	.281"	3	6	1.2
NSR-20-PD	1 1/4	2.125	2 1/2"	9/16"	5/16"	1 7/8"	5/16"	.343	5/16-18 x 1 3/4	.343"	3	6	2.0
NSR-24-PD	1 1/2	2.500	3"	1 1/16"	3/8"	2 1/4"	3/8"	.406	3/8-16 x 2	.406"	4*	8	2.4
NSR-32-PD	2	3.250	3 3/4"	7/8"	1/2"	2 3/4"	1/2"	.531	1/2-13 x 2 1/2	.531"	4*	8	4.0

*2 on 36" length

SHAFT SUPPORT RAILS LOW PROFILE

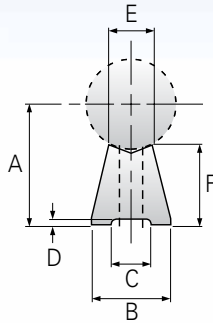

STANDARD LENGTHS: 12", 24", 36", and 48"
 MATERIAL: Aluminum alloy extrusion

HOW TO ORDER:

State appropriate part number and length.

NLR-10-xx

Part No. _____ xx=OAL (in)

LOW-PROFILE: SHAFT SUPPORT RAILS

PART NO.	NOMINAL SHAFT DIA. (in)	DIMENSIONS						WEIGHT PER FT. (lb)
		A ±.002	B	C	D	E (Ref.)	F (Ref.)	
NLR-8	½	.5625	.370	.169	.04	.216	.336	.11
NLR-10	⅝	.6875	.450	.193	.04	.262	.403	.17
NLR-12	¾	.7500	.510	.221	.06	.328	.411	.21
NLR-16	1	1.000	.690	.281	.06	.440	.548	.36
NLR-20	1¼	1.1875	.780	.343	.09	.511	.616	.45
NLR-24	1½	1.3750	.930	.406	.09	.624	.691	.60

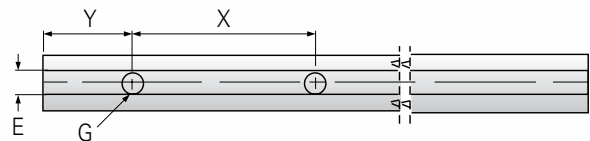
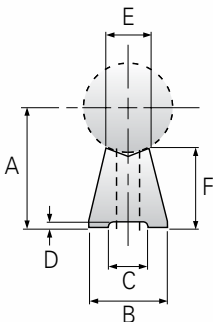

STANDARD LENGTHS: 12", 24", 36", and 48"
 MATERIAL: Aluminum alloy extrusion

HOW TO ORDER:

State appropriate part number and length.

NLR-8-PD-xx

Part No. _____ xx=OAL (in)

LOW PROFILE: PRE-DRILLED SHAFT SUPPORT RAILS

PART NO.	NOMINAL SHAFT DIA. (in)	DIMENSIONS										WEIGHT PER FT. (lb)
		A ±.002	B	C	D	E (Ref.)	F (Ref.)	G Bolt	Hole	Y	X	
NLR-8-PD	½	.5625	.370	.169	.04	.216	.336	6	.169	2	4	.11
NLR-10-PD	⅝	.6875	.450	.193	.04	.262	.403	8	.193	2	4	.17
NLR-12-PD	¾	.7500	.510	.221	.06	.328	.411	10	.221	3	6	.21
NLR-16-PD	1	1.000	.690	.281	.06	.440	.548	¼	.281	3	6	.36
NLR-20-PD	1¼	1.1875	.780	.343	.09	.511	.616	⅙	.343	3	6	.45
NLR-24-PD	1½	1.3750	.930	.406	.09	.624	.691	⅜	.406	4*	8	.60

*2 on 36" length

EXCEL™ LINEAR BEARINGS OPEN & CLOSED

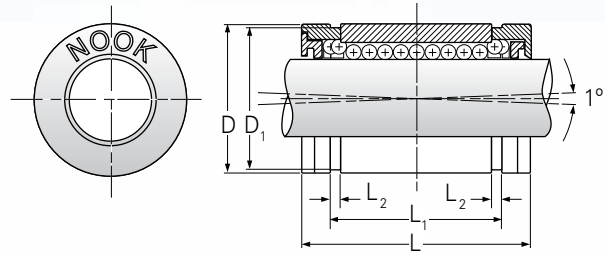

- Designed for use on end supported Nook HG "M" shafting
- Bearings are available with or without shaft seals

METRIC - CLOSED BEARINGS

NOMINAL SHAFT DIA.	EXCEL™ WITHOUT SEAL	EXCEL™ WITH SEAL	NO. OF BALL CIRCUITS	HOUSING BORE DIA. D	DIMENSIONS				LOAD RATING (N)		
					D ₁	L	L ₁	L ₂	Dynamic C		Static C ₀
									Norm.	Max.	
10mm	XLMC10	XLMC10UU	5	19.06/19.03	18	29	21.7	1.35	500	575	390
12mm	XLMC12	XLMC12UU	5	22.08/22.03	21	32	22.7	1.35	650	750	520
16mm	XLMC16	XLMC16UU	5	26.10/26.03	24.9	36	24.7	1.35	800	920	630
20mm	XLMC20	XLMC20UU	5	32.10/32.05	30.3	45	31.3	1.65	1,500	1,560	1,250
25mm	XLMC25	XLMC25UU	5	40.10/40.05	38	58	43.8	1.90	2,500	2,600	2,200
30mm	XLMC30	XLMC30UU	5	47.15/47.05	45.5	68	51.8	1.90	3,200	3,330	2,800
40mm	XLMC40	XLMC40UU	5	62.15/62.05	59	80	60.4	2.20	5,500	5,720	4,900
50mm	XLMC50	XLMC50UU	5	75.20/75.05	72	100	77.4	2.70	8,600	8,940	7,100

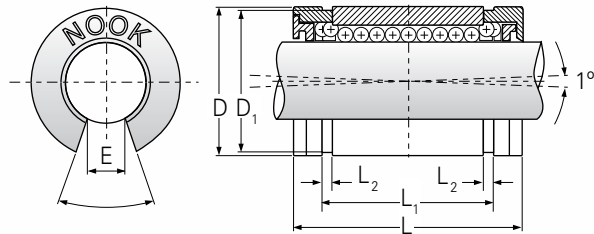

- Designed for use on fully supported shafting
- Longitudinal section equal to one ball circuit removed for support rail clearance
- Standard bearing includes shaft seals

METRIC - OPEN BEARINGS

NOMINAL SHAFT DIA.	EXCEL™ WITH SEAL	NO. OF BALL CIRCUITS	HOUSING BORE DIA. D	DIMENSIONS					LOAD RATING (N)	
				D ₁	L	L ₁	L ₂	E	Dynamic C	Static C ₀
12mm	XLMN12UU	4	22.08/22.03	21	32	22.7	1.35	6.5	750	600
16mm	XLMN16UU	4	26.10/26.03	24.9	36	24.7	1.35	9.0	920	730
20mm	XLMN20UU	5	32.10/32.05	30.3	45	31.3	1.65	9.0	1,560	1,300
25mm	XLMN25UU	5	40.10/40.05	38	58	43.8	1.90	11.5	2,600	1,290
30mm	XLMN30UU	5	47.15/47.05	45.5	68	51.8	1.90	14.0	3,300	2,910
40mm	XLMN40UU	5	62.15/62.05	59	80	60.4	2.20	19.5	5,720	5,100
50mm	XLMN50UU	5	75.20/75.05	72	100	77.4	2.70	22.5	8,940	7,380

**PRECISION HARDENED
GROUND METRIC LINEAR SHAFTING**



PART NUMBER	NOMINAL DIAMETER (mm)	TOLERANCES CLASS "M" DIAMETER (m)	MAXIMUM LENGTH (m)	MINIMUM DEPTH OF HARDNESS (mm)	WEIGHT PER METER OF LENGTH (kg)	WEIGHT PER INCH OF LENGTH (lb)
5mm	5	+0/-8	3.0	1.0	.15	.009
8mm	8	+0/-9	3.0	1.0	.39	.022
10mm	10	+0/-9	5.5	1.0	.62	.034
12mm	12	+0/-11	5.5	1.0	.89	.050
16mm	16	+0/-11	5.5	1.7	1.57	.088
20mm	20	+0/-13	5.5	1.7	2.46	.14
25mm	25	+0/-13	5.5	2.7	3.84	.22
30mm	30	+0/-13	5.5	2.7	5.53	.31
40mm	40	+0/-16	5.5	2.7	9.83	.55
50mm	50	+0/-16	5.5	3.7	15.36	.86
60mm	60	+0/-19	5.5	3.7	22.12	1.24
80mm	80	+0/-19	5.5	3.7	39.33	2.21



REQUEST FOR QUOTE 216.271.7900

Date: _____

Pages (Including this cover): _____

Customer: _____

Address: _____ City: _____

State / Province: _____ Zip: _____ Country: _____

Contact Name: _____

Phone: _____ Fax: _____

Email: _____

Application Details: _____ Quantity: _____

FAX CUSTOMER SERVICE AT: (216) 271-7020 with a copy of your drawing or select a template from the following pages that best matches your application requirements.

1. Fill in all available data with tolerance in metric units.
2. If a specification is not on the template, add the applicable dimensions and tolerances desired.
3. If a specification is not required but is on the template, draw a line through it, and mark the item description with N/A.
4. Include additional notes to the template to aid in quoting and manufacturing.

For questions or help in selecting the best solution for your application requirements, please complete the application data sheet on page 47 and fax it to (216) 271-7020 or email to sales@nookind.com.

Nook Industries, Inc. • 4950 East 49th Street, Cleveland, Ohio 44125-1016

UNIT CONVERSION

ENGLISH TO METRIC		METRIC TO ENGLISH	
<p>Length</p> <p>1 ft = 304.8 mm 1 ft = .3048 m 1 ft = .0003048 km 1 in = 25400 m 1 in = 25.4 mm 1 in = .0254 m 1 in = .0000254 km</p>	<p>Torque</p> <p>1 lb-ft = .001356 kN·m 1 lb-ft = 1.356 N·m 1 lb-ft = 135.6 N·cm 1 lb-ft = 1356 N·mm 1 lb-ft = .1383 kgf-m 1 lb-in = .000113 k-m 1 lb-in = .113 N·m 1 lb-in = .01152 kgf-m</p>	<p>Length</p> <p>1 mm = .00328 ft 1 m = 3.28 ft 1 km = 3821 ft 1 m = .0000394 in 1 mm = .03937 in 1 m = 39.37 in 1 km = 39370 in</p>	<p>Torque</p> <p>1 kN·m = 737.3 lb-ft 1 N·m = .737 lb-ft 1 N·cm = .00737 lb-ft 1 N·mm = .000737 lb-ft 1 kgf-m = 7.23 lb-ft 1 kN·m = 8847.2 lb-in 1 N·m = 8.847 in-ft 1 kgf-m = 86.8 lb-in</p>
<p>Weight/Force</p> <p>1 lb = .454 kg 1 lb = .454 kgf 1 lb = 4.45 N 1 lb = .00445 kN</p>	<p>Rail Weight</p> <p>1 lb/in = 17.9 kg/m 1 lb/ft = 1.49 kg/m</p>	<p>Weight/Force</p> <p>1 kg = 2.205 lb 1 kgf = 2.205 lb 1 N = .225 lb 1 kN = 224.8 lb</p>	<p>Rail Weight</p> <p>1 kg/m = .056 lb/in 1 kg/m = .672 lb/ft</p>
<p>Speed</p> <p>1 ft/sec = .3048 m/sec 1 in/sec = .0254 m/sec</p>		<p>Speed</p> <p>1 m/sec = 3.28 ft/sec 1 m/sec = 39.37 in/sec</p>	



Also find us at:

