



Macron Dynamics, Inc.

## **BELT DRIVEN ACTUATOR BASICS**

**USER GUIDE**

**MAINTENANCE MANUAL**



# Introduction

## **Guarantee Statement Of Assurance**

Thank you for purchasing another quality product from Macron Dynamics, Inc. Every effort has been taken to assure this product was manufactured to the highest industry standards of quality, precision and performance. Macron Dynamics products are subject to a 1 year (from date of shipment) limited warranty for defects in material and workmanship.

## **Guarantee**

Unless otherwise stated herein, Seller will repair or replace, without charge, f.o.b. shipping point, any parts proven to Seller's satisfaction and upon Seller's examination to have been defective in material or workmanship when furnished to the original purchaser. Product must be used in an automation system engineered or approved by Seller. In addition, deterioration or wear caused by abuse, maintenance neglect, severe eccentric loading, overloading, chemical or abrasive action, or excessive heat shall not constitute defects.

Equipment and accessories not of the Seller's manufacture are warranted only to the extent that they are warranted by the manufacturers, and this warranty is applicable only if the defect was the result of normal use, application and service, and is void if the product or any part hereof was tampered with, repaired or altered by any person other than the factory or authorized repair station.

THERE ARE NO OTHER WARRANTIES, EXPRESS OR IMPLIED, INCLUDING THAT OF MERCHANTABILITY AND OF FITNESS FOR A PARTICULAR USE.

Under no circumstances shall seller be liable for any loss of profit or for special, consequential or exemplary damages over and apart from the repair or replacement of Seller's part.

The laws of the State of Pennsylvania shall govern this warranty and any controversy or claim arising from it or its interpretation.

Any controversy or claim arising out of or relating to this warranty, its interpretation, or any breach thereof, which cannot be amicably resolved between Seller and the original purchaser with sixty (60) days of written notice by the aggrieved party to the other, shall be finally settled by binding arbitration submitted to the three (3) arbitrators selected from the panels of the arbitrators of the American Arbitration Association in accordance with the rules and regulations of the American Arbitration Association sitting in Philadelphia, Pennsylvania, with each party to pay its own cost. Authorization for return must be received from Macron Dynamics Inc., before returning any equipment for inspection or warranty repair.

## **Warning**

Macron Dynamics actuators are intended for industrial use only and should not be used to lift, support, or otherwise transport human cargo, unless you have a written statement from Macron Dynamics, Inc. that the actuator unit as used in your application is suitable for lifting human cargo.

## Why Belt driven Actuators

- Length
- Speed
- Acceleration
- Reliability
- Repeatability
- Quiet
- Capacity
- Timing



## Elements of a Belt driven Actuator

- The **Drive** system
  - A belt / a pulley / a tensioning system
  - Provides repeatability
- Structural** beam member
  - Aluminum extrusion provides length flexibility and strength
- Guidance** system
  - Provides accuracy of position and location
- The **Cart**
  - Coupled with the guidance system provides load carrying support
  - Styles
    - Rail & track rollers (angular contact bearings)
    - Plastic rollers w/ needle bearings
    - Profile rail w/ re-circulating ball slide
    - Solid plastic block / extrusion profile matched economy glide
- Motor & **Gearbox** – end user provided

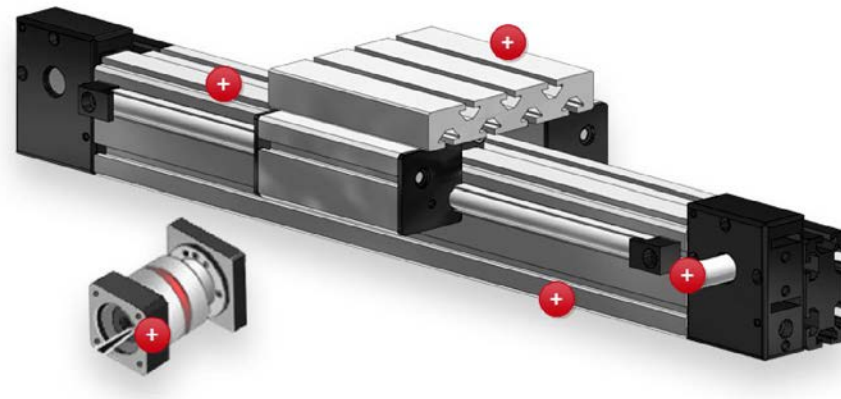

## Product Identification label

Each product has an identification label for recording the part number, serial number and date of manufacture.

- **P/N** [part numbers] are a string of letters and numbers that identify your product. The first 3 letters indicate the family of product. The next 3 letters or numbers indicate the type of actuator or system. The balance of letters and numbers are unique identifiers for your product construction. This part number is important for requesting any information or technical support for your product.
- **S/N** [serial number] is a unique number for traceability of materials and manufacturing history information.
- **Date** – year and week of shipment.
- **Major family reference ID**
  - **MSA** – MacSTANDARD single axis systems
  - **MDS** – Dual systems aka. X/X'
  - **MGS** – Linear Robot 2 & 3 axis Gantry systems
  - **MCS** – Linear Robot 3 axis Cartesian systems



## Product Cautionary notes!

- Macron products may ship as factory assembled modules that require further field assembly. Please follow all assembly instructions provided using hardware and fasteners specified by Macron.
- Motor assembly to Actuator and Gantry systems require care to ensure proper alignment. Follow Macron gearbox or motor mount instructions along with Motor manufacturer guidelines. Torque all hardware according to specifications.
- If T-slot sensors are used for limits of travel and or homing functions, test the operation and switching function prior to full scale power up. Adjust sensor flag gap settings if required.
- During initial start up and operation of the motor drive system, adjust motor torque limits and system speeds to low levels until entire system has been adjusted and de-bugged. Many motors and drive systems can deliver performance that may exceed the capacity of the Macron actuators and damage can result.
- Belt tension is the most important consideration for proper actuator performance and long life. Macron actuator belt tension is preset at the factory prior to shipment [nominal room temperature]. This belt tension may change during shipment or long duration shelf storage due to temperature changes. In addition, belt tension may change after a system inadvertent crash. Please see MQD-TD-01-01 *Belt tensioning tool & tensioning process* for guidance.
- Long travel actuators and gantry systems require support structure under the lowest axis [typically called the X axis] to prevent deflection and ensure system repeatability.
- Only use Macron replacement part kits for actuator and gantry system maintenance and repair. Our components are unique and have been designed to meet our demanding product performance requirements.
- Machines and motor drive systems must be properly grounded to prevent ED [Electrical Discharge] induced damage to Actuator bearings.

## Preventive Maintenance

Macron actuator and gantry systems require a few simple maintenance procedures to prolong the system life and operation.

- **Belt tension monitoring and tension setting**

Reference process- MQD-TD-01-01

- **Lubrication of linear rails & bearings**

Reference process- MQD-TD-03-00

- **Cart adjustment & pre-loading**

Reference process- MQD-TD-05-00

- **Replacement parts kits**

See specific Actuator & Gantry system detail guide sections for suggested parts, proper part numbers and replacement instructions.

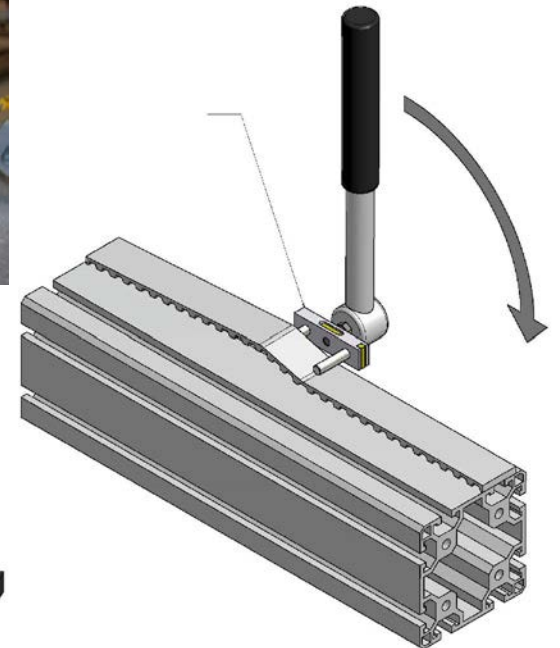
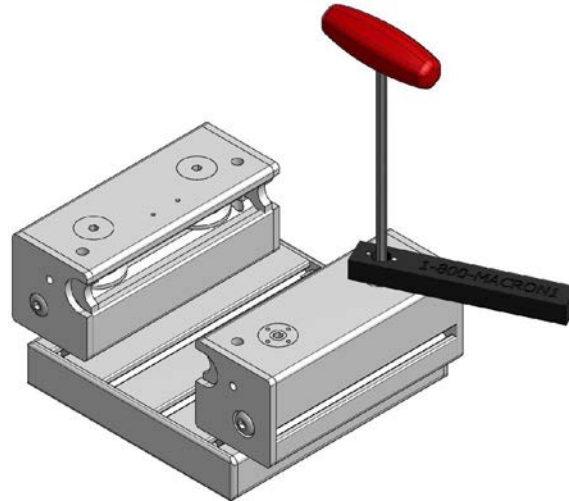

## Belt tension

Belt tension is the most critical element of the performance of Macron belt driven Actuators and Linear Robot gantry systems. Proper belt tension ensures that the tooth of the belt and tooth of the pulley mesh smoothly for precise repeatability and near zero backlash performance.

Macron has developed a novel approach to measuring and setting the belt tension using a special tool with precision spaced rods with bubble level indicator and a standard commercial torque wrench [20 – 250 in-lb. range]. Please reference technical document MQD-01-01 for detailed instruction. Macron has determined a specific torque setting for each belt width and travel distance. When the tool is positioned on the belt and the torque wrench is set and turned at the recommended in-lb. setting, proper tension is achieved when the bubble level is centered and the torque wrench releases. Standard tolerance on the torque wrench setting is +/- 5 lbs.

Belt tension should be checked at the following frequency-

- At initial assembly and integration of the Actuator or Linear Robot
- After 24-48 hours of duty cycle running.
- At any time the Macron logo on the belt shows signs of smearing or erasure.
- After any system crash such as exceeding travel limits and striking hard stops or equivalent improper use of the system.
- PM frequency
  - Normal temperatures – every 3 months
  - Wide temperature variation applications - monthly

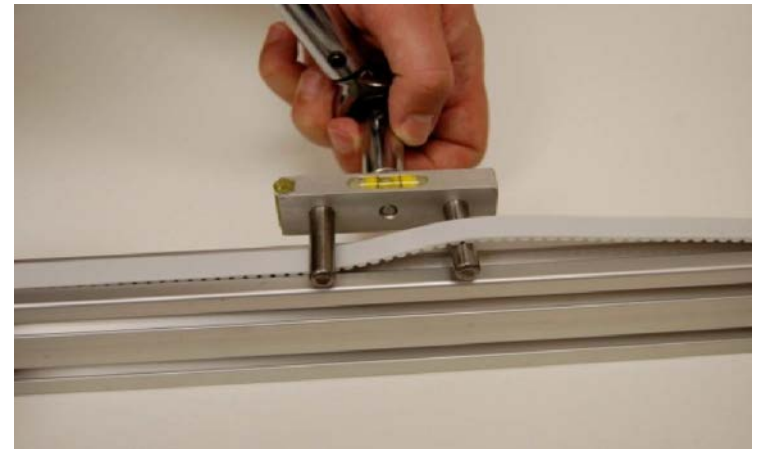



## Lubrication

The pulley assemblies, both drive and idler do not require lubrication. The radial bearings used in these assemblies are permanently lubricated and sealed. Disassembly of these pulley assemblies will result in permanent damage to the component parts and is not recommended.

The guidance systems do require lubrication to prevent wear and prolong the life of the components. There are multiple styles of guidance used in Macron Actuators and Linear Robots. Each requires a different lubricant and application frequency.

### Styles:

- **Round rail guides with track rollers mounted to Carts-**
  - track roller bearings are permanently lubricated and sealed.
  - Round rails are hard chrome plated. Due to the possibility of Tribocorrosion, a film of lightweight oil is recommended. The carts are designed with an integrated felt wiper to absorb and apply this oil while constantly cleaning the rail. Add 10 drops of oil to each wiper felt on a monthly basis for PM. We suggest the wipers are changed every 6 months in normal environments [3 months in dirty environments].
- **Profile rail with linear bearing blocks-**
  - Bearing blocks require lubrication by injecting grease into the fitting on the end of each block. The grease is a commercially available item. Please see Macron MQD-TD-03-00 for formula to determine lubrication frequency based on application duty cycle and the proper lubricant required.
- **Plastic roller carts-**
  - Polymer tires ride inside the aluminum extrusion profile. The radial needle bearings are permanently greased and re-lubrication is not recommended.

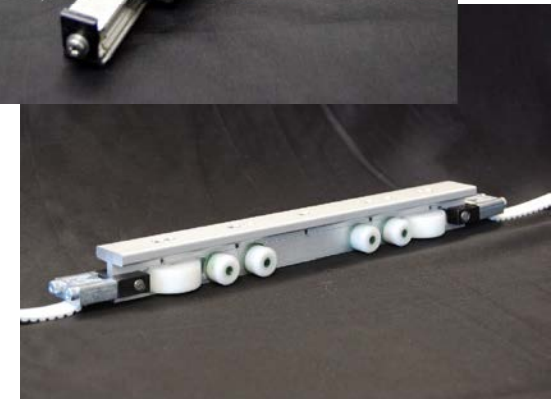
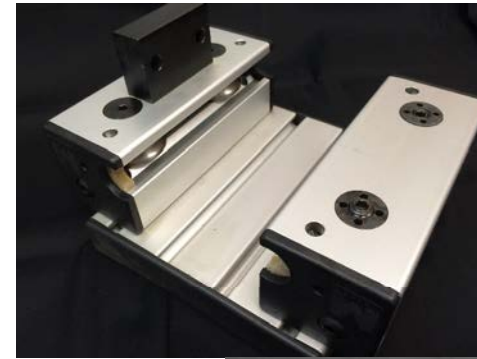

## Cart adjustment & preloading

The Cart systems on Macron Actuators and Linear Robot gantry systems are factory set for smooth motion and to ensure uniform repeatability. There are multiple cart styles across the Macron product line. Each style will require a different method of adjustment. Carts rarely require adjustment by a user. In applications of high shock loading, excessive vibration, or environments with abrasive dusting, play may develop between tracking rollers and the guide rails. This play may be corrected by adjusting the pre-load of the cart. Cart adjustment and preloading is required for any cart replacement. Reference Macron document MQD-TD-05-00 for guidance. This document may be found in the appendix of this guide.

### Styles:

- **Round rail guides with track rollers mounted to Carts-**
  - There are 4 or more track rollers on a cart assembly. One side of the cart has fixed roller positions. The opposite roller has an eccentric axle which when rotated will change the position of the roller relative to the rail.
- **Profile rail with linear bearing blocks-**
  - No cart adjustment is required for the life of the linear bearing blocks.
- **Plastic roller carts-**
  - Polymer tires ride inside the aluminum extrusion profile. Cart pitch and yaw are pre-set and rarely require adjustment except after a cart replacement.

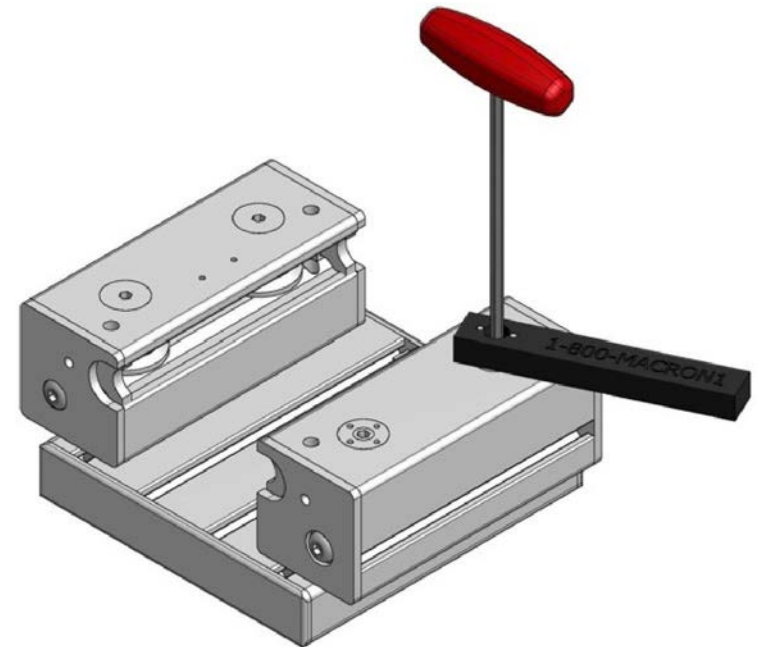

## Replacement Parts kits

Replacement part kits are available for field servicing all Macron Actuators and Linear Robot gantry systems. The Macron website Resources tab [www.macrondynamics.com](http://www.macrondynamics.com)

### Kits:

- **Drive & Idler pulley assemblies**
  - Pre-assembled to ensure perfect fit. Provide the Actuator or Gantry system part number to assure the right match.
- **Belt kits**
  - Include belt at nominal length for precise field fitting and cutting to length and new tension assemblies and hardware. Measure the overall length of the Actuator to determine the right size kit.
- **Cart replacement modules**
  - Pre-assembled for fast repair. We suggest replacing the belt with any cart replacement for the most effective preventive maintenance approach.
- **Wiper kits**
  - Dry and dirty lubricating felt pads degrade the life of the guidance system. Plastic caps and hardware prevent damaging screw threads during replacement. This kit should be replaced every quarter in a good PM program.

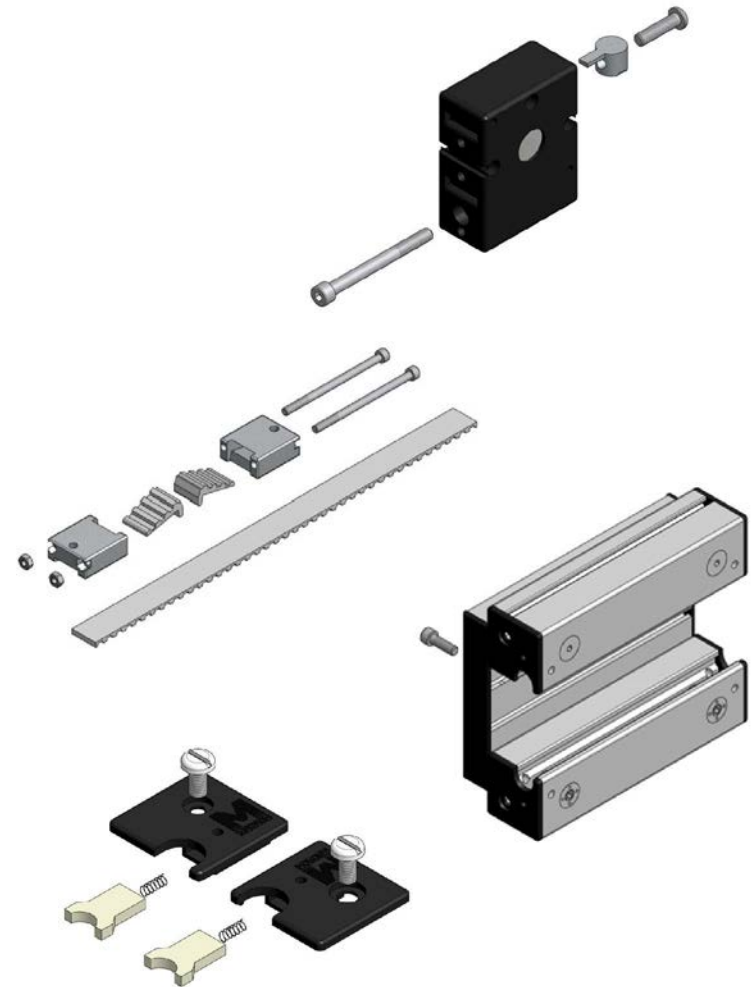



## Product Documentation

- Datasheet packets are available for each product on the Macron website:
  - [www.macrondynamics.com/resources](http://www.macrondynamics.com/resources)
  - Datasheets detail the replacement parts associated to specific products and include image of the parts kit with material listing.
  - Installation instructions
- Product Technical documents- are included in this document
  - MQD-TD-01-01 Belt tensioning tool & tensioning process
  - MQD-TD-06-01 Product Lubrication guide – Round rail / Track roller guidance systems
  - MQD-TD-07-00 Product Lubrication guide – Linear bearings / Profile rail guidance systems
  - MQD-TD-11-00 Cart adjustment & pre-loading
  - MQD-TD-10-00 Macron MPG Gearbox installation instructions



### Macron Belt Tension tool & tensioning process

#### TENSION TOOL

PART NO.

#399 - 25 (For 12 & 25mm)

#399 - 50 (For 50mm)

DESCRIPTION

Used in conjunction with Pound Inch Torque Wrench

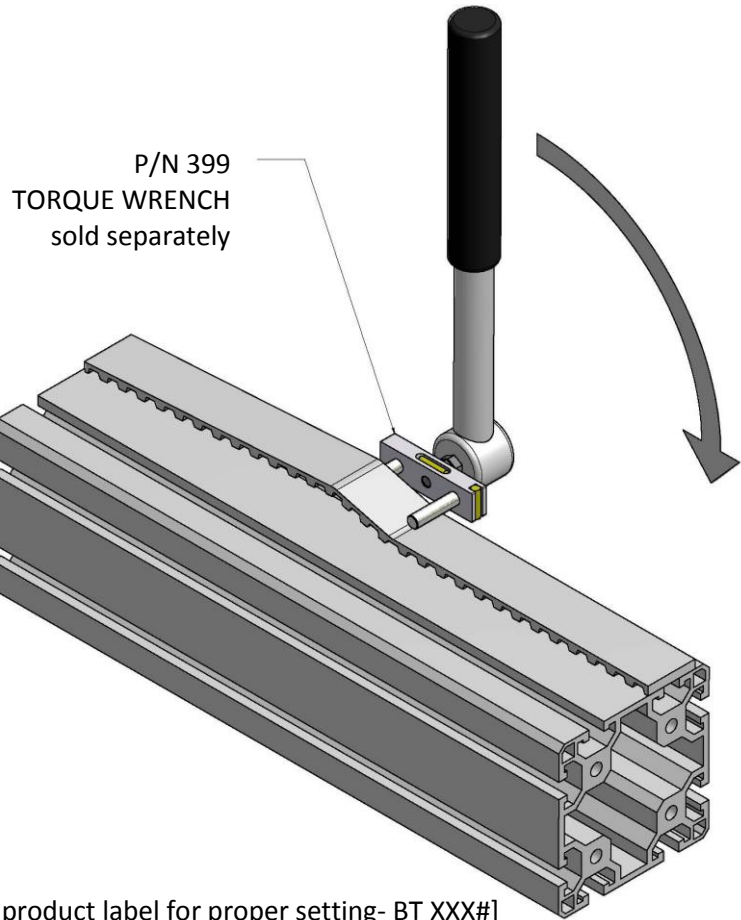

#### TORQUE WRENCH

PART NO.

#397 [25 - 250 lbs-in]

#### Tension adjustment Procedure

1. SET TORQUE WRENCH TO SPECIFIED LBS.-IN. [see product label for proper setting- BT XXX#]
2. SLIDE CART &/OR TENSION ASSEMBLY TO ACTUATOR END FARTHEST FROM MOTOR.
3. PLACE TENSION TOOL IN CENTER OF BELT SPAN.
4. TURN WRENCH IN THE DIRECTION SHOWN WHILE OBSERVING TENSION TOOL BUBBLE LEVEL.
5. LEVEL BUBBLE SHOULD BE BETWEEN THE LINES WHEN TORQUE WRENCH RELEASES AT SPECIFIED LBS.-IN.
6. IF BUBBLE IS NOT BETWEEN THE LINES, ADJUST BELT TENSIONER SCREWS UNTIL TOOL READS LEVEL.
7. REPEAT STEPS 1-5 TO CHECK ACCURACY.

\*NOTE: If Actuator is not mounted in a horizontal or vertical plane. Disregard the bubble and ensure the tension tool body is parallel to the actuator extruded beam.

<b>MACRON DYNAMICS, INC.</b>		<b>1-800-622-7661</b>	
S/N	15936	DATE	1344
P/N	MSAR20B000013718	REV.	BT 100*

Tension setting = 100 lb-in in this example



### Product lubrication guide: Round rail / Track roller guidance systems

Macron MSA-14S, MSA-14H, MSA-628 & MSA-M6S actuators have lubricating end caps. These lubricating end caps are located on the ends of the movable carts. Located inside these end caps are felt wipers. These felt wipers help to remove small pieces of debris from the rail, as well as administering a lubricating oil onto the rail surface to protect against corrosion. The felt wipers will require re-lubrication. The lubrication interval is dependent on the duty cycle of the specific application. The wipers can be re-lubricated by applying oil to the absorbent felt. It is recommended that a 5 or 10 weight machine or mineral oil be used for lubrication. Macron suggests applying 5-10 drops of oil to the wipers on a monthly basis.

If the end caps become damaged or cracked, replacement Wiper Kits should be used. Macron suggests replacing all lubricating end caps on a 6-month cycle to ensure trouble-free use and extend the actuator life. In applications with dirty or dusty environments, this frequency should be increased.

Photos below show each actuator type with the lubricating felt location. This process should also be followed for all Linear Robot products designated MGS-UCx & MCS-xxx with round rails and track roller guidance.

#### MSA-14S



Lubricating end caps



Oil application port



### MSA-628 & MSA-M6S

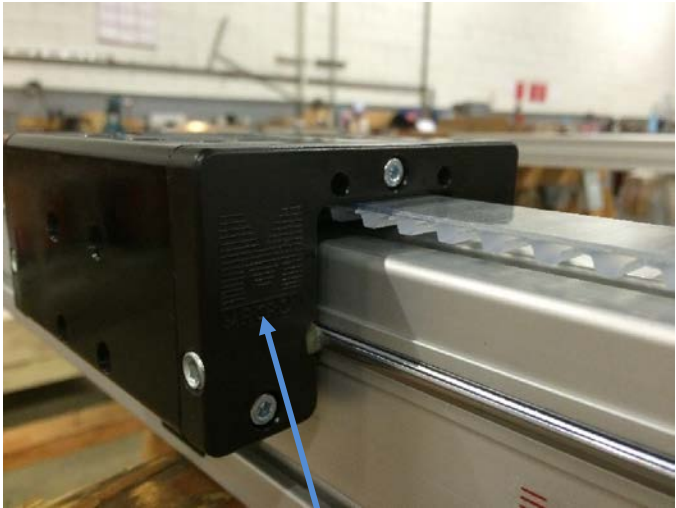

Lubricating end caps

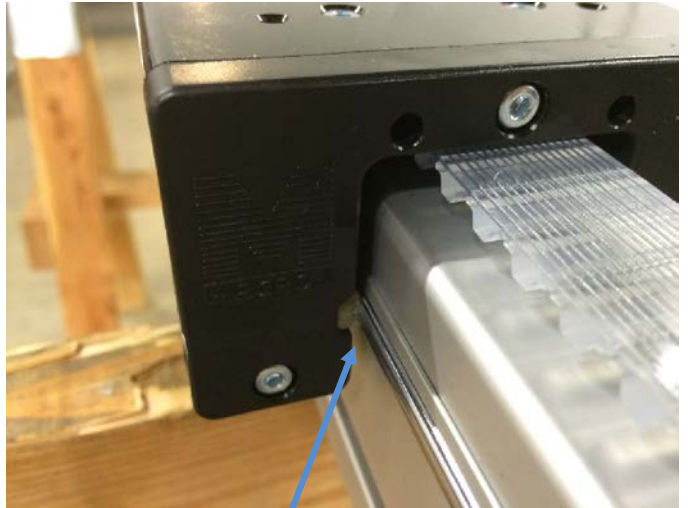

Oil application point

### MSA-14H

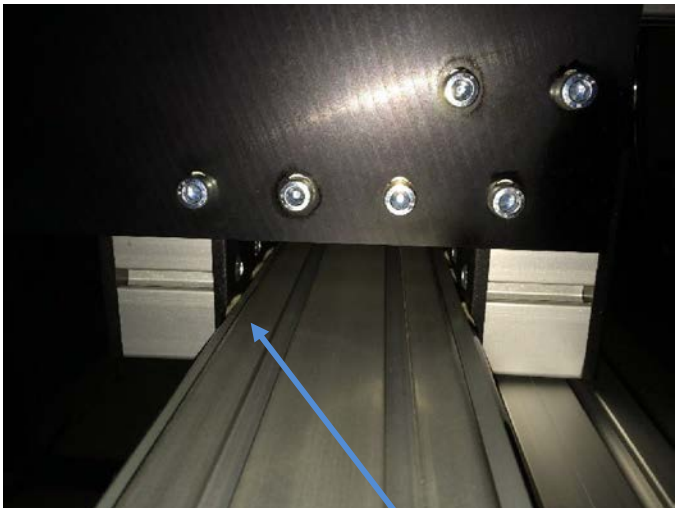

Lubricating felt wipe



Oil application point



### Product lubrication guide: Linear bearing / Profile rail guidance systems

Macron MSA-R15, MSA-R6S, & MSA-R20 actuators have linear bearing blocks and profile rail guidance systems. The linear bearing blocks used on Macron Dynamics products have “lip seals” and are pre-lubricated prior to shipment. Depending on the application environment the linear bearings will require lubrication on a preventive maintenance cycle. The lubrication cycle is dependent on the application duty cycle and operating environment and a formula is used to determine when lubrication should be performed. The user is responsible for this calculation based on the guidelines at the end of this product bulletin.

The runner block bearings have a low profile grease fitting installed on one end of the block. The opposite side is plug sealed. On both single and dual bearing block actuators, the grease fitting will be accessible from the end of the cart.

We recommend a combination of standard grease gun parts that will produce a set-up that will allow all grease fittings to be lubricated (photo below). All of these components are available through McMaster-Carr or Macron. The recommended grease is Mobil SHC220 NLGI2 a super-premium quality synthetic lubricant. This lubricant is commercially available from many industrial supply outlets [Macron does not sell or supply grease].

This process should also be followed for all Linear Robot products designated MGS-Rxx & MCS-Rxx with linear bearing / profile rail guidance systems.

#### Linear bearing block

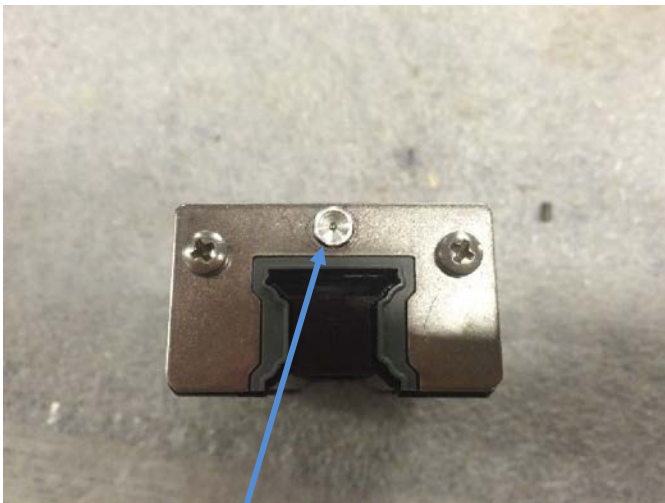

Low profile grease fitting

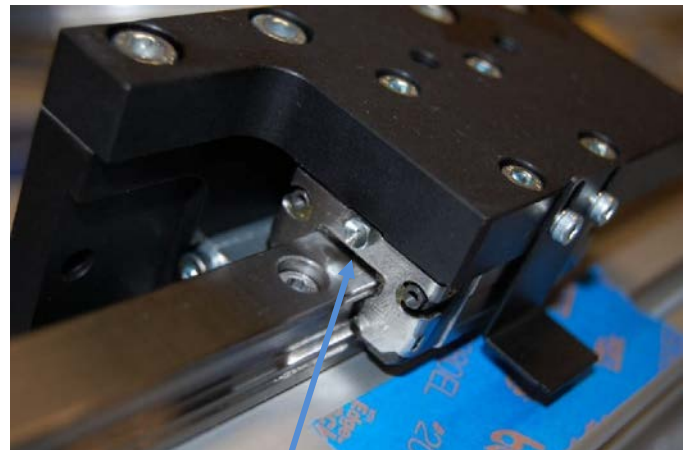

Cart assembly, fitting access





### Suggested grease application gun set-up



Direct purchase of parts: McMaster Carr

- Compact grease gun- p/n 10225K95
- Coupler extension- p/n 2906K92
- Polypro hose with coupler- 1195K52

### Caution:

***Macron Dynamics, Inc. cannot know all of the application environments or uses of our Linear Motion products by our Customers and end users. It is the responsibility of the end user to determine the proper PM [preventive maintenance] required.***

Lubrication frequency is based on distance traveled and the duty cycle of the actuator.

- Lubrication is required at the 4,000 km travel increment for 20 and 15 series linear bearings in standard loading condition.
- example: duty cycle 60 cycles per minute, 24 hours a day at 7 days per week, travel 1.6 meters
  - 24 hours x 60 min = 1440 min/day x 60 cycles = 86,400 cycles per day x 1.6 meters = 138,240 meters traveled per day or 138 km
  - 4,000 km / 138 km/day = 29 days or approximately once per month a lubrication interval should be scheduled.



### Cart Installation & pre-load adjustment process-

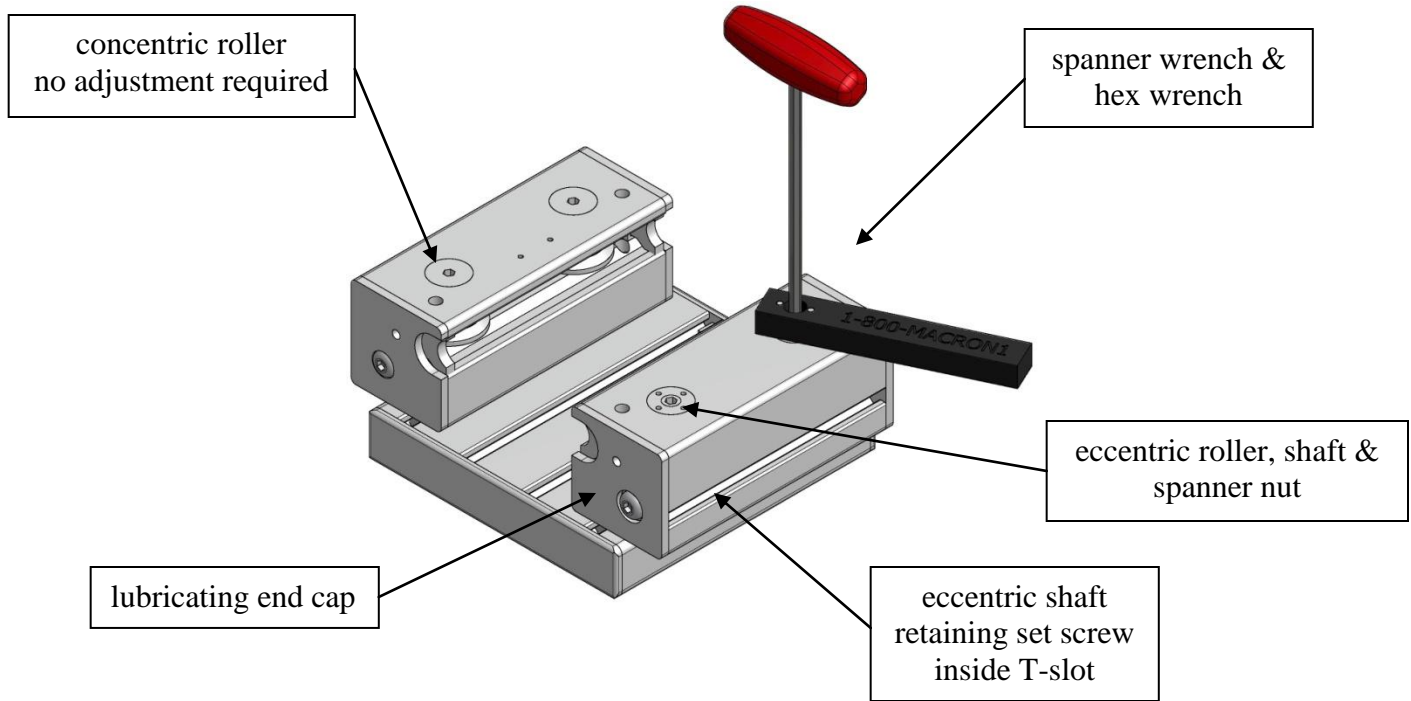

- Remove lubricating end caps from replacement cart to simplify installation
- Slide cart onto actuator ensuring track rollers align with round rail- [note: carts may have 4 or more roller sets]
- Loosen the eccentric shaft retaining set screws visible inside the T-slot
- Using spanner wrench & hex wrench - slightly loosen spanner nuts on all eccentric side rollers
- Pre-load adjustment- using hex wrench rotate eccentric shaft until roller contacts the rail and does not slip - do not overload - holding hex wrench steady, tighten the spanner nut with spanner wrench until snug.
- Repeat for all eccentric rollers
- Slide cart back and forth along rail - there should be no play in any plane. Observe rollers for rotation. Cart should not bind. Re-adjust as required.
- Tighten eccentric retaining set screws
- Replace lubricating end cap
- Connect belt tension assembly to the cart

**Caution: do not over pre-load the cart. This process is intended to ensure roller contact with the guide rails to allow for component and assembly tolerance variation. Overloading causes excess wear on bearings and drive system.**



**MACRON DYNAMICS, INC.**

**PRODUCT  
Datasheet**

**DESCRIPTION**

**Spanner Wrench  
P/N-055**

The Macron Spanner Wrench is used to tighten the Spanner Nut on a Macron 14 Cart. The Spanner Nut locks the Eccentric Shaft in place after appropriate Macron 14 Roller adjustment has been reached.

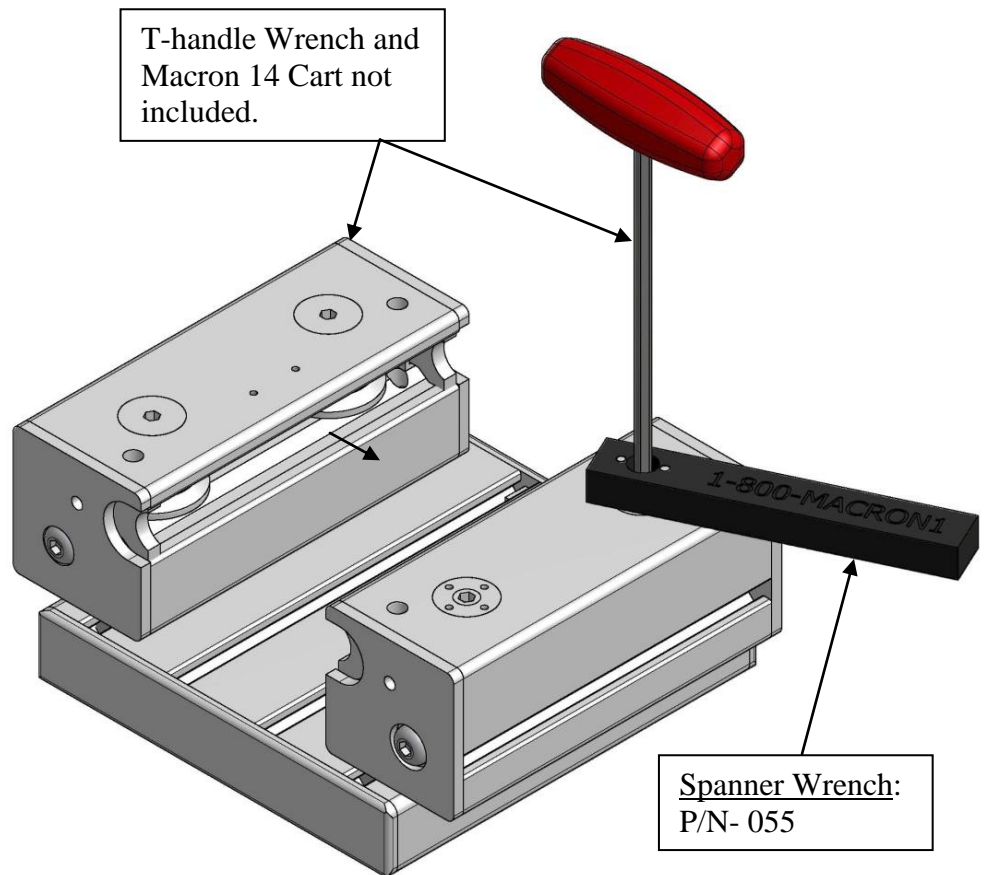

**MACRON DYNAMICS, INC.**  
100 Phyllis Drive  
Croydon, PA 19021  
MQD-TD-11-00

P: 215-443-8888  
F: 215-443-0981  
macron@macrondynamics.com

[www.macrondynamics.com](http://www.macrondynamics.com)



# Macron MPG Gear box - Installation and Assembly Instructions



**Step 1:**  
Rotate input clamping elements until the bolts are visible through the access holes on both the input and output.



**Step 2:**  
Ensure all mounting surfaces are clean. With the motor and gearbox VERTICAL, insert the motor into the gearbox.

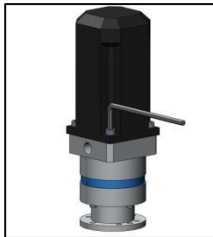

**Step 3:**  
Using the 4 bolts provided, tighten the motor to the gearbox adapter. Fully tighten the bolts as noted in [Table 1](#).



**Step 4:**  
Tighten the clamping element onto the motor shaft as noted in [Table 2](#). Finally, insert the provided plug into the access hole.



**Step 5:**  
Ensure all mounting surfaces are clean. Using the 4 bolts provided, tighten the slide adapter to the slide. Fully tighten the bolts as noted in [Table 1](#).



**Step 6:**  
Ensure all mounting surfaces are clean. With the slide and gearbox VERTICAL, insert the gearbox onto the slide. Using the 4 bolts provided, tighten the gearbox to the slide. Fully tighten the bolts as noted in [Table 1](#).



**Final Step:**  
Tighten the four screws on the output clamping element onto the slide shaft in a star pattern as noted in [Table 3](#). Finally, insert the provided plugs into the access holes.

Table 1		
Bolt Size	Hex Size	Torque (in-lbs)
M4	3mm	40
M5	4mm	80
M6	5mm	130
M8	6mm	320
M10	8mm	640
M12	10mm	1100

Table 2		
Macron Part Number	Input Clamping Torque (in-lbs)	Output Clamping Torque (in-lbs)
MPG-062	53	124
MPG-084	80	266
MPG-118	177	354

Table 3	
First Round Torque	MPG-062 = 62 in-lbs MPG-084 = 133 in-lbs MPG-118 = 221 in-lbs
*Second Round Torque	MPG-062 = 124 in-lbs MPG-084 = 266 in-lbs MPG-118 = 354 in-lbs

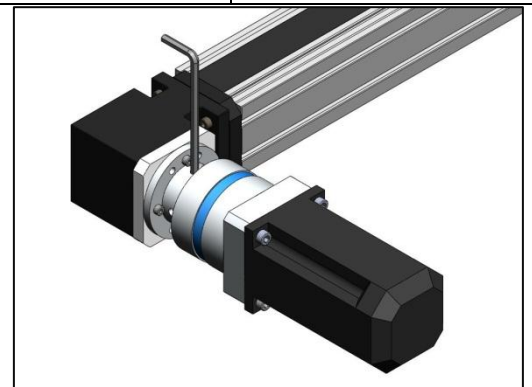

*\*Repeat Second Round Torque stage until torque value listed is confirmed at each bolt.*