

Value Added Services

- Ball Screw Repair Services
- Plating/Coating services
- Corrosion resistant TDC
- Machined per print
- Custom engineered solutions provided by in house engineering department

Don't have a print? No problem!

Send us your ball screw and we will reverse engineer and create a CAD file for your use!

24 hour turnaround for Breakdown services available

Call (919) 863-0837

3D Modeled Reverse Engineered Ball Screw Services



Precision Ball Screw Quality Assurance



Miniature ball screw series

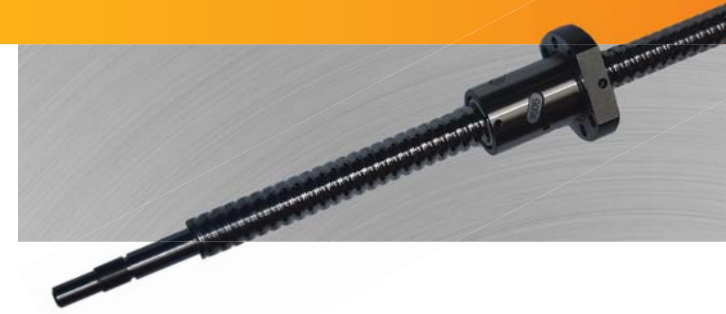

BALL & LEAD SCREW ASSEMBLIES

- Precision Ground Ball Screws
- Rolled Ball Screws
- Lead Screws "NEW"

Interchangeable with **Hayden Kerk** and **Thomson BSA**

- ✓ Fast Lead times!
- ✓ Machined per print!
- ✓ Custom Specifications!
- ✓ Ball Screw Repair Services!

Accu Tech USA
First in Motion Solutions

Customer Service: (919) 863-0837

Fax: (919) 863-3742

www.accu-techusa.com

RFQ: quote@accu-techusa.com

12339 Wake Union Church Rd., STE 110
Wake Forest, NC 27587

Accu Tech USA
First in Motion Solutions

PRECISION ROLLED BALL SCREWS

Size Range

(6mm DIA up to 100m DIA)

Leads offered

(1mm up to 50 mm)

- C5, C7, C10 Accuracy Classes
- Multiple thread starts available
- End machining to print
- High Speed/High lead (25x25, 25x50)
- Preloaded anti-backlash oversized ball design
- Gothic Arch Design

PRECISION GROUND BALL SCREWS

Size Range

(6mm DIA up to 100m DIA)

Leads offered

(1mm up to 50 mm)

- C0 - C5 Accuracy
- Multiple thread starts available
- End machining to print
- High Speed/High lead
- Miniature ball screws
- Preloaded anti-backlash
- Gothic Arch Design
- Double Nut Preload With Precision Spacer

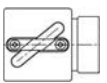
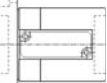
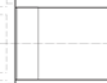
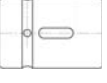
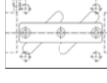
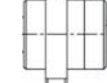
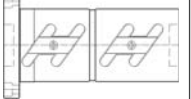
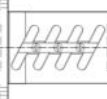
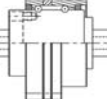

BALL SCREW NUT TYPES

 V Thread	 Flanged	 69051 DIN Spec
 Cylindrical	 Flush Mount	 End Return
 Double Nut	 Custom	 Rotating Nut



LEAD & ACME SCREWS with specialized nuts

Interchangeable with **Hayden Kerk** and **Thomson BSA**

- Spring loaded anti-backlash nut
- POM/Acetal nuts
- Brass nut
- Geared nut
- Custom designs possible for OEM specific applications
- Stainless Steel Screw Shaft
- PTFE Coating
- End Machined Per Print
- Metric & English Leads



BALL SCREW END SUPPORTS, MOTOR MOUNT BLOCKS, & NUT HOUSINGS

- Easy to install
- Why design your own parts when you can get your parts **"READY TO SHIP"!**
- Full size offering!
- Interface to **ANY** motor make

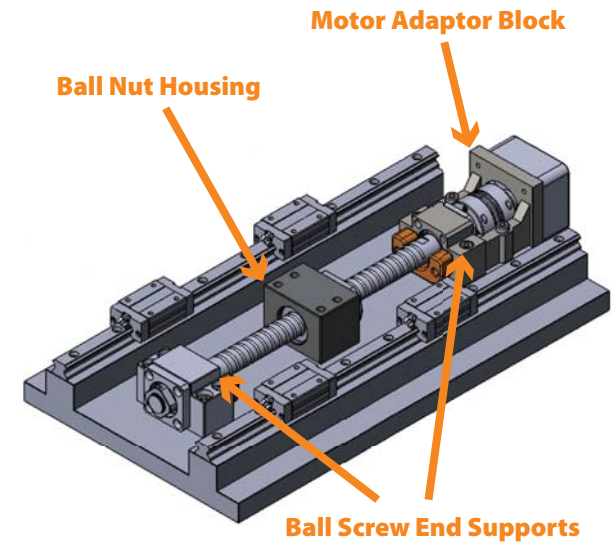

Accu Tech USA
First in Motion Solutions